

# Operator Manual

For printer model:

# S84NX

# S86NX

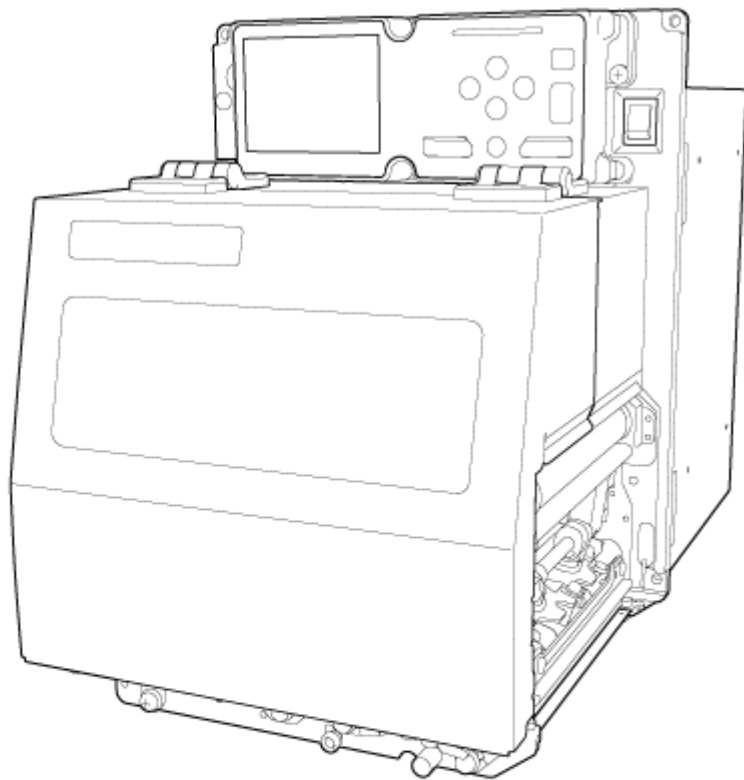

---

# Table of Contents

---

<b>Before You Start.....</b>	<b>8</b>
About This Manual.....	8
Safety Precautions.....	9
Copyrights.....	14
Trademarks.....	15
<b>What You Can Do with This Product.....</b>	<b>16</b>
Features of the Product.....	16
Various Ways to Output.....	17
Outputting with General-purpose Software.....	17
Outputting and Controlling with Dedicated Command.....	18
Controlling the Product with External Signal.....	19
Outputting with Standalone (AEP) Applications.....	20
Outputting with Simple Standalone Application.....	21
<b>Basic Information.....</b>	<b>26</b>
Bundled Accessories.....	26
Optional Devices.....	27
Product Orientation.....	28
Parts Identification.....	29
Parts Identification for the Product.....	29
Parts Identification for the Operator Panel.....	33
Using the Operator Panel.....	35
LED Indicator.....	35
Operations in Online/Offline Mode.....	36
Status Icon.....	39
Operations When Errors Occur.....	45
Adjusting the Print Settings During Printing.....	46
Canceling the Print Job.....	47
Guidance Videos.....	49
List of the Guidance Videos.....	50
Playing the Guidance Video from the Error Screen.....	51
Getting Access to the Guidance Video in Online Mode.....	52
Operating the Guidance Video.....	55
Settings Mode.....	56
Settings Mode Menus.....	57
Changing to the Settings Mode.....	58
Logging In to/Logging Out of the Settings Mode.....	60
Item Selection.....	61
Setting Value Input or Selection.....	63
Customizing the [Shortcut] Menu.....	66
Registering Items to the [Shortcut] Menu.....	66
Unregistering Items from the [Shortcut] Menu.....	67
Product Memory and USB Memory.....	69
<b>Getting Started.....</b>	<b>70</b>
Installation.....	70
Installation Space.....	71

Front View.....	71
Rear View.....	71
Media Dispensed View.....	72
Top View.....	73
Installing the Product onto a Support Structure/Applicator.....	76
Powering On/Off the Product.....	77
Connecting the Power Cord.....	77
Powering On the Product.....	78
Powering Off the Product.....	80
Initial Setup (Startup Guide).....	82
Startup Guide Flow.....	83
Startup Guide Cancelation.....	88
Manually Setting the Print Mode.....	89
Connecting the Product to a Computer.....	92
Procedure for Connecting the Product to a Computer.....	93
Connecting Interfaces.....	94
Available Interfaces.....	94
USB Interface Connection (Standard).....	95
LAN Interface Connection (Standard).....	96
NFC Interface Connection (Standard).....	96
RS-232C Interface Connection (Standard).....	97
Wireless LAN Interface Connection (Optional).....	98
Configuring the Interface Settings.....	100
Interface Setting Methods.....	100
Configuring the Interface Settings from the Interface Menu of the Product.....	100
Configuring the Interface Settings Using the All-In-One Tool.....	102
Installing the Printer Driver.....	104
All-In-One Tool Features.....	105
<b>Loading Media and Ribbon.....</b>	<b>106</b>
Media, Ribbon and Print Methods.....	106
Loading Media.....	107
Usable Media.....	107
Adjusting the Position of the Media Sensor.....	108
Winding Direction of the Media.....	109
Precautions for Loading the Media.....	110
Loading Media with Dispenser.....	111
Loading Media without Using Dispenser.....	117
Loading Ribbon (Thermal Transfer Only).....	121
Checking the Ink Side of the Ribbon.....	122
Loading the Ribbon.....	124
Replacing the Ribbon.....	129
Settings to Match the Media.....	134
Print Method (Combined Direct Thermal/Thermal Transfer Model Only).....	134
Media Sensor Type.....	137
When to Replace Media and Ribbon.....	140
Checking the Remaining Amount of Media and Ribbon.....	140
Conditions That Trigger Paper End.....	141
Conditions That Trigger Label Near End.....	146
Conditions That Trigger Ribbon End (Thermal Transfer Only).....	147
Conditions That Trigger Ribbon Near End (Thermal Transfer Only).....	148
<b>Various Settings of the Product.....</b>	<b>149</b>
The Product's [Settings] Menu.....	149
[Shortcut] Menu.....	150
[Printing] Menu.....	151

[Label Length].....	151
[Label Width].....	151
[Auto Measure].....	152
[Printing Mode].....	153
[Ribbon Near End].....	153
[Speed].....	153
[Sensor Type].....	154
[Micro Label Print Mode].....	154
[Print Mode].....	156
[Backfeed].....	157
[Darkness].....	157
[Imaging].....	157
[Advanced].....	160
[Interface] Menu.....	179
[Network].....	179
[RS-232C].....	219
[USB].....	222
[NFC].....	223
[Ignore CR/LF].....	223
[Ignore CAN/DLE].....	223
[External I/O].....	223
[RFID] (S84NX Only).....	228
[Applications] Menu.....	238
[Protocol].....	238
[Auto Switch Group].....	239
[SBPL].....	240
[SZPL].....	246
[S IPL].....	248
[SDPL].....	249
[AEP].....	258
[System] Menu.....	260
[Regional].....	260
[Notifications].....	262
[Sound].....	264
[LCD Brightness].....	265
[LED Indication].....	265
[Cover Open Sensor].....	265
[Show Total Count].....	266
[Password].....	266
[Tools] Menu.....	269
[Test Print].....	269
[HEX-Dump].....	279
[Reset].....	283
[Profiles].....	285
[Service].....	286
[Factory].....	286
[Certificates].....	286
[Barcode Checker].....	287
[Clone].....	293
[Clone Notice Setting].....	293
[Support Info].....	294
[Logging Function].....	295
[Startup Guide].....	296
[Information] Menu.....	297
[Help].....	297
[Build Version].....	298
[Applications].....	299
[Installation Log].....	299
[Print Module].....	299

[FPGA Version].....	300
[Counters].....	300
[IPv4 Address].....	301
[IPv6 Address].....	301
[LAN MAC].....	301
[Wi-Fi MAC].....	301
[Wi-Fi Region].....	301
[Wi-Fi Status].....	302
[Wi-Fi Direct].....	302
[Wi-Fi Versions].....	302
[Wi-Fi Module].....	302
[USB Serial].....	302
Configuring the Product Settings from a Web Browser.....	303
Accessing to the Web Configuration Page.....	303
Dashboard.....	305
Settings.....	307
Tools.....	309
Certificates.....	311

**Adjusting the Product.....312**

Printable Area.....	312
Media Sensor Positions and Media Stop Positions.....	315
Flow of Printing Operations.....	317
Printing Operations.....	317
Operations in Continuous Mode.....	318
Operations in Dispenser Mode.....	326
Operations in Dispense & Print Mode.....	334
Operations in Linerless Mode.....	339
Operations for RFID Write (S84NX Only).....	341
Operations When the Barcode Check Function Is Enabled.....	349
Adjusting the Base Reference Point.....	350
About the Base Reference Point.....	350
Adjusting the Print Position.....	351
Adjusting the Dispenser Stop Position.....	354
Adjusting the Print Quality.....	357
Adjusting the Print Darkness.....	357
Adjusting the Print Speed.....	360
Adjusting the Product's Buzzer Volume.....	363
Adjusting the Head Pressure Balance.....	365
Print Head Balance.....	365
Pressure Balance Setting.....	366
Adjusting the Head Position.....	368
Left - Right Pressure Balance Setting.....	368
Front - Rear Head Alignment.....	371
Adjusting the Ribbon Tension Balance.....	373
RFID Settings (S84NX Only).....	375
Usable RFID Standards.....	375
Configuring the Product to Encode Inlays.....	376
Loading the RFID Tag Model.....	378
Printing RFID Tag Errors.....	381
RFID Printing Tips.....	386
Configuring Optional Barcode Check Function.....	387
Basic Specifications of the Barcode Check Function.....	387
Setting Up the Barcode Checker.....	391
Operational Settings for the Barcode Checker and Installation.....	391
Doing a Test Read with the Barcode Checker.....	391

Enabling the Barcode Check.....	395
Selecting the Barcode Check Mode.....	395
Contents of the Check for Readable Mode and Comparison Mode.....	397
Restrictions for the Barcode Check Function.....	400
Initializing the Product.....	402
Procedures for Initializing.....	402
List of Initial Values.....	406
[Printing] Menu.....	406
[Interface] Menu.....	411
[Applications] Menu.....	424
[System] Menu.....	429
[Tools] Menu.....	430
[Information] Menu.....	434
<b>Maintenance.....</b>	<b>436</b>
Cleaning the Product.....	436
Cleaning.....	436
Cleaning Intervals.....	437
Cleaning Using the Cleaning Kit.....	438
Cleaning Using the Cleaning Sheet.....	446
Replacing Consumable Parts.....	449
Replacing the Print Head.....	449
Replacing the Platen Roller.....	453
Replacing the Pressure Roller.....	457
Replacing the Pressure Plate.....	461
Replacing the Feed Roller.....	465
Replacing the Fan Filter.....	469
Operating the Notification Screen of the SOS (SATO Online Services) On-Demand Mode (SOS users only).....	470
SOS (SATO Online Services) Application (SOS users only).....	472
<b>When You Are in Trouble.....</b>	<b>473</b>
When an Error Message Appears.....	473
Error Message Indication and Operating Procedure When the SOS (SATO Online Services) Is Enabled (SOS users only).....	529
Messages for Provisioning Errors When SOS (SATO Online Services) is Enabled (SOS users only).....	531
Contact Information for When You Are in Trouble.....	533
<b>Product Specifications.....</b>	<b>534</b>
Hardware.....	534
Interface.....	539
Supported Interfaces.....	539
USB Interface.....	540
LAN Interface.....	541
NFC Interface.....	542
RS-232C Interface.....	543
External Signal (EXT) Interface.....	545
Basic Specifications of External Signal (EXT) Interface.....	545
Connector Pin Specifications of External Signal (EXT) Interface.....	545
Timing Chart of the EXT Input/Output Signal.....	551
Wireless LAN Interface.....	552
Printer Languages.....	554
Standards.....	555

Usable Media.....	556
Media Size for Each Print Speed.....	559
Usable Ribbon.....	560
Usable Fonts.....	561
Usable Barcodes.....	585
<b>Support and Warranty.....</b>	<b>587</b>
SOS (SATO Online Services) (SOS users only).....	587
Warranty for Consumables within the Product Warranty Period.....	588

---

# Before You Start

---

## About This Manual





---

Thank you for purchasing the SATO S84NX/S86NX (hereafter referred to as "the product").

This manual supplies basic information on how to operate the product. Read the manual carefully to understand each function of the product before operation.

### Symbols

This operator manual uses following symbols:

Item	Description
 Warning	The Warning symbol indicates that you can cause death or serious injury if you do not follow the instructions or procedures.
 Caution	The Caution symbol indicates that you can cause injury or property damage if you do not follow the instructions or procedures.
 Note	The Note symbol indicates useful and supplemental information that you should know.
 Reference	The Reference symbol indicates the link of relevant information.



- Reproduction in any manner of all or part of this manual is prohibited.
- The content of this manual is subject to change without notice.
- Great care has been taken in the preparation of this document, but if any problems, mistakes, or omission are found, please contact your SATO reseller or technical support.



- The illustrations and screens in this manual are of the S84NX (Standard/Left-hand type), unless otherwise noted.
  - This manual uses the build version 8.1.2-r1 firmware in its descriptions.
-



## Safety Precautions



---

This topic describes how to use the product safely.

Be sure to read the following information carefully before using the product.

### Pictographic Symbols

This operator manual and the product labels use a variety of pictographic symbols. These symbols emphasize the safe and correct use of the product and to prevent injury to others and property damage. The explanation of the symbols is as follows. Be sure to understand these symbols well before you read the main text.

 <b>Warning</b>	Ignoring the instructions marked by this symbol and erroneously operating the product could result in death or serious injury.
 <b>Caution</b>	Ignoring the instructions marked by this symbol and erroneously operating the product could result in injury or property damage.

### Example Pictographs



The  pictograph means "Caution is required".

















The  pictograph means "Should not be done".



The  pictograph means "Must be done".





# Warning



 <b>Do not use the voltage other than specified</b>	<ul style="list-style-type: none"> <li>Do not use the power supply voltage other than the one specified. Doing so could result in a fire or electric shock.</li> </ul>
 <b>Do not use in hazardous locations</b>	<ul style="list-style-type: none"> <li>The product is not explosion proof certified. Do not use in a potentially explosive environment or atmosphere. Doing so could result in a fire or explosion.</li> </ul>
 <b>Do not set on an unstable area</b>	<ul style="list-style-type: none"> <li>Do not set the product on an unstable area, such as a wobbly table or slanted area or on an area subject to strong vibration. The product could fall or topple over, possibly resulting in injury.</li> </ul>
 <b>Do not place in high-temperature locations</b>	<ul style="list-style-type: none"> <li>Do not place the product near heating equipment such as cooking appliances or a heater, or in high-temperature locations. Doing so could damage the product or result in a fire or electric shock.</li> </ul>
 <b>When the product is dropped or breaks</b>	<ul style="list-style-type: none"> <li>If the product is dropped or breaks, immediately power it off, unplug the power cord from the outlet, and contact your SATO reseller or technical support. Using the product in one of these conditions could result in a fire or electric shock.</li> </ul>
 <b>Handling the power cord and other cables</b>	<ul style="list-style-type: none"> <li>Do not damage, break, or alter the power cord and other cables. Also, do not place heavy objects on the power cord or other cables, apply heat to them, place them in high-temperature locations, or forcibly bend, twist, or pull them. Doing so could result in a fire or electric shock.</li> <li>Do not splash water on the power cord or other cables or get them wet. Doing so could result in damage or electric shock.</li> <li>If the power cord and other cables become damaged (core is exposed, wires broken, deformed, etc.), contact your SATO reseller or technical support. Using the power cord and other cables in this condition could result in a fire or electric shock.</li> <li>The dedicated power cord included in the package is to be used specifically for this product. Do not use it for other electronic products. Also, do not use the power cord of other products for this product. Doing so could result in a fire or electric shock.</li> </ul>

 <p><b>Always ground the connections</b></p>	<ul style="list-style-type: none"> <li>Always connect the product's ground wire to a ground. Not grounding the ground wire could result in electric shock. Also, product operations could be affected by interference from electrical noise.</li> </ul>
 <p><b>Do not use the product when something is abnormal</b></p>	<ul style="list-style-type: none"> <li>Do not use the product if any abnormality such as smoke or an unusual odor is detected. Doing so could result in a fire or electric shock. Immediately power off the product, unplug the power cord from the outlet, and contact your SATO reseller or technical support for repairs.</li> </ul>
 <p><b>Do not place containers holding water or other liquid near the product</b></p>	<ul style="list-style-type: none"> <li>Do not place flower vases, cups, or other containers holding liquids, such as water or chemicals, near the product. If water or chemicals get inside the product, immediately power it off, and contact your SATO reseller or technical support. Using the product in this condition could result in a fire or electric shock.</li> </ul>
 <p><b>Do not drop the product in water</b></p>	<ul style="list-style-type: none"> <li>Do not use the product near a container holding liquid. If the product is dropped into water, immediately power it off, and contact your SATO reseller or technical support. Using the product in this condition could result in a fire or electric shock.</li> </ul>
 <p><b>Do not put objects inside the product</b></p>	<ul style="list-style-type: none"> <li>Do not insert or drop any metal or flammable objects down the opening (cable port, etc.) of the product. If a foreign object gets inside the product, immediately power it off, unplug the power cord from the outlet, and contact your SATO reseller or technical support. Using the product in this condition could result in a fire or electric shock.</li> </ul>
 <p><b>Connecting cables or optional devices</b></p>	<ul style="list-style-type: none"> <li>When connecting a cable or optional device to the product, be sure to turn off each of the devices. If they are connected with the power on, an optional device could move unexpectedly, resulting in injury, electric shock, or damage.</li> <li>When installing a cable or optional device, be sure not to make a mistake in the orientation and steps to install. Otherwise, it could result in injury, fire, electric shock, or damage.</li> <li>Do not use cables other than the ones supplied with the product or recommended by us. Doing so could result in smoke, fire, electric shock, or damage.</li> </ul>
 <p><b>Do not operate with wet hands</b></p>	<ul style="list-style-type: none"> <li>Do not power on/power off the product or plug/unplug the power cord and other cables with wet hands. Doing so could result in electric shock or damage.</li> </ul>
	<ul style="list-style-type: none"> <li>Do not disassemble or modify the product. Doing so could result in a fire or electric shock. Ask your SATO reseller or technical support to conduct internal inspections, adjustments, and repairs.</li> </ul>

<p><b>Do not disassemble the product</b></p>	
 <p><b>Using the cleaning fluid</b></p>	<ul style="list-style-type: none"> <li>• Do not use cleaning fluids other than the ones supplied with the product or recommended by us.</li> <li>• The cleaning fluid is to be strictly kept away from the fire. Never apply heat or place it in the fire.</li> <li>• Keep the fluid out of reach of children to prevent them from accidentally drinking it. If a child accidentally drinks the fluid, immediately consult with a physician.</li> </ul>

## Caution

 <p><b>Do not place the product in areas with high humidity</b></p>	<ul style="list-style-type: none"> <li>• Do not place this product in an area with high humidity or where condensation occurs. If condensation has occurred, immediately power off the product, and avoid using it until it is dried. Using the product while condensation is on it could result in a fire, electric shock, or damage.</li> </ul>
 <p><b>Power cord and other cables</b></p>	<ul style="list-style-type: none"> <li>• Grab a power cord and other cables by the plug when removing from the outlet or connector port. Removing a power cord and other cables by grabbing the cord/cable area could result in exposure of wires, breakage, fire, electric shock, or damage.</li> <li>• Do not place the power cord and other cables near a heater or other sources of heat. Doing so could result in melting of the power cord and other cables sheathing, fire, electric shock, or damage.</li> </ul>
 <p><b>Loading media roll</b></p>	<ul style="list-style-type: none"> <li>• When loading a media roll, be careful not to get your fingers trapped between the media roll and the supply spindle.</li> </ul>
 <p><b>Print head</b></p>	<ul style="list-style-type: none"> <li>• The print head is hot after printing. Be careful not to get burned when replacing media or cleaning immediately after printing.</li> <li>• Do not touch the print head with your bare hands. Doing so could result in injury or damage.</li> <li>• To replace the print head, follow the procedure in the Operator Manual. If the Operator Manual does not contain this procedure, avoid trying to replace it on your own terms, and contact your SATO reseller or technical support.</li> <li>• When opening and closing the print head, make sure that objects other than media do not get caught. Otherwise, it could result in injury or damage.</li> </ul>
	<ul style="list-style-type: none"> <li>• When opening and closing the cover, be careful not to get your fingers trapped in between. Also, firmly hold the cover to prevent it from closing unexpectedly.</li> </ul>

<b>Cover</b>	
 <b>When not using the product for a long time</b>	<ul style="list-style-type: none"><li>• When not using the product for a long time, unplug the power cord from the outlet to maintain safety.</li></ul>
 <b>During maintenance and cleaning</b>	<ul style="list-style-type: none"><li>• When maintaining and cleaning the product, unplug the power cord from the outlet to maintain safety.</li></ul>

## Copyrights

---

Any unauthorized reproduction of the contents of this document, in part or whole, is strictly prohibited.

© 2023 SATO Corporation. All rights reserved.

## Trademarks

---

- The following are registered trademarks of SATO Holdings Corporation and its subsidiaries in Japan, the U.S. and other countries.
  - SATO
  - Stylized SOS (SATO Online Services)
  
- NiceLabel<sup>®</sup> is a trademark or registered trademark of Euro Plus d.o.o.
- Bartender<sup>®</sup> is a trademark of Seagull Scientific, Inc.
- QR Code is a registered trademark of DENSO WAVE INCORPORATED.
- Wi-Fi<sup>®</sup> is a registered trademark of Wi-Fi Alliance.
- The following are trademarks of Wi-Fi Alliance.
  - Wi-Fi Direct<sup>™</sup>
  - Wi-Fi Protected Setup<sup>™</sup>
  - WPA<sup>™</sup>
  - WPA2<sup>™</sup>
  
- Windows and Microsoft Edge are registered trademarks of Microsoft Corporation in the United States.
- Android, YouTube, the YouTube logo, and Google Chrome are trademarks of Google LLC.
- The following are registered trademarks of Apple Inc., registered in the U.S. and other countries.
  - iPad
  - iPhone
  
- IOS is a trademark or registered trademark of Cisco in the U.S. and other countries and is used under license.
- Atheros is a registered trademark of Qualcomm Atheros, Inc.
- Ethernet is a registered trademark of Fuji Xerox Co., Ltd.
- All other trademarks are the property of their respective owners.

---

# What You Can Do with This Product

---

## Features of the Product

---

The main features of the product are as follows:

- Rugged design stands up to rigorous operation in harsh environments
- Stable high-speed printing achieved by combining maximum 16 ips print speed with adjustable backfeed speed
- Equipped with highly legible TFT color 3.5-inch display and LEDs. Quickly identify product status and errors
- Print head and rollers, like platen roller, are easy to replace
- Help videos explain easy operations including loading paper and ribbons as well as replacing consumables
- Supports 31 languages for display and 47 languages for printing scalable fonts
- SBPL (SATO Barcode Printer Language) supported as well as many other printer commands like SZPL
- IPv6, SNMP, NTP, and other protocols supported in various communication interfaces
- Remotely verify product information and change settings via network connection
- Use All-In-One Tool to help control and set up the product
- AEP (Application Enabled Printing) equipped. Simple Standalone mode is standard feature for outputting labels without a computer
- Equipped with One Display mode to operate the product from the applicator's screen
- SOS (SATO Online Services) equipped to monitor product remotely for preventive maintenance and troubleshooting



## Various Ways to Output

---

### Outputting with General-purpose Software

Labels can be easily output by using software, such as the NiceLabel series.

- NiceLabel series

This software has multiple functions and is easy to operate so you can create and print labels with richly versatile layouts.



- For details of the products, contact your SATO sales representative.
-

## Outputting and Controlling with Dedicated Command

A variety of labels and tags can be printed from simple formats to complex formats by sending an SBPL (SATO Barcode Printer Language) command to the product.

In addition, you can print characters, barcodes, and graphics in various styles by combining multiple SBPL commands. There are many functions for modifying the printed items, such as enlarging fonts, specifying a print direction, ruled line, and black and white reverse printing.

For programming references, contact your SATO sales representative or technical support.

## Controlling the Product with External Signal

By using the external signal (EXT) interface, you can connect the product to an external device and print. With the control signal, you can control print operations; such as monitoring the condition of the product, starting printing, and reprinting.

## Outputting with Standalone (AEP) Applications

Labels can be printed by running standalone (AEP) applications within the product.



- For details of the standalone applications, contact your SATO sales representative.
-

## Outputting with Simple Standalone Application

The simple standalone application is preloaded as the initial setting of AEP (Application Enabled Printing) mode.

You can print data saved on a USB memory which is inserted into the USB connector of the product by using the simple standalone application.

Create the label formats for simple standalone printing and output the labels according to the following procedure:

### 1. Use label software, such as NiceLabel, Bartender, etc., to create a label format.



- It is recommended to use SATO printer fonts instead of True Type fonts but it is not a requirement. Graphic images are also acceptable to use.
  - All label objects will be saved as fixed data. It is possible to add variable data to the label format. Contact your SATO sales representative for more information.
- 

### 2. Use Print-to-File option to create the SBPL data stream and save the label output you want to use for standalone printing.



- The following extensions are recognized by the product: .ssa, .txt, .prn, .sbpl (if SBPL is enabled), .zpl (if SZPL is enabled). The extensions are case insensitive. It is recommended for the file name excluding extension to be equal or less than 32 characters in order to fully show on the product screen.
- 

### 3. Copy the label format file to the root folder of a USB memory.

For compatibility with simple standalone mode on S84-ex/S86-ex, the label format can also be saved to the "/PR61/DATA" folder if SBPL is enabled, and to the "/PR61/SZPL" folder if SZPL is enabled.



- Use a USB memory that are formatted to FAT32.
-

- When the product is in Online mode, press the  button on the operator panel to change to Offline mode.



- Press the  button to show the [Settings] menu.



- Input the password if it is enabled.

- Select [Applications] using the  /  buttons, and then press the  button.

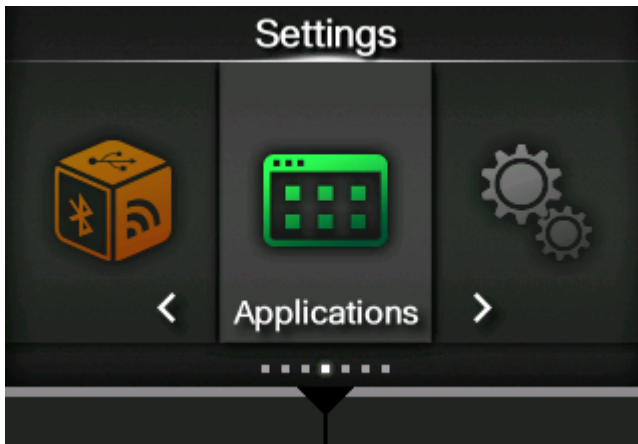

- Select the [AEP] > [Starting Application] menu using the  /  buttons, and then press the  button.

If some applications have already been loaded in this product, select [Simple Standalone] using the ▲ / ▼ buttons, and then press the ← button.

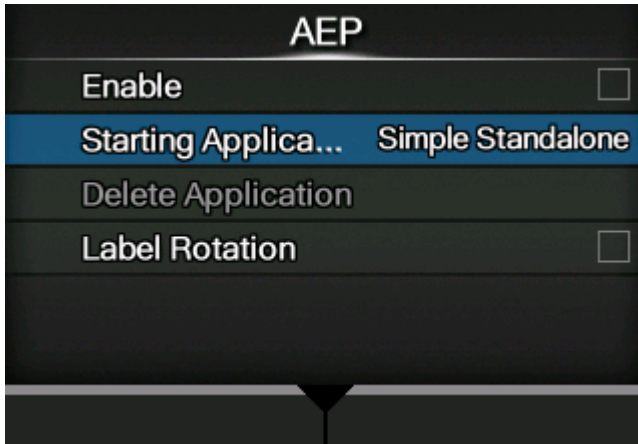

- The simple standalone application is pre-loaded into the product and cannot be removed.

8. Enable AEP mode by selecting the [Enable] menu and reboot the product to apply the settings.

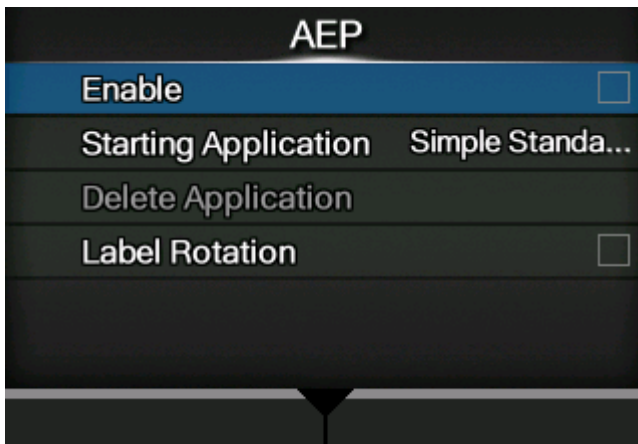

After reboot, the following screen appears.



9. Insert the USB memory into the appropriate location in the product.

Use the USB memory to which the label format file was copied in step 3.

10. Select the format with the ▲ / ▼ buttons, and then press the ← button or the [Enter] button.

The screen shows a list of files without extensions which are stored on the USB memory.



11. If the format contains a variable, enter the variable with the on-screen keyboard or a USB scanner, keyboard or keypad connected to the product.

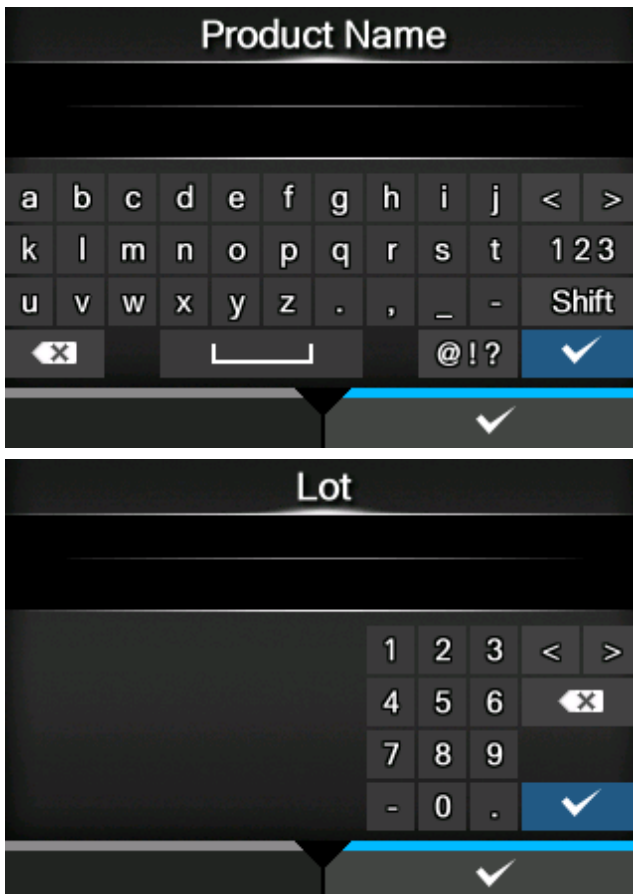



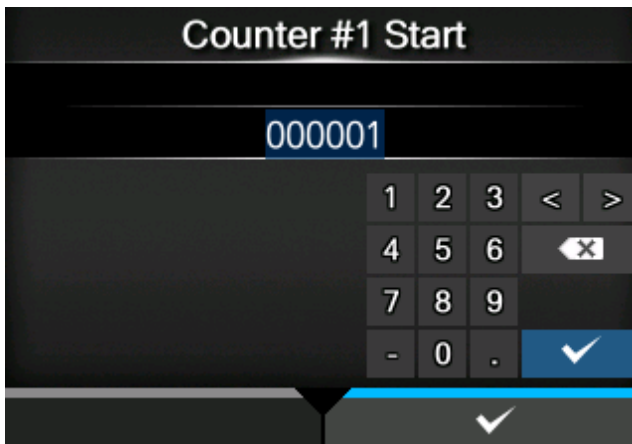

12. If the format contains a counter, enter the start value of the counter with the on-screen keyboard or a USB scanner, keyboard or keypad.

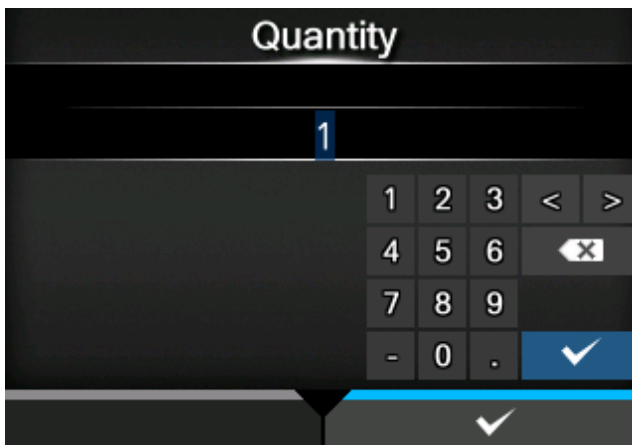

13. Enter the print quantity to start printing the label format.



- Once printing has started, the USB memory can be removed. The USB memory will be required when starting the next print job. Click the  button to reload the USB memory content.

---

# Basic Information

---

## Bundled Accessories

---

After unpacking the product, make sure that you have all the bundled accessories. If there are any missing items, contact the SATO reseller where you purchased the product.

- User documents (Quick Guide, Safety Instructions, Global Warranty Program leaflet, Product Information Download, Declaration of Conformity)

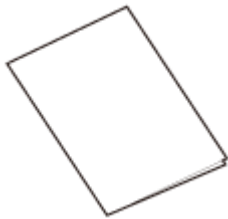

- Power cord

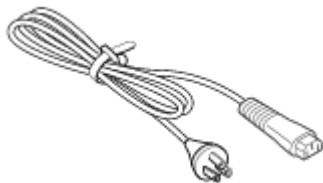

The power cord is not supplied depending on the region in which it was purchased. The shape of power plug varies depending on the region in which it was purchased.

- Ribbon core



- Keep the packaging box and cushioning material after installing the product. You can pack the product with this packaging box for shipment when requesting for repairs.
-

## Optional Devices

---

The optional devices for the product are as follows.

Optional Devices	Description	Supported Models	
		S84NX	S86NX
WLAN 802.11a/b/g/n/ac (2.4 GHz, 5 GHz) <sup>1</sup>	Communicates with the wireless LAN.	Available	Available
EXT conversion cable (25-pin to 14-pin)	Converts the internal 25-pin external signal interface (D-SUB 25-pin, female terminal) to a 14-pin external signal interface (Amphenol 14-pin, female terminal).	Available	Available
UHF RFID kit <sup>1</sup>	Supports UHF RFID. It can read and write to the RFID tag.	Available	-

<sup>1</sup> Cannot be installed after the product is purchased. Contact your SATO sales representative before purchasing the product.



- For more details about the optional devices, contact your SATO sales representative.
-

## Product Orientation

This product has two types of orientation, as shown below. The media feed direction varies depending on the type of orientation.

### Standard/Left-Hand Type

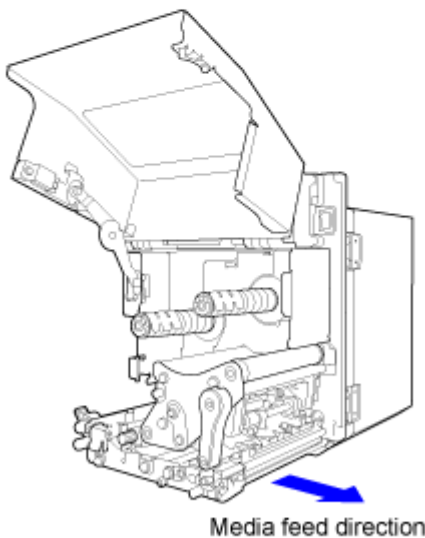
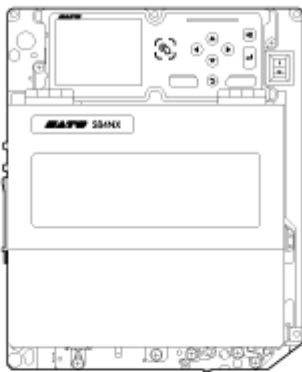

Americas: Standard  
International: Left Hand

### Opposite/Right-Hand Type

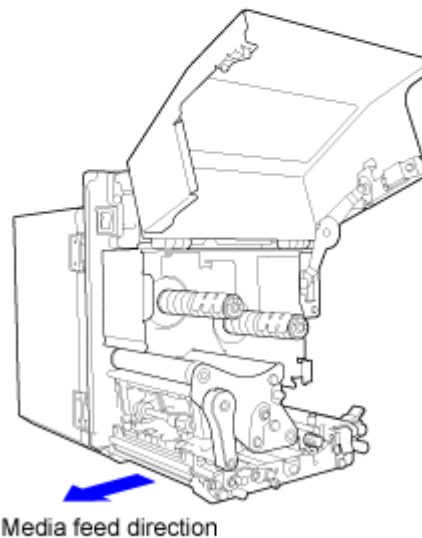
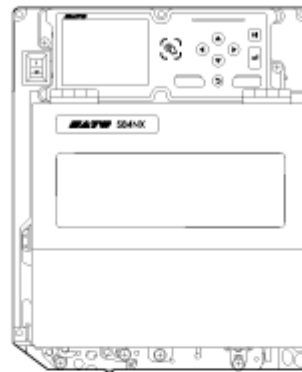

Americas: Opposite  
International: Right Hand



- The illustrations in this manual are of the S84NX (Standard/Left-hand type), unless otherwise noted.
- If you are using the Opposite/Right-hand type, then the illustrations in this manual will appear to be reversed.
- The dimensions of the media compartment in the S86NX are larger.

# Parts Identification

---

## Parts Identification for the Product

### Front View

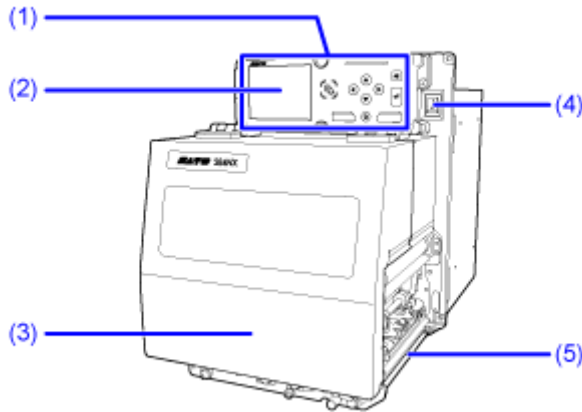

- (1) **Operator panel**
- (2) **Display**
- (3) **Top cover**
- (4) **Power (I/O) switch**  
Press this switch to power on (I) or power off (O) the product.
- (5) **Media discharge outlet**

### Rear View

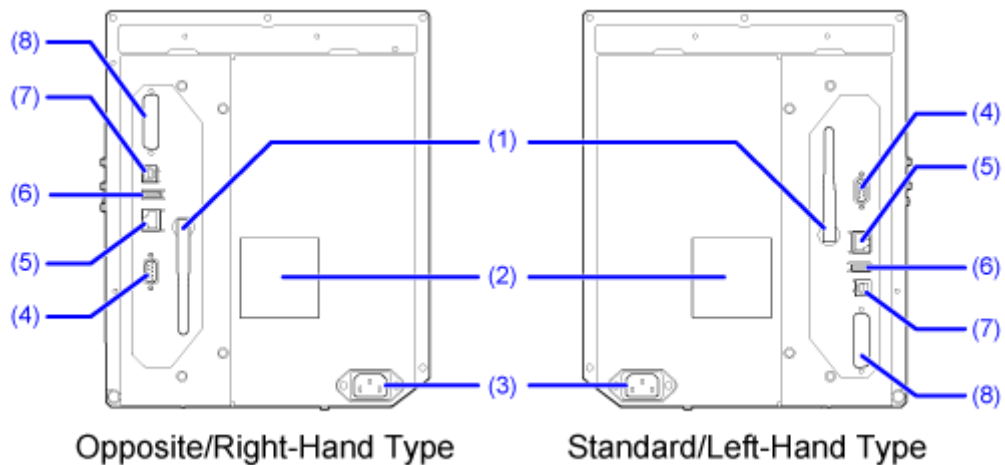

- (1) **Wireless LAN antenna (Optional)**  
Connector for installation of optional wireless LAN antenna.
- (2) **Fan filter**  
To prevent dust from entering the product.

**(3) AC input terminal**

Supplies power to the product through the inserted power cord.

Before connecting, make sure that the AC voltage of your region is in the range of AC 100 to 240 V, 50 to 60 Hz.

**(4) RS-232C connector**

To connect the product to the computer using the RS-232C serial interface.

You can also connect a barcode checker.

Usage of the RS-232C interface can be selected in the [Tools] > [Barcode Checker] > [Test] > [Interface] menu.

**(5) LAN connector**

To connect the product to the network using the LAN interface.

**(6) USB connector (Type A)**

Enable the storage of product settings information with USB memory.

Also, other devices like a barcode checker, barcode scanner or keyboard can be connected.



- Be sure to perform a virus check on the USB memory before connecting it to the product. SATO Corporation shall not be held responsible for any product malfunctions caused by a virus spread via USB memory.
- 

**(7) USB connector (Type B)**

To connect the product to the computer using the USB interface.

**(8) EXT connector (External signal interface)**

Interface connector for external signals. Connect an optional device to this terminal.

## Internal View

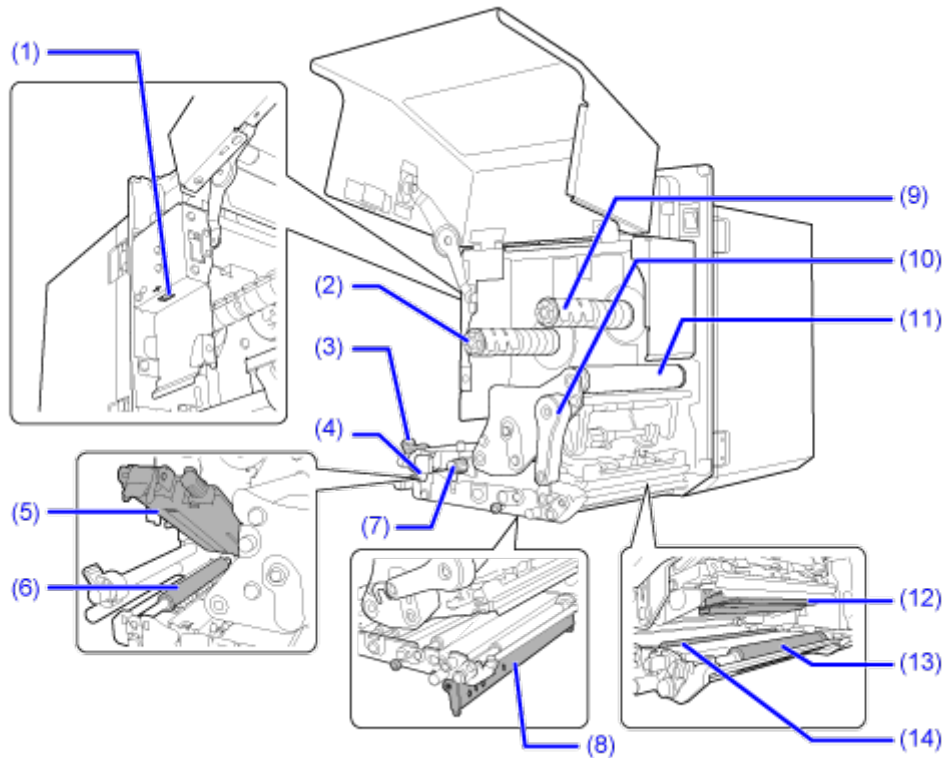

### (1) USB connector (Type A)

Enable the storage of product settings information with USB memory.

Also, other devices like a barcode checker, barcode scanner or keyboard can be connected.



- Be sure to perform a virus check on the USB memory before connecting it to the product. SATO Corporation shall not be held responsible for any product malfunctions caused by a virus spread via USB memory.
- Be sure to insert and remove the USB memory stick perpendicular to the connector.



- The size of the USB memory that can be connected to the side of the product is as follows:
  - Length: under 68 mm (2.68") (excludes the metal part of the connector)
  - Width: under 27.6 mm (1.09")
  - Thickness: under 8.6 mm (0.34")

### (2) Ribbon supply spindle

### (3) Media guide

### (4) Feed lock latch

Used to open the feed roller and media sensor assembly.

### (5) Feed roller and media sensor assembly

### (6) Feed roller (Consumables)

**(7) Media sensor adjustment knob**

Used to adjust the position of the media sensor.

**(8) Pressure plate (Consumables)**

**(9) Ribbon rewind spindle**

**(10) Head lock lever**

Used to release the print head assembly.

**(11) Ribbon roller**

**(12) Print head (Consumables)**

Creates an image directly on the media or by using a ribbon. Clean the print head regularly.

**(13) Platen roller (Consumables)**

**(14) Pressure roller (Consumables)**



## Parts Identification for the Operator Panel

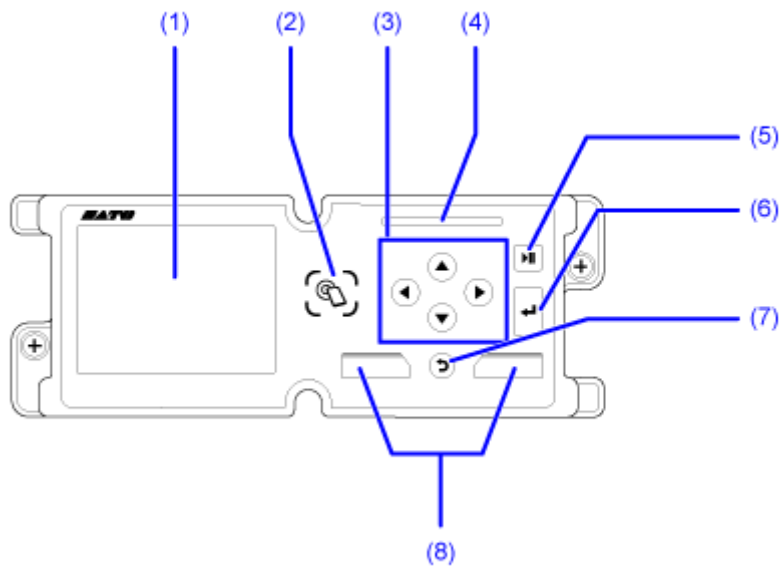

(1) **Display**

(2) **NFC antenna location**

(3)  /  /  /  **Arrow buttons**

Navigate the selection in the screen menu.

(4) **LED indicator**

(5)  **LINE button**

Toggle between Online/Offline mode or playback/pause the video.

(6)  **Enter button**

Confirm the selected item or setting value.

(7)  **Back button**

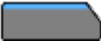
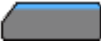

Returns to the previous screen.

(8)   **Soft buttons**

The functions change depending on the screen. The functions of the buttons are indicated on the bottom of the screen.



**Example 1: In Offline mode**



 left soft button: ONLINE,  right soft button: FEED

**Example 2: The numerical value input screen of the Settings menu**







 left soft button: Delete one character,  right soft button: Save

## Using the Operator Panel

---

### LED Indicator

The LED indicator lights up or flashes to show the current status of the product. The product statuses which the LED indicator shows are as follows:

LED Indicator	Color/Status	Description
	Blue/Lights on	Online mode
	Lights off	Power off or Offline mode
	Red/Lights on	Product error (for example, when the ribbon runs out)
	Blue/Flashes	During the powering on process

## Operations in Online/Offline Mode

### Online Mode

In Online mode, you can execute the print job.

In the default settings, the product powers on in Online mode.

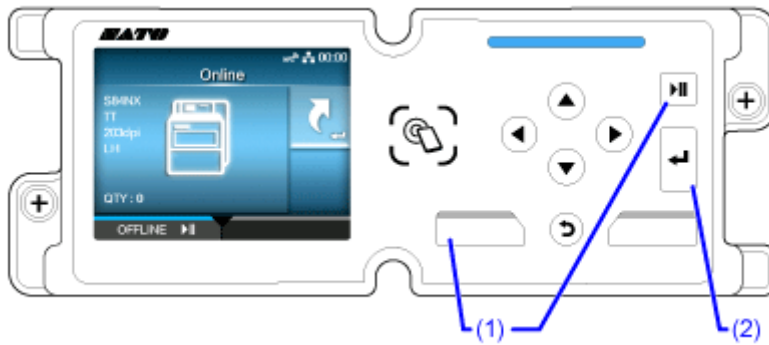

(1) Change to Offline mode.

(2) Shows the [Shortcut] menu.

You can change various settings during printing by registering them to the [Shortcut] menu in advance.



- When setting values are changed from the [Shortcut] menu during printing, the timing at which the changed values are reflected in the printing varies depending on the setting item.
  - Some of the setting items registered to the [Shortcut] menu cannot be changed in Online mode or in Offline mode with the print job (paused).
  - You can use the [Printing] > [Advanced] > [Start Online] menu in the Settings mode to set whether the product starts in Online mode or Offline mode when powering on.
- 

### Offline Mode

In Offline mode, the print job will stop.

You can show the Settings mode, cancel the print job or feed the media.

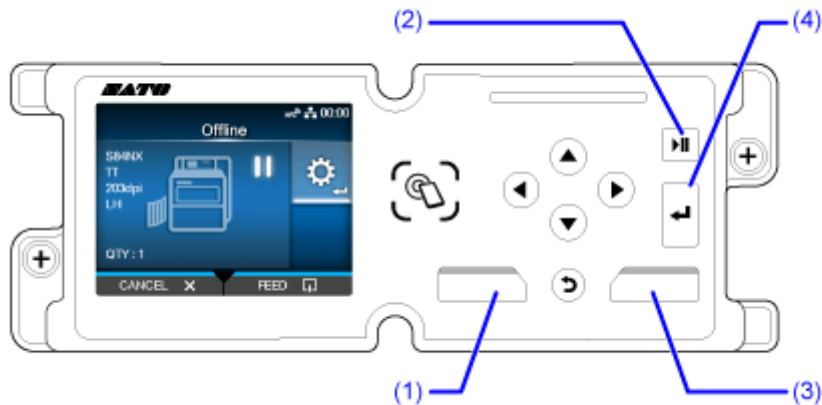

(1) Cancel the print job.

When there are no print jobs, the product changes to Online mode.

(2) Change to Online mode.

(3) Feed the media.

(4) Shows the Settings mode.



- If you enter the Settings mode while the print job is paused, the timing when the value changed in the Settings mode is reflected in the printing varies depending on the setting item.

### Displays Shared in Online/Offline Mode

The following information appears on the left side of the screen.

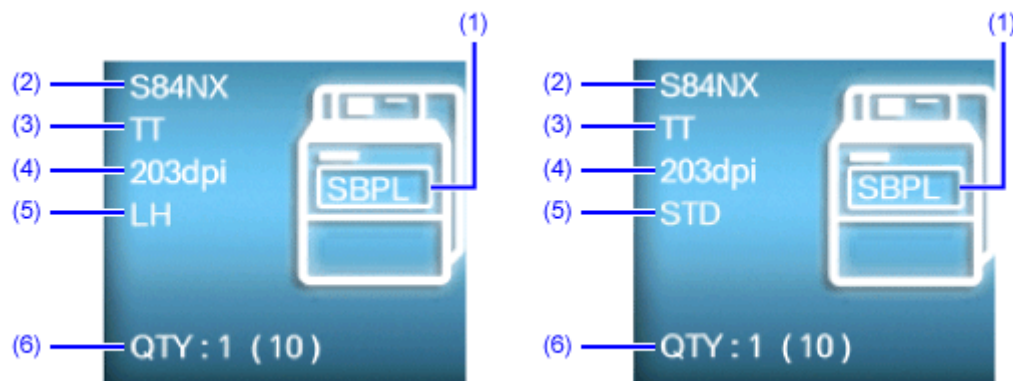

(1) Current printer language

You can set the printer language in the [Applications] > [Protocol] menu in the Settings mode.

(2) Model name

(3) Print Method of the product

Shows whether the product is combined direct thermal/thermal transfer model (TT), or direct thermal only model (DT).

(4) Resolution of the product

(5) Product orientation

Shows either LH/RH or STD/OPP, depending on the country/region in which the product was purchased.

(6) Number of pages in the print job being processed

When the [System] > [Show Total Count] menu in the Settings mode is enabled, the total number of pages printed from after the power was turned on is shown in parentheses.



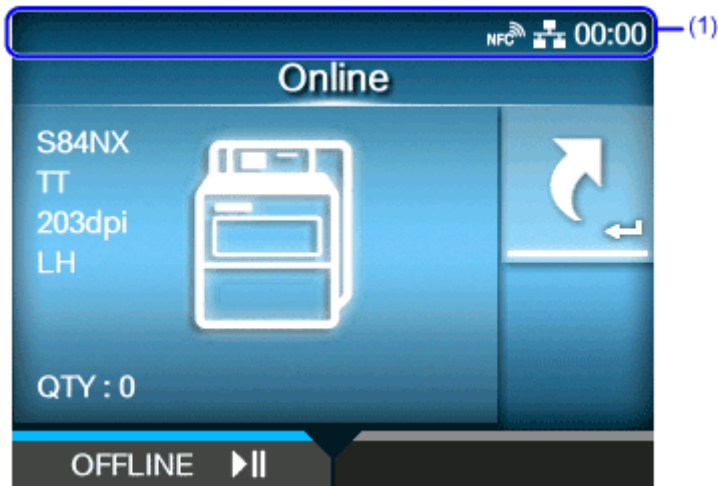

## Status Icon

The icons on the status bar of the display show the product's status.











(1) Status bar



## Communication Interface Status

Icon	Description
	Network link is enabled but not connected.
	NFC is enabled but not connected.
	NFC is enabled and connected.
	Not connected to the NTP time server.
	Wi-Fi is authenticated, but not connected.

Icon	Description
	<p>Wi-Fi is connected. Signal Level: 1</p>
	<p>Wi-Fi is connected. Signal Level: 2</p>
	<p>Wi-Fi is connected. Signal Level: 3</p>
	<p>Wi-Fi is connected. Signal Level: 4</p>
	<p>Wi-Fi Direct is not connected.</p>
	<p>Wi-Fi Direct is connected. Signal Level: 1</p>
	<p>Wi-Fi Direct is connected. Signal Level: 2</p>
	<p>Wi-Fi Direct is connected. Signal Level: 3</p>
	<p>Wi-Fi Direct is connected or the product is set to act as an access point. Signal Level: 4</p>



Icon	Description
	Product is connected to USB host.
	Waiting for external input/output signal.
	RFID mode is enabled. (S84NX only)
	RFID mode is enabled, but the system is defective. (S84NX only)
	Standard code is disabled.
	The On-Demand mode of the SOS (SATO Online Services) is enabled.
	The Real Time mode or the Light mode of the SOS is enabled. The product is connected to the SOS cloud.
	<p>The Real Time mode or the Light mode of the SOS is enabled, but not connected to the SOS cloud.</p> <p>If the LAN or Wi-Fi icon is grayed out, the product is not connected to the network.</p> <p>If the LAN or Wi-Fi icon is active, the Internet connection of the SOS cloud has a trouble.</p>
	The product is not connected to the SOS cloud.

Icon	Description
	Time period set for periodic notification for On-Demand mode for SOS has been reached. Scan the QR code and send the information to the SOS cloud.
	IP address could not be acquired. Or a communication error has occurred.

**USB Memory Status**

Icon	Description
	USB memory is connected.







**Barcode Checker Status**

Icon	Description
	Barcode checker is connected.

**Barcode Scanner Status**

Icon	Description
	Barcode scanner is connected in AEP mode.

## Print Job Status

Icon	Description
	Ribbon is near the end. The rest of the ribbon is decreased. Prepare a new ribbon.
	Label is near the end. The rest of the media is decreased. Prepare new media.
	Command error detected. Check the print data.
	Receive buffer is nearly full. Stop sending print data until the buffer is no longer nearly full.
	Defective print head is detected. Replace the print head.
	Incompatible print head is detected. Replace the print head.

## Maintenance Status

Icons notify you about cleaning the product and replacing parts at the set periods when [Notifications] is enabled.

Icon	Description
	Clean the print head or platen roller.

Icon	Description
	<p>Replace the print head.</p>
	<p>Replace the platen roller.</p>
	<p>Replace the belt (Gear Box).</p>
	<p>Replace the belt (Ribbon).</p>

## Operations When Errors Occur

When a product error occurs, an icon and message (the error and solution) for the error appear on the display. When an error occurs, you can perform the following operations:

- Change to Offline mode.
- Cancel the error.
- Feed the media.
- Change to Settings mode.
- Change to guidance video.
- Change to the SOS error screen on which the QR code and phone number are displayed if the SOS (SATO Online Services) is enabled.



- The available operations vary, depending on the situation.

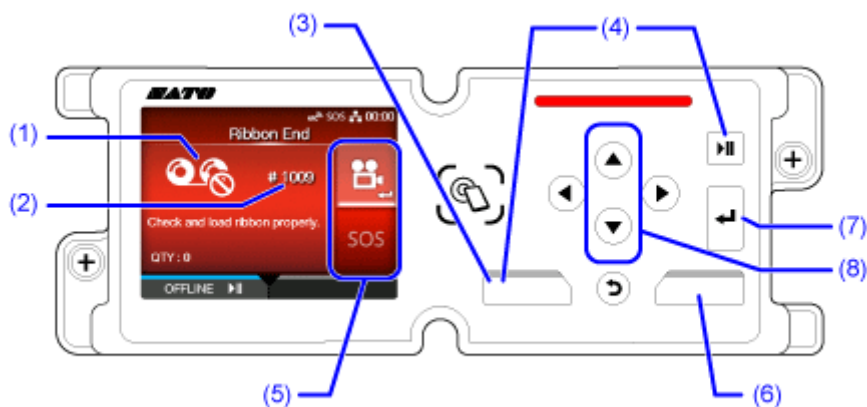

(1) Error Icon

(2) Error number

(3) Clear the error if allowed for the active error.

(4) Change to Offline mode if allowed for the active error.

(5) The icon appears when the Settings mode or guidance video is available.

The SOS icon appears when the SOS is enabled.

(6) Feed the media if allowed for the active error.

(7) Change to Settings mode or guidance video.

Change to the SOS error screen on which the QR code and phone number are displayed if the SOS is enabled.

(8) When there are two icons on the area, select the icon by using ▲ / ▼ buttons. The selected icon will be highlighted.

## Adjusting the Print Settings During Printing

You can change various settings during printing by registering them to the [Shortcut] menu in advance. Follow the procedure below to adjust the setting items registered to the [Shortcut] menu during printing.

1. Press the  button.

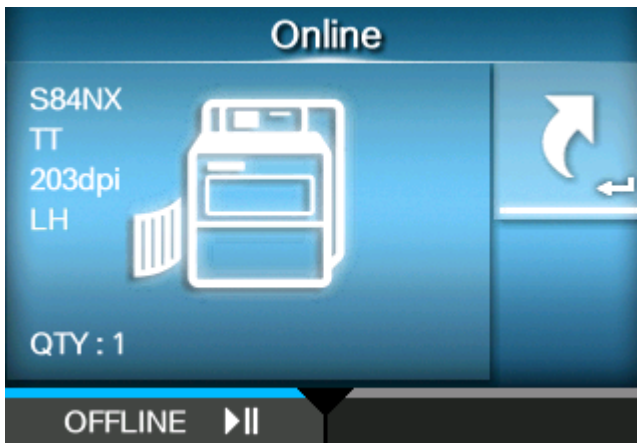

The [Shortcut] menu appears.

2. Select an item and adjust the setting.



- When setting values are changed from the [Shortcut] menu during printing, the timing at which the changed values are reflected in the printing varies depending on the setting item.
- Some of the setting items registered to the [Shortcut] menu cannot be changed in Online mode or in Offline mode with the print job (paused).
- When [Printing] > [Advanced] > [Prioritize] menu has been set to [Commands] and the print settings have been specified by command, the changes made in the [Shortcut] menu will be applied only to the data already analyzed at that time. The settings specified by command will be applied to the rest of the data.

## Canceling the Print Job

Cancel the print job according to the following procedure. When the print job is canceled, the data stored in the receive buffer of the product is also deleted.

1. Press the  button or  button to change the product to Offline mode.
2. Press the  button.



A confirmation message appears.

3. Select whether to cancel all print data or only the current job using the  /  buttons.

The option appears only when the printer language of the print data is SBPL, SDPL, or SZPL.

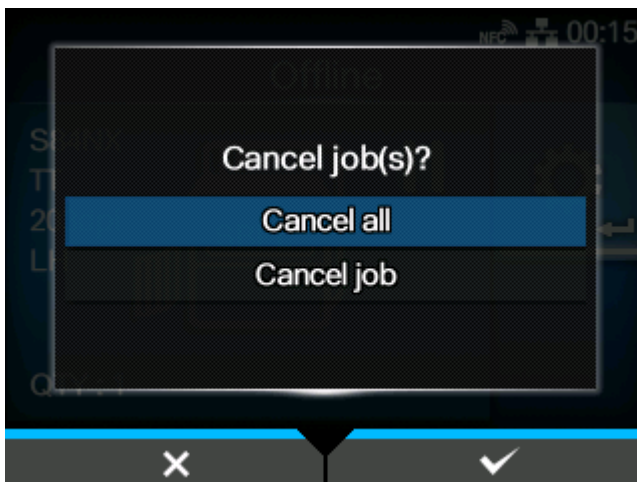

4. Press the  button.

When the printer language of the print data is SBPL, SDPL, or SZPL

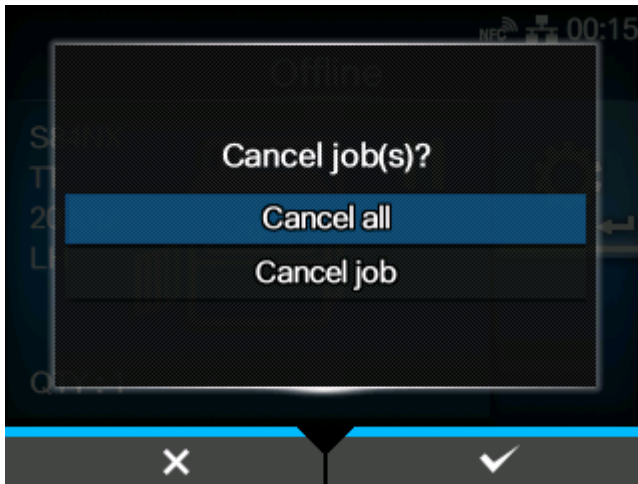

When the printer language of the print data is some other language

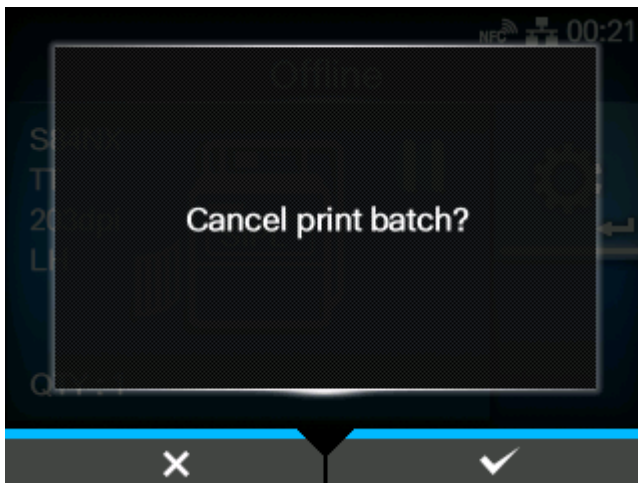

The print job is canceled.



## Guidance Videos

---

The product contains guidance videos that are shown on the display for visual reference of the product's operations.

## List of the Guidance Videos

The product contains the guidance videos for visual reference of product operations.

The onboard guidance videos are as follows:

Guidance video	Show video from		
	Error screen	Startup Guide	[Information] Menu
Media loading	-	Possible	Possible
Ribbon loading <sup>1</sup>	-	Possible	Possible
Media replacement	Possible	-	Possible
Ribbon replacement <sup>1</sup>	Possible	-	Possible
Cleaning the print head	-	-	Possible
Cleaning the rollers	-	-	Possible
Cleaning the media route	-	-	Possible
Cleaning the ribbon route <sup>1</sup>	-	-	Possible
Print head replacement	-	-	Possible
Platen replacement	-	-	Possible
Pressure roller replacement	-	-	Possible
Pressure plate replacement	-	-	Possible
Feed roller replacement	-	-	Possible
Fan filter replacement	-	-	Possible

<sup>1</sup> Available only for the combined direct thermal/thermal transfer model.



- The video displayed on the product is preset according to the model and product orientation.
-

## Playing the Guidance Video from the Error Screen

Play the guidance video from the error screen and resolve the error by following the procedure of the video.

1. On the error screen, press the  button to play the guidance video.





If there are more videos to choose from, press the arrow buttons to select the guidance video, and then press the  button. The guidance video starts.

2. Follow the procedures to resolve the error according to the guidance video.

## Getting Access to the Guidance Video in Online Mode

When in the Online mode, play the guidance video according to the following procedure.

1. Press the  button or  button in Online mode.

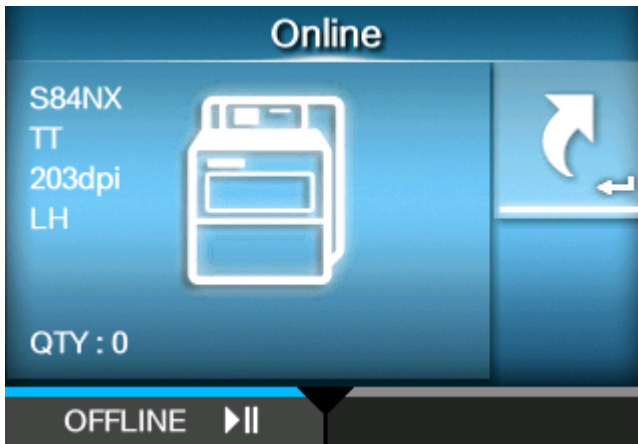

The product changes to Offline mode.

2. Press the  button.



The product changes to Settings mode.

3. Select [Information] using the ◀/▶ buttons.

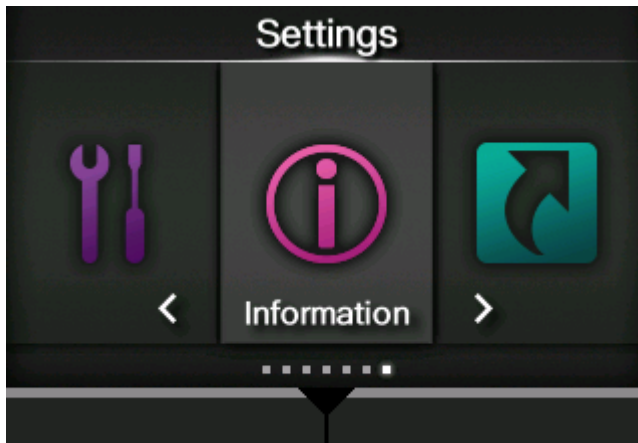

4. Press the ← button.

The item list appears.

5. Select [Help] using the ▲/▼ buttons.

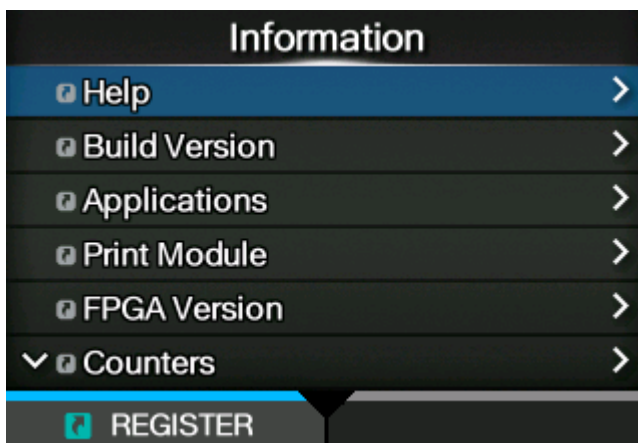



6. Press the ← button.

The guidance video list appears.

7. Select the category of the video for playback using the  /  buttons, and then press the  button.



8. Select the video for playback using the  /  buttons, and then press the  button.

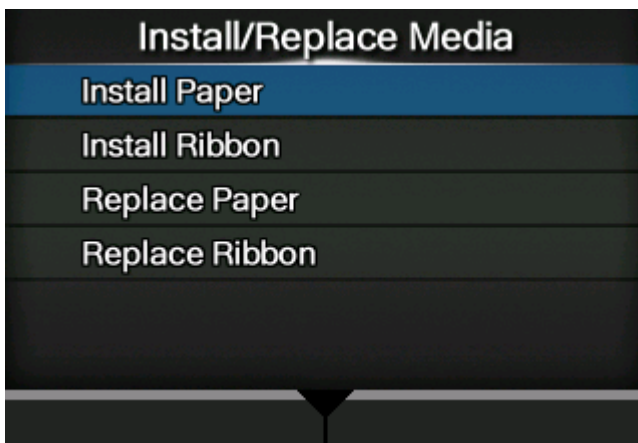

The guidance video starts.

## Operating the Guidance Video

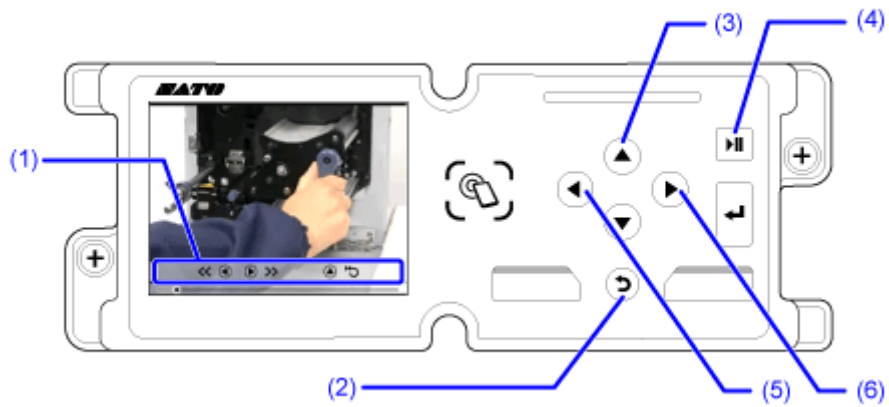

- (1) Indication panel appears again when one of the buttons is pressed.
- (2) Stop the playback of the video and return to menu.
- (3) Playback the video from the start.
- (4) Playback or pause the video.
- (5) Rewind the video.
- (6) Fast-forward the video.

## Settings Mode

---

In the Settings mode, you can set the product's various settings. The topics here explain how to operate the Settings mode.



## Settings Mode Menus

There are the following main menus in the Settings mode and each menu contains many layers of submenus. By registering setting items to the [Shortcut] menu, you can directly access registered setting items and change the settings during printing.





Menu	Description
<a href="#">Shortcut Menu</a>	Directly access the settings registered in advance as well as adjusting registered setting items during printing.
<a href="#">Printing Menu</a>	Access the settings related to printing.
<a href="#">Interface Menu</a>	Access the settings related to the interfaces.
<a href="#">Applications Menu</a>	Access the settings related to the printer command.
<a href="#">System Menu</a>	Access the settings related to the display language, buzzer volume etc.
<a href="#">Tools Menu</a>	Access the test print, initialization and other settings.
<a href="#">Information Menu</a>	Displays the information and guidance videos for the product.



- The  icon appears between the [Information] menu and [Shortcut] menu when the [System] > [Regional] > [Display Language Icon] menu is enabled. You can easily access the [Language] menu.

## Changing to the Settings Mode

Change the product to the Settings mode according to the following procedure:

1. Press the  button or  button in Online mode.





The product changes to Offline mode.

2. Press the  button.

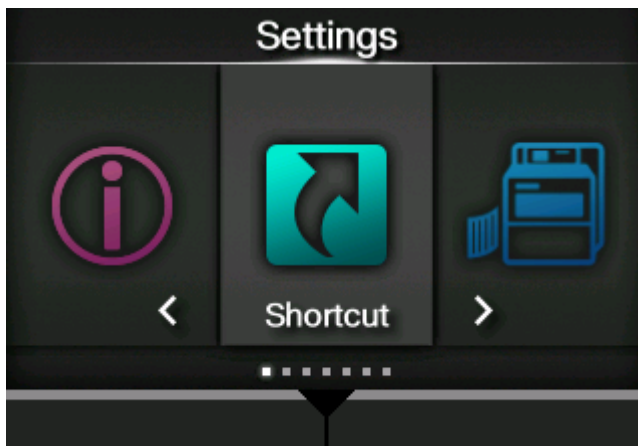

The product changes to Settings mode.



- To exit the Settings mode, press the  button.
  - If you enter the Settings mode while the print job is paused, the timing when the value changed in the Settings mode is reflected in the printing varies depending on the setting item.
-

## Logging In to/Logging Out of the Settings Mode

The Settings mode logs in and logs out by the following procedure, if the password is enabled.

- If the password is enabled, input the password after entering the Settings mode.

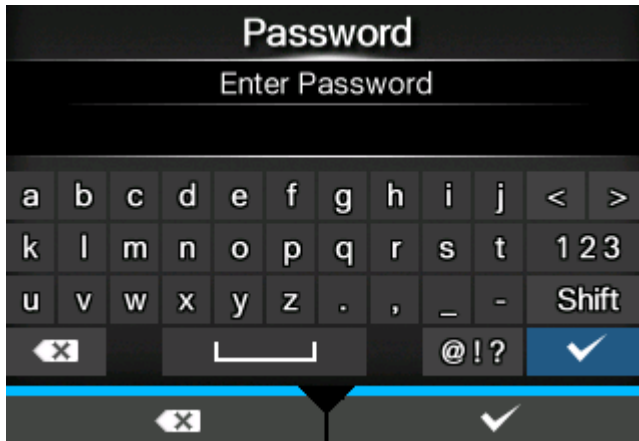

When logged in to the Settings mode, [LOG OUT] appears on the bottom left of the screen.

- Press the  button to log out of the Settings mode.

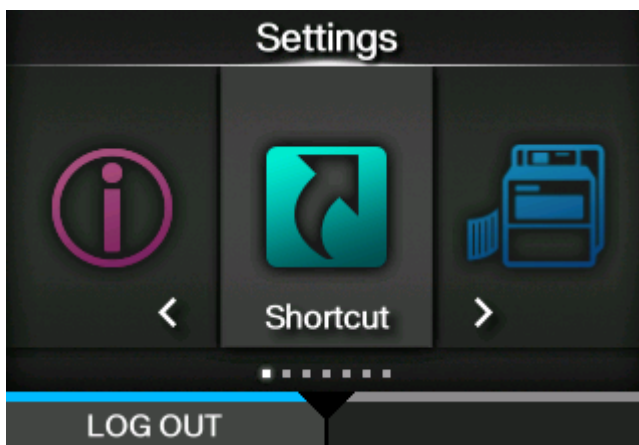

Password is required to enter the Settings mode again.



- With password enabled, if no button is pressed for about 10 minutes after login, the login session will end automatically. Password is required to enter the Settings mode again.

## Item Selection

Select an item in Settings mode according to the following procedure:

1. Select menu using the ◀/▶ buttons.
2. Press the ← button.

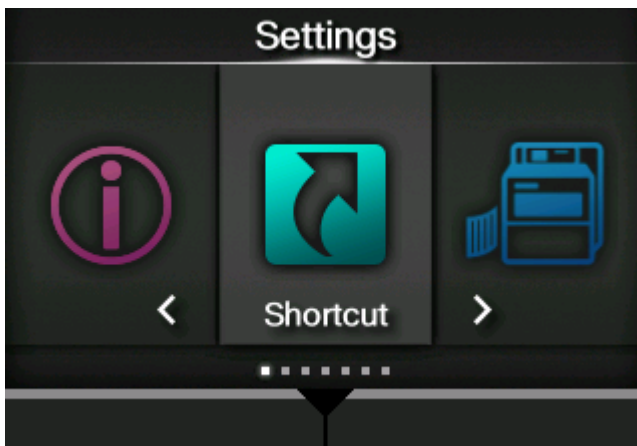

The item list appears.

3. Select an item using the ▲ / ▼ buttons.
4. Press the ← button.

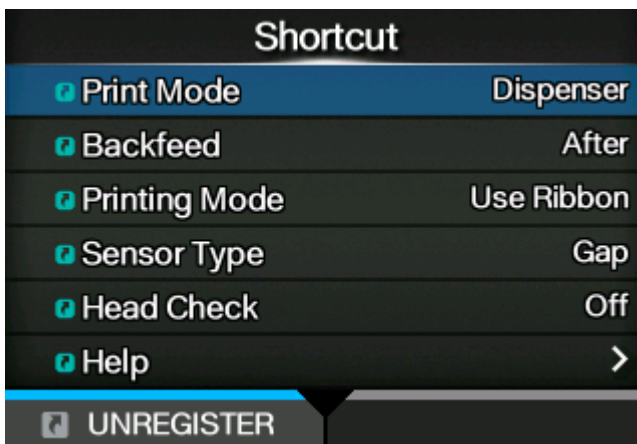

If the selected item is a setting item, the setting screen appears.

If the selected item is a handling item such as the auto calibration, copy, or delete, the starting screen or confirmation screen appears.

Items with a [>] indicated on the right side have more items in the next layer of the submenu.

Press the ▶ or ← button to show the next layer.

Similarly, select an item using the ▲ / ▼ and ← buttons.

Press the ↶ button to return to the previous screen.

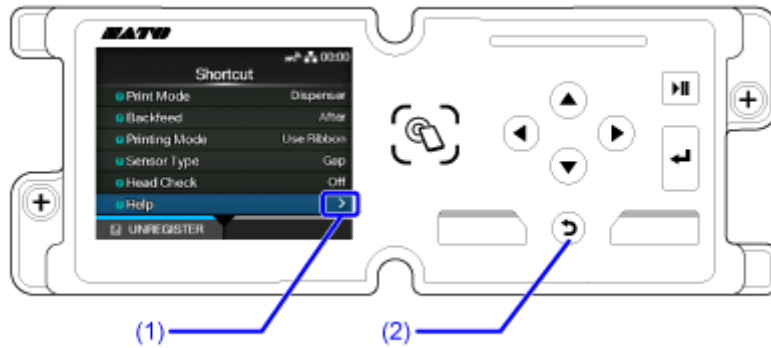

(1) There are more items in the next layer.

(2) Return to the previous screen.

## Setting Value Input or Selection

This topic describes the character and number input on the setting screen and how to select an item from the list.



- You can also input characters and numbers from a USB keyboard by connecting it to the product.

- [Character Input](#)
- [Numeric Input](#)
- [Selection from the List](#)
- [Selection from the Box](#)
- [IP Address Input](#)

- Character Input**

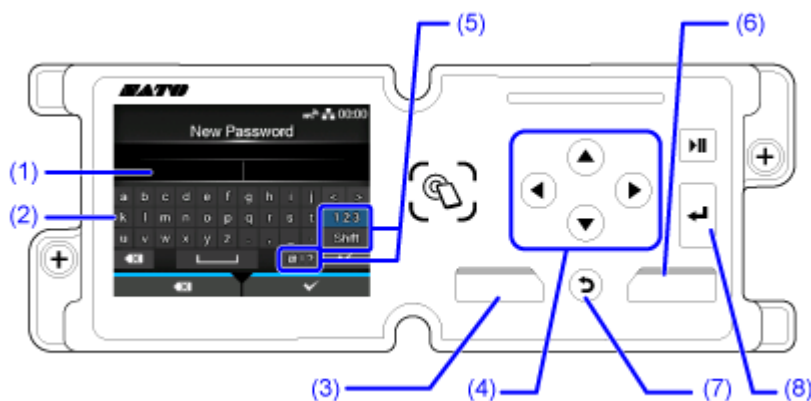

- (1) Text box
- (2) Selection area
- (3) Delete the character displayed to the left of the cursor in the text box.
- (4) Select the character for input using the arrow buttons. The selected character will be highlighted in the selection area.
- (5) Change the input mode.
- (6) Save the character you enter in the text box and return to the item list.
- (7) Cancel the character you enter in the text box and return to the item list.
- (8) Enter the selected character into the text box.

- **Numeric Input**

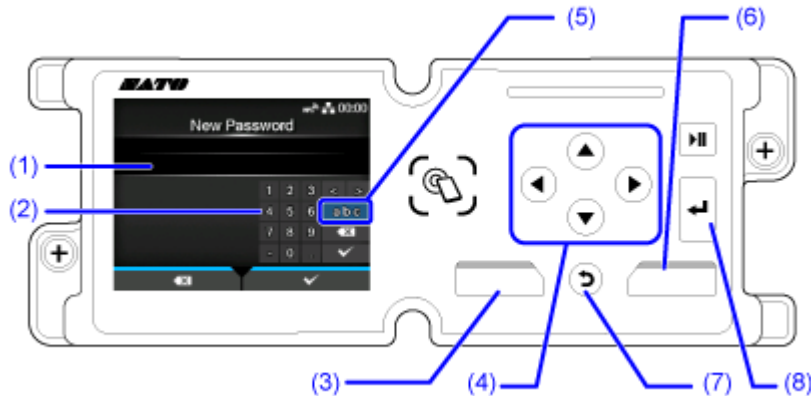

- (1) Text box
- (2) Selection area
- (3) Delete the number displayed to the left of the cursor in the text box.
- (4) Select the number for input using the arrow buttons. The selected number will be highlighted in the selection area.
- (5) Change the input mode.
- (6) Save the number you enter in the text box and return to the item list.
- (7) Cancel the number you enter in the text box and return to the item list.
- (8) Enter the selected number into the text box.

- **Selection from the List**

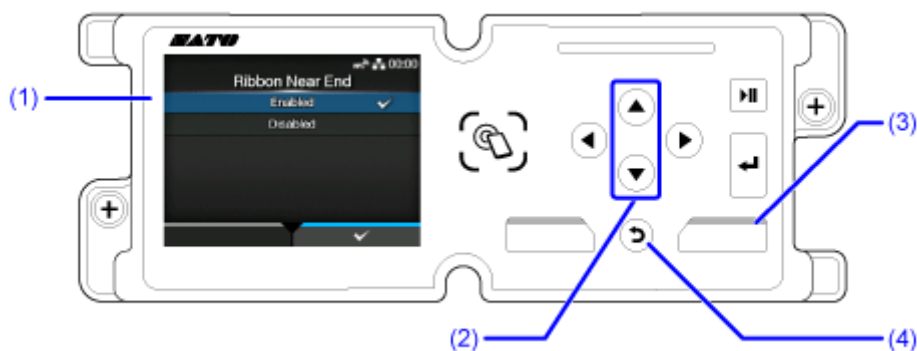

- (1) Selection area
- (2) Select an item using the ▲ / ▼ buttons. The selected item will be highlighted in the selection area.
- (3) Save the selection from the list and return to the item list.
- (4) Cancel the selection from the list and return to the item list.



- **Selection from the Box**

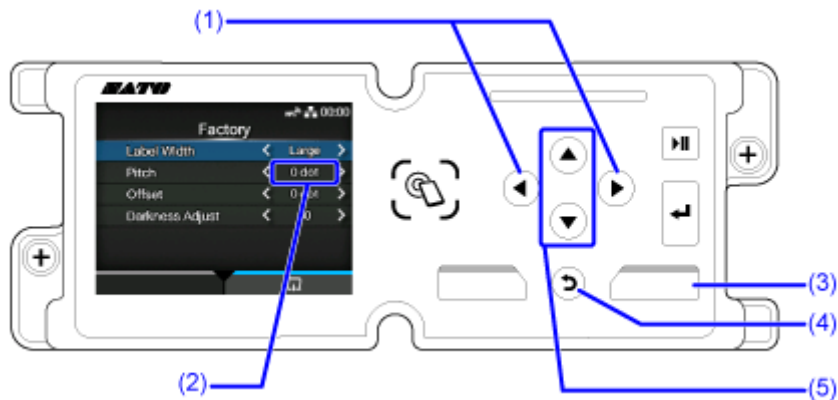

(1) Change the value in the selection box using the ◀/▶ buttons.

(2) Selection box

(3) Perform the function as shown on the screen.

(4) Return to the previous screen.

(5) Select an item using the ▲/▼ buttons. The selected item will be highlighted in the selection area.

- **IP Address Input**

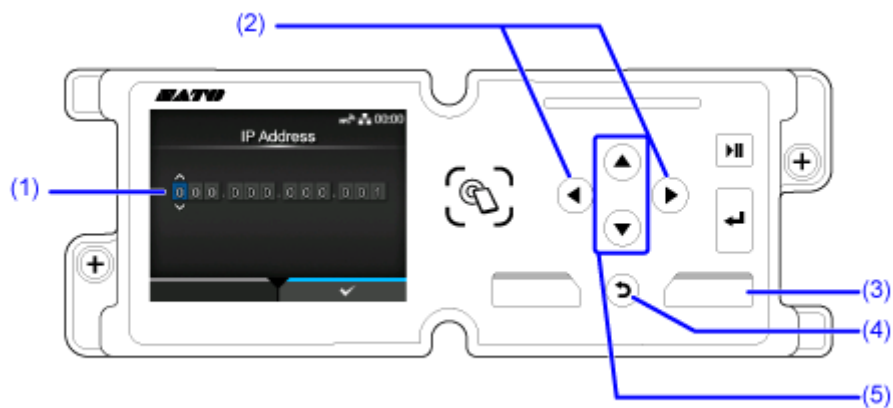

(1) Text box

(2) Select the digit for input using the ◀/▶ buttons.

(3) Save the IP address you enter in the text box and return to the item list.

(4) Cancel the IP address you enter in the text box and return to the item list.

(5) Select the number to input using the ▲/▼ buttons.

## Customizing the [Shortcut] Menu

By registering setting items to the [Shortcut] menu, you can directly access registered setting items and change the settings during printing.

### Registering Items to the [Shortcut] Menu

You can register items to the [Shortcut] menu according to the following procedure:

1. Select the item to register using the ▲ / ▼ buttons.

If the item can be registered, the  icon is displayed on the left side of the item.

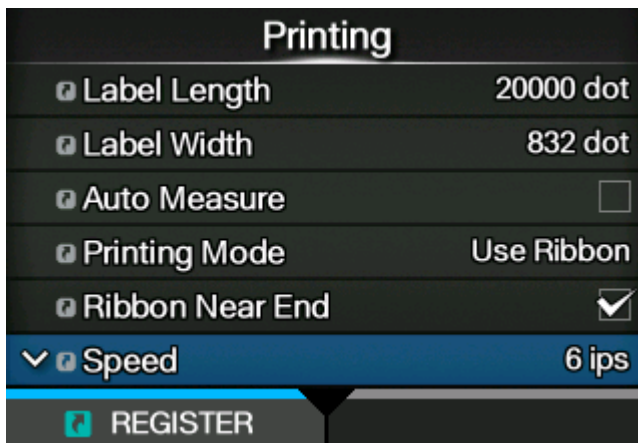

2. Press the  button.

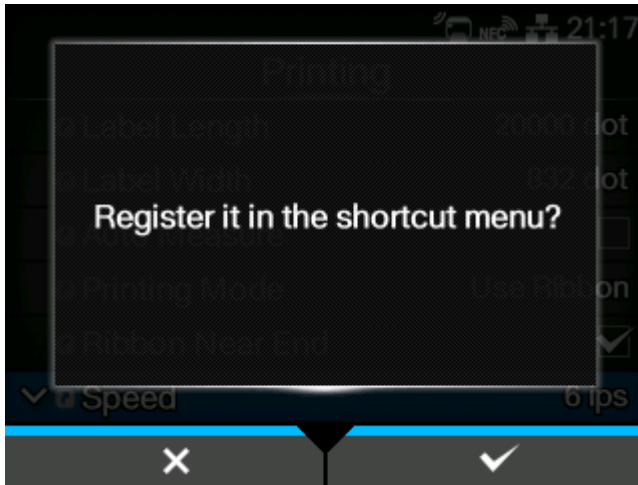

The confirmation screen appears.

3. Press the  button on the confirmation screen.



Registering the item to the [Shortcut] menu is complete, and the  icon turns to the  icon.

## Unregistering Items from the [Shortcut] Menu

You can unregister items from the [Shortcut] menu according to the following procedure:

1. Select the item to unregister using the  /  buttons in the [Shortcut] menu.

If the item is registered in the [Shortcut] menu, the  icon is displayed on the left side of the item.

2. Press the  button.

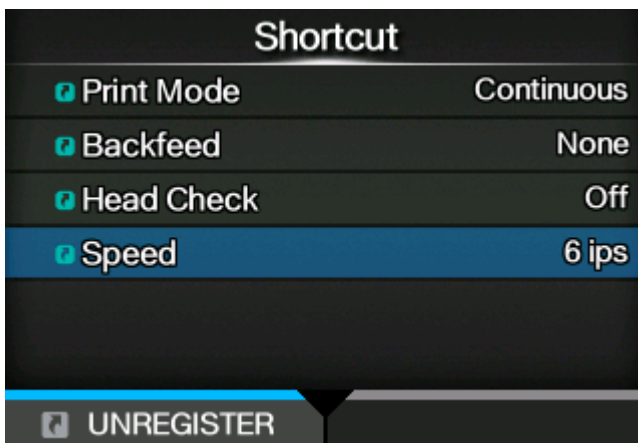

The confirmation screen appears.

3. Press the  button on the confirmation screen.

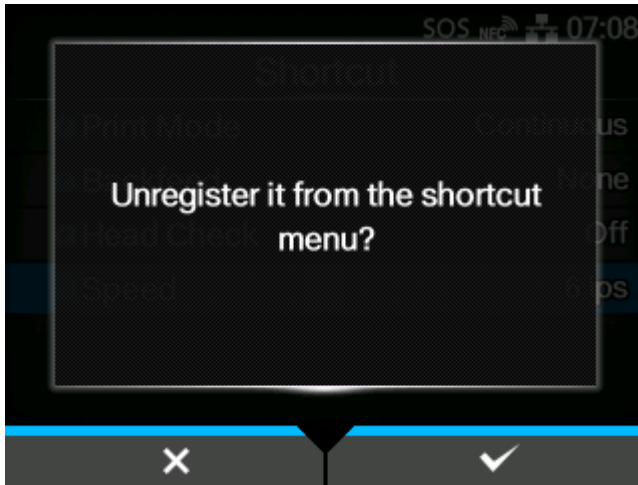

The item is removed from the [Shortcut] menu.



- You can also unregister items on the setting screen relative to each item.

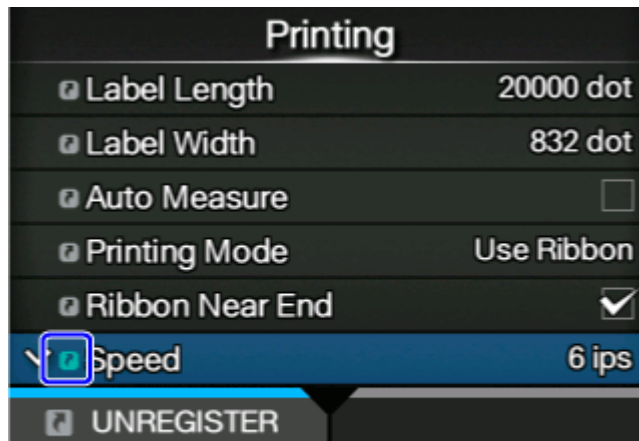

## Product Memory and USB Memory

---

The memory of the user area of the product is a maximum of 576 MB.

However, you cannot use the whole memory of the user area, because this area is also used for the log data and HEX dump functions.

USB memory can be connected to the product. There is no capacity limit for USB memory.

There are two USB connectors (type A) on the back and one side of the product (left side when facing the Standard/Left-hand type product and right side when facing the Opposite/Right-hand type product). USB memory can be connected to either connector.

What you can do with this product while it is connected to USB memory is as follows:

- Get the HEX dump data
- Install certificates used for Wi-Fi authentication and for HTTPS
- Get the barcode check log data
- Create clone data (copy the product's settings information)
- Get the support information



- Be sure to perform a virus check on the USB memory before connecting it to the product. SATO Corporation shall not be held responsible for any product malfunctions caused by a virus spread via USB memory.
- When using the connector on the side of the product, be sure to insert and remove the USB memory stick perpendicular to the connector.



- The product does not support USB memory with security functions such as fingerprint authentications.
  - The product does not support connection through the USB HUB.
  - Use USB memories that are formatted to FAT32.
  - The size of the USB memory that can be connected to the side of the product is as follows:
    - Length: under 68 mm (2.68") (excludes the metal part of the connector)
    - Width: under 27.6 mm (1.09")
    - Thickness: under 8.6 mm (0.34")
-

---

# Getting Started

---

## Installation

---



- When you want to take the product to countries other than where you purchased it, contact your SATO reseller.
-

## Installation Space

### Front View

The dimensions of the front view of the product are as follows:

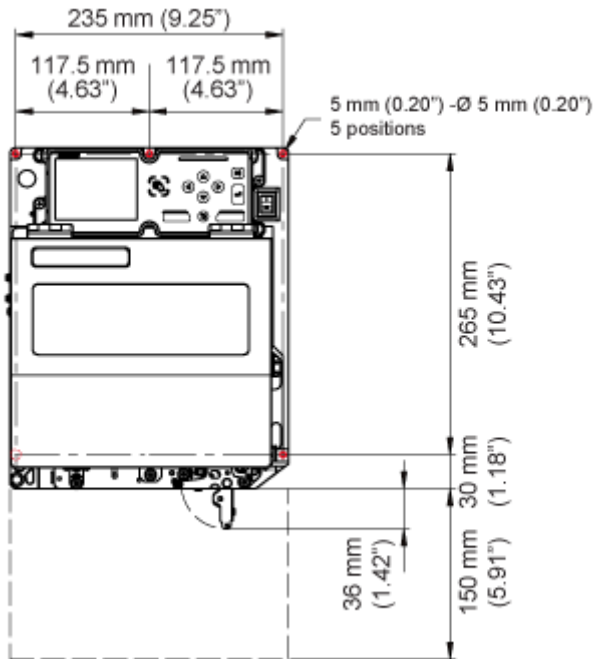

- The encircled positions show the 5 holes for installing the product in the support structure.
- The figure above is the Standard/Left-hand type. If you are using the Opposite/Right-hand type, then the direction is the opposite.

### Rear View

The dimensions of the rear view of the product are as follows:

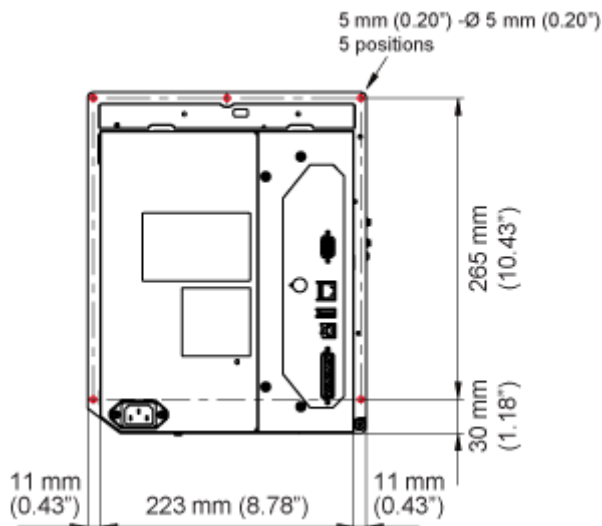

- The encircled positions show the 5 holes for installing the product in the support structure.
- The figure above is the Standard/Left-hand type. If you are using the Opposite/Right-hand type, then the direction is the opposite.

## Media Dispensed View

Make sure that there is sufficient space around the product so that the top cover can be fully opened when operating or cleaning the product, or replacing consumables.

The dimensions of the media dispensed view of the product are as follows:

### S84NX

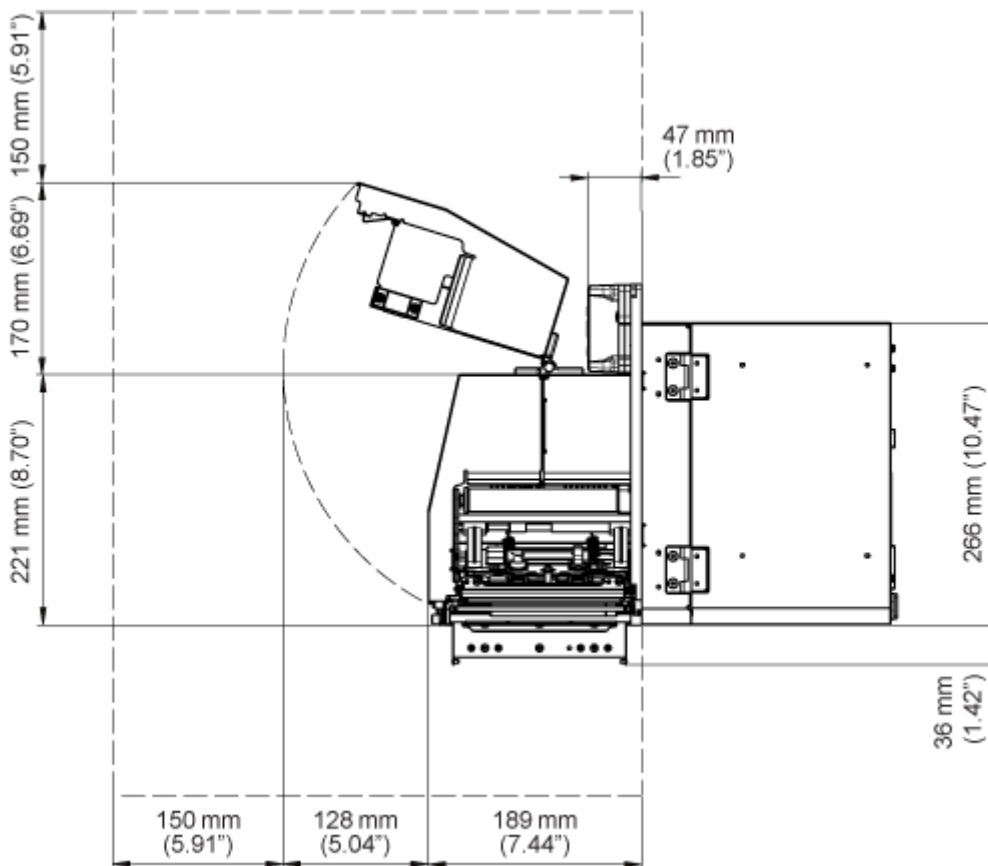

- The figure above is the Standard/Left-hand type. If you are using the Opposite/Right-hand type, then the direction is the opposite.



## S86NX

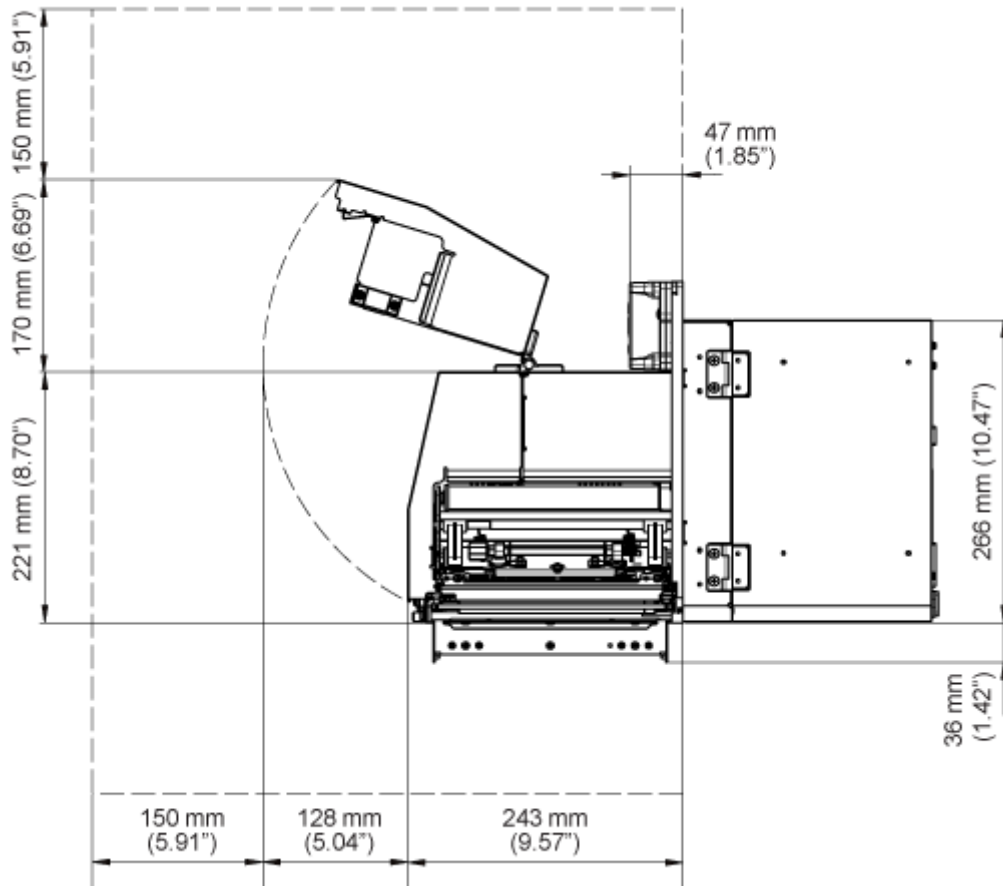

- The figure above is the Standard/Left-hand type. If you are using the Opposite/Right-hand type, then the direction is the opposite.

### Top View

Make sure that there is sufficient space on the rear side of the product so that the rear housing cover can be fully opened during maintenance.

The dimensions of the top view of the product are as follows:

**S84NX**

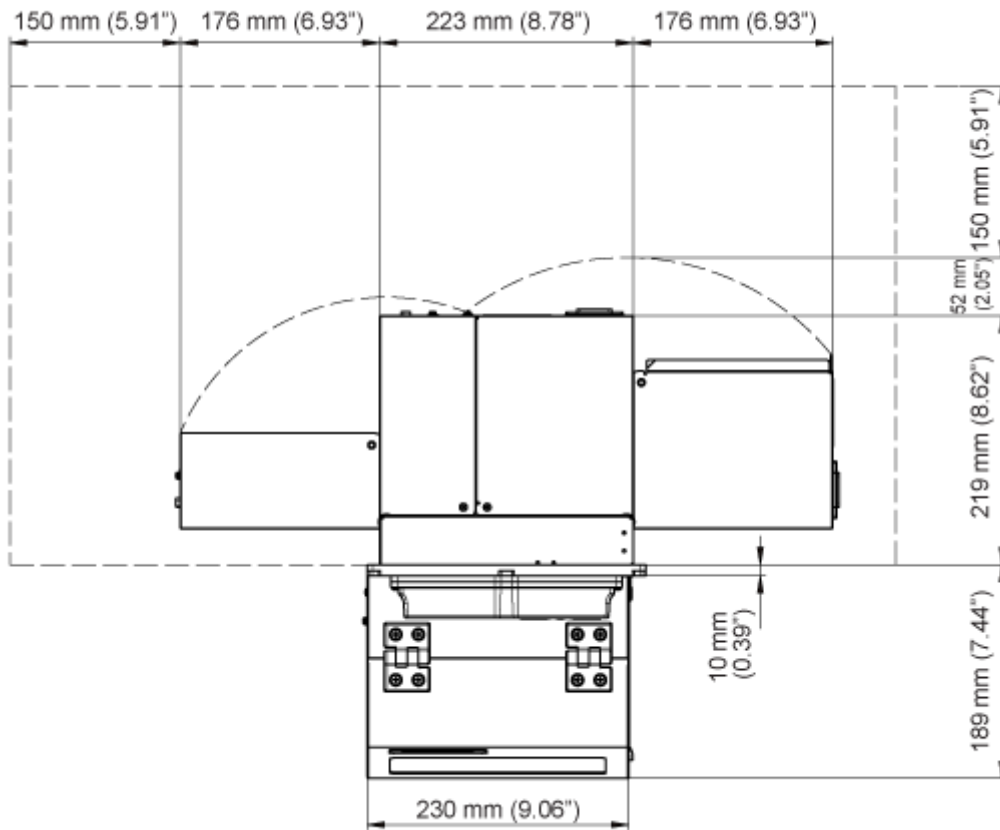

- The figure above is the Standard/Left-hand type. If you are using the Opposite/Right-hand type, then the direction is the opposite.

## S86NX

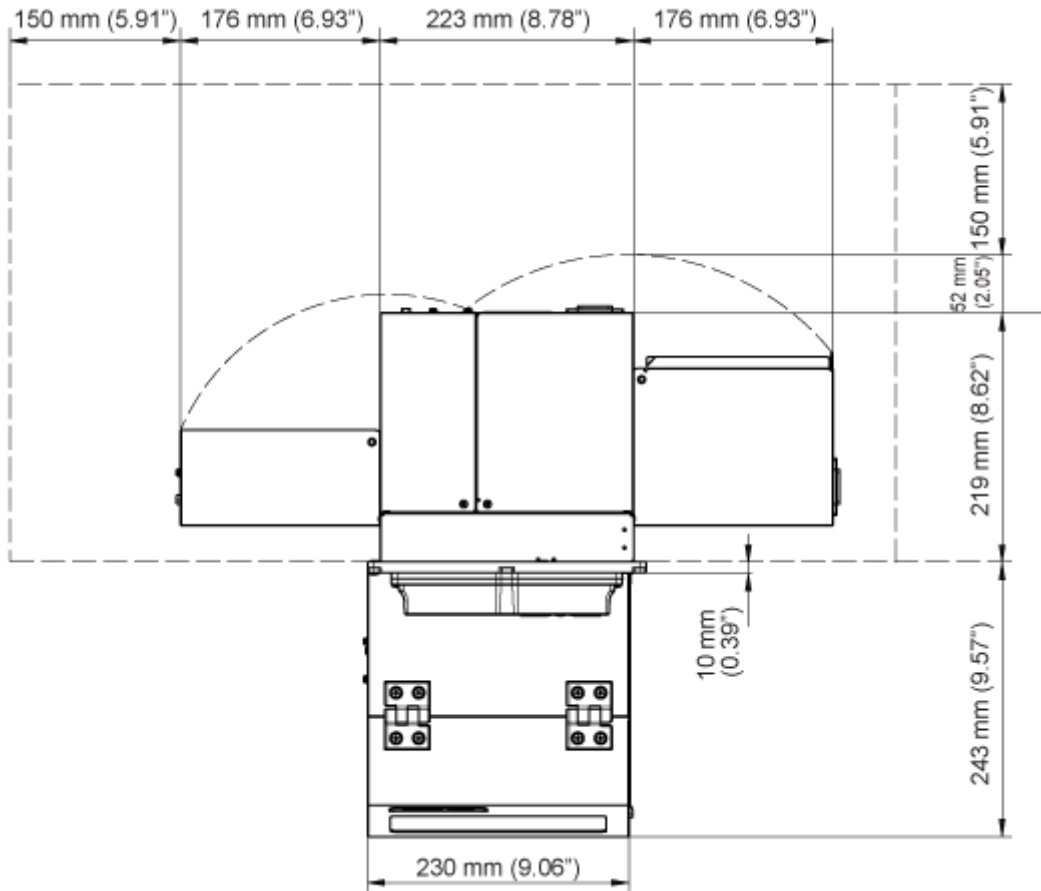

- The figure above is the Standard/Left-hand type. If you are using the Opposite/Right-hand type, then the direction is the opposite.

## Installing the Product onto a Support Structure/Applicator

To operate correctly, the product must be installed on a support structure or applicator.

The product has five mounting holes on the center frame for installation on a support structure.

Put five bolts through the five holes on the center frame to install the product on the support structure.



- Make sure that you use the designated bolts that can accommodate the weight of the product.

If you do not install the product correctly, it could fall out of the support structure, which could cause an injury.

---



- When installing the product on or removing it from a support structure or applicator, be careful not to get your hands trapped between the product and the support structure or applicator.
- 

The diagram below shows an example of when the product is installed in the support structure.

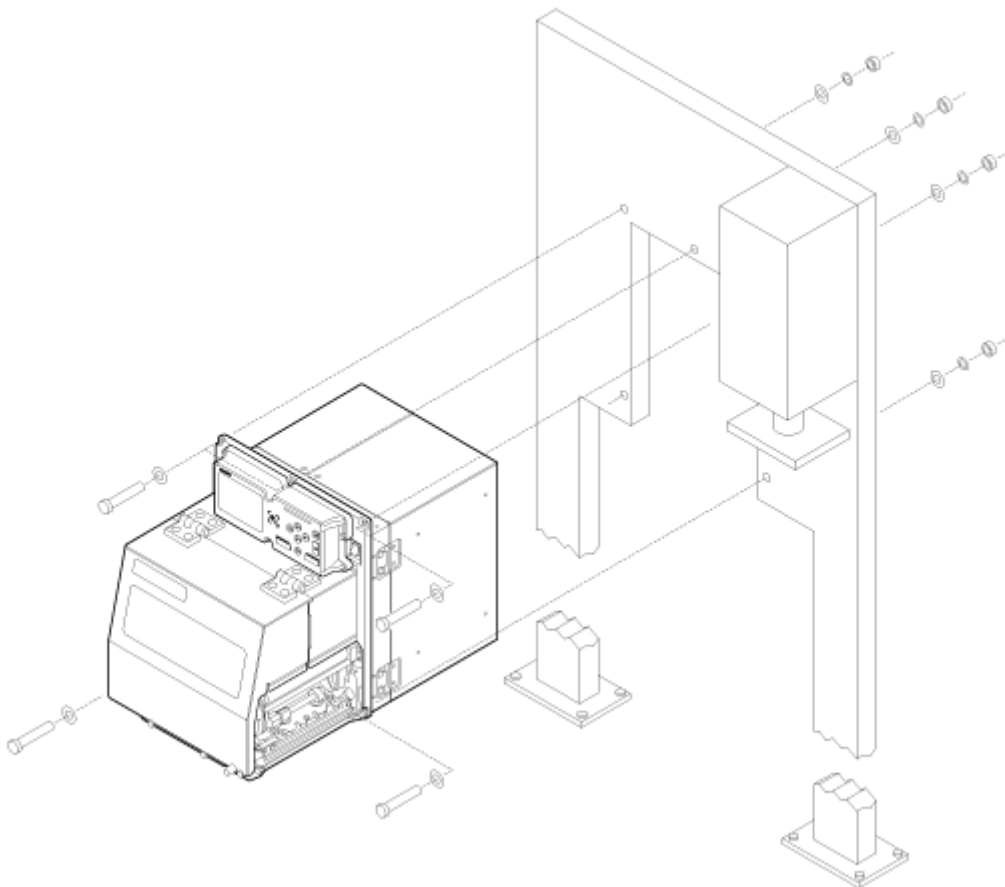

- This diagram is for reference only, it does not accurately show the installation method.
-

# Powering On/Off the Product

---

## Connecting the Power Cord



- Do not power on or off the product, connect or disconnect the power cord while your hands are wet. Doing so could cause an electric shock.
- Always connect the ground wire to a ground terminal. Electric shock could occur if you do not.
- Make sure that the AC voltage of your region is in the range of AC 100 - 240 V, 50 - 60 Hz. If your local voltage is not in the stated range, contact your SATO reseller or technical support.



- The attached power cord is designed exclusively for this product. Do not use it with other devices.

### 1. Connect the power cord to the AC input terminal (1) at the rear of the product.

Take note of the orientation of the connector. Secure the product with one hand, and insert the connector tightly.

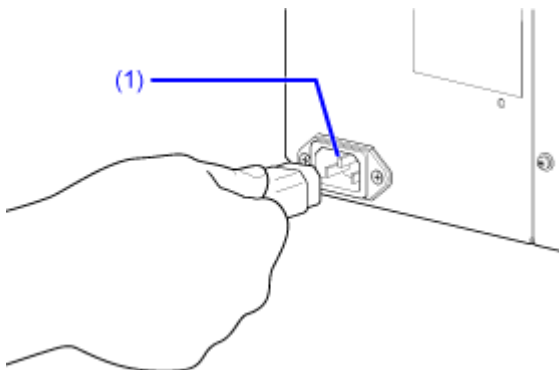

### 2. Insert the power plug into an AC outlet.

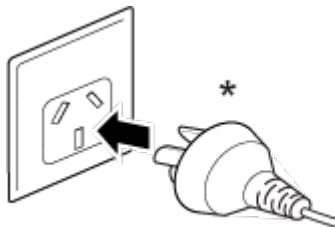

\* The shape of the power plug varies depending on the region in which it was purchased.



- This product is also designed for IT power distribution system with phase-to-phase voltage 230 V.

## Powering On the Product



- Do not power on or off the product, connect or disconnect the power cord while your hands are wet. Doing so could cause an electric shock.

### 1. Press the power (I/O) switch to "I" position.

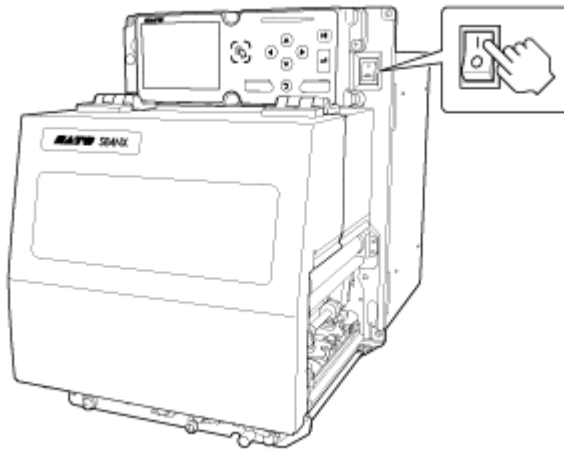

"Online" appears on the screen.





- When you power on the product for the first time after purchase or reboot after resetting the settings, the startup guide appears. You can easily set the printing preferences on the product by following the on-screen instructions.
- The screen that appears after you power on the product varies depending on the settings.
  - If [Start Online] in the [Printing] menu is disabled, the Offline screen appears.
  - If [AEP] in the [Applications] menu is enabled, the application screen appears, depending on the [Starting Application] setting.

- You can power on/off the product from the main power source, from which the product takes its power, because it is equipped with a start on AC function.

To turn the power on and off from the main power source, leave the power (I/O) switch of the product in the "I" position.

---

## Powering Off the Product

- 
- 
    - Do not power on or off the product, connect or disconnect the power cord while your hands are wet. Doing so could cause an electric shock.
- 
- 
    - Do not power off the product during operation, such as when printing or updating. Doing so could cause a malfunction of the product.
    - Do not disconnect the power cord until the powering off process is completed on the product.
    - An incorrect power on/off operation may change or initialize the product's settings.
- 

### 1. Make sure that the product is in Offline mode before you power off.

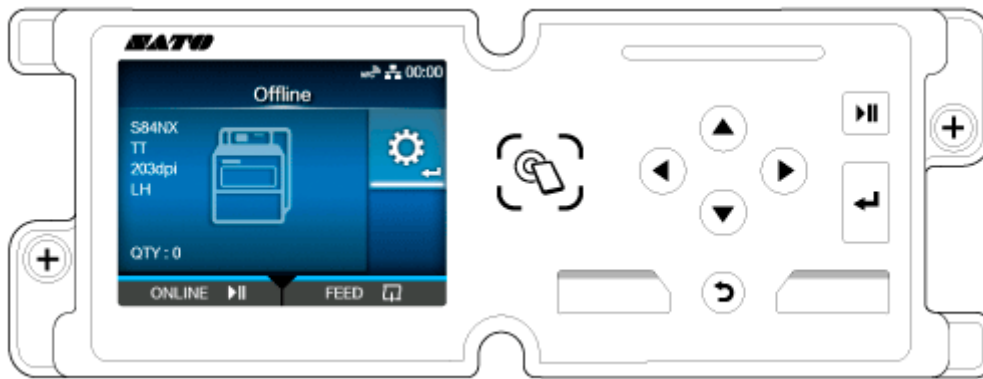

If "Online" appears on the screen, press the  button or  button to change to Offline mode.

### 2. Press the power (I/O) switch to "O" position.

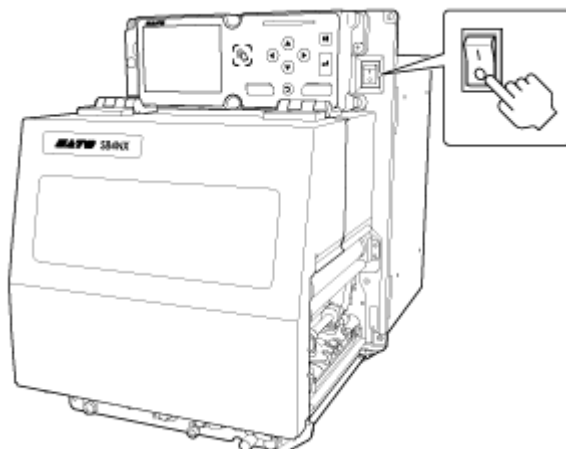





- You can power on/off the product from the main power source, from which the product takes its power, because it is equipped with a start on AC function.

To turn the power on and off from the main power source, leave the power (I/O) switch of the product in the "I" position.

---

## Initial Setup (Startup Guide)



---

The topics here explain how to complete the startup guide that appears when you power on the product for the first time after purchase.

## Startup Guide Flow

The startup guide is a function to help you through the initial product settings (language selection, date and time settings, loading the ribbon and media, etc.).

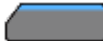
You can cancel the startup guide and perform the configuration later from the menu.

- 
- Select choices for each item with the ▲ / ▼ buttons, and apply them with the  button or  button.
  - Selecting a choice opens the next screen. To return to the previous screen, press the  button.
- 

### 1. Press the power (I/O) switch to "I" position to power on the product.

The startup guide screen appears.

### 2. Select the display language.



### 3. Select the region to set for the time zone.

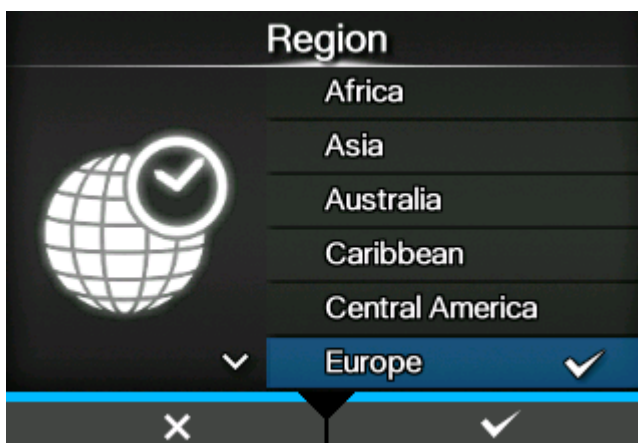

4. Select the city to set for the time zone.



5. Select the current year, month, and date.

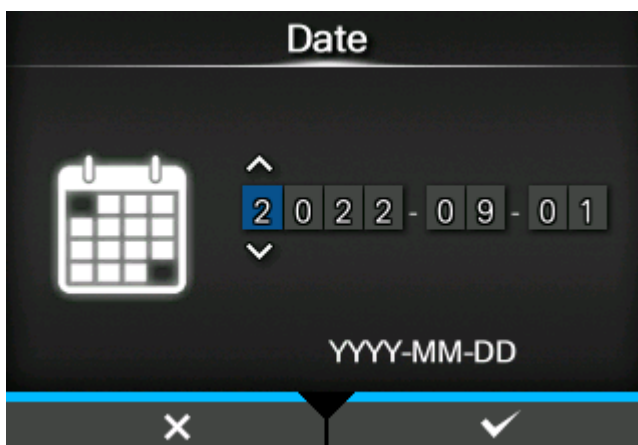

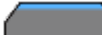
When the confirmation screen appears, press the  button to confirm the settings.

6. Select the current time.

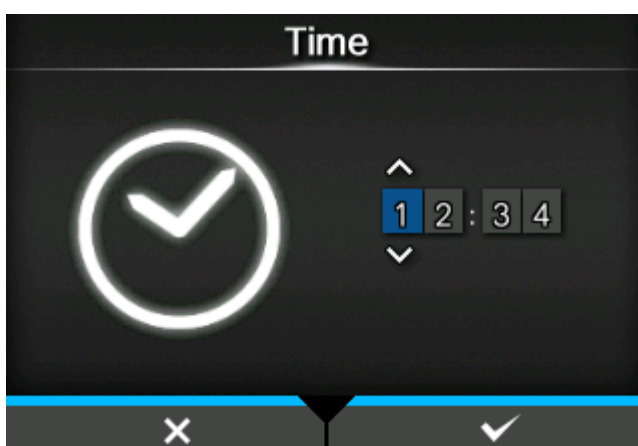

- The time is set in the 24-hour format.

When the confirmation screen appears, press the  button to confirm the settings.

**7. Select the print method to use.**

(Available only for the combined direct thermal/thermal transfer model.)

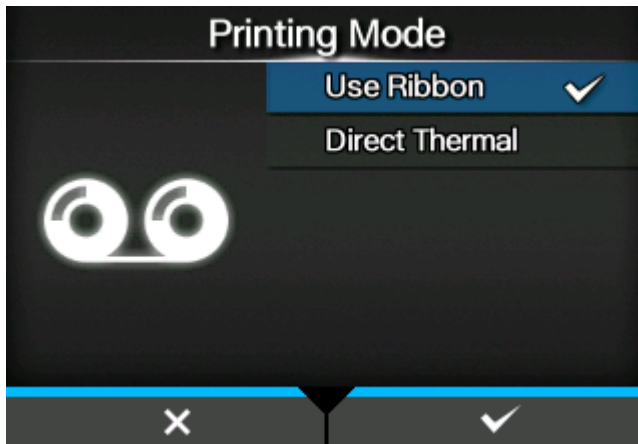

**[Use Ribbon]**

Prints using a ribbon.

**[Direct Thermal]**

Prints using direct thermal media.

**8. Load the ribbon while checking the video.**

- a. Press the  button.

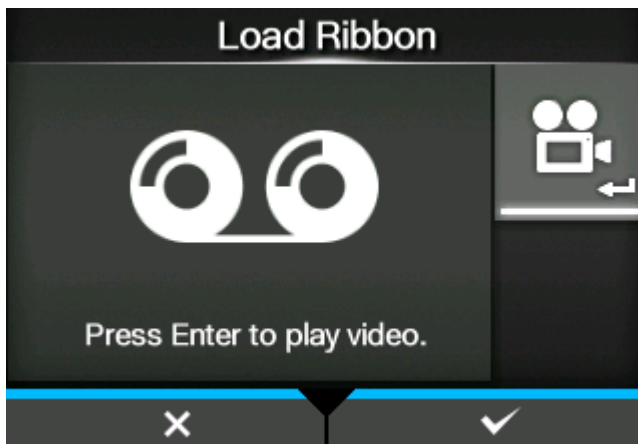

**The video starts playing.**

- b. When you have finished loading the ribbon, press the  button to stop the video.

**Returns to the screen that was open before the video played.**

- c. Press the  button.

9. Select the sensor type for detecting the media.

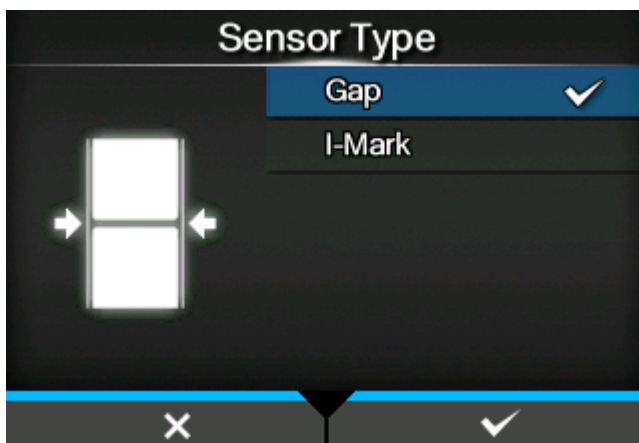

**[Gap]**

Select when using the media of Gap type. Use the transmissive sensor.

**[I-Mark]**

Select when using the media of I-mark type. Use the reflective sensor.

10. Load the media while checking the video.

- a. Press the  button.

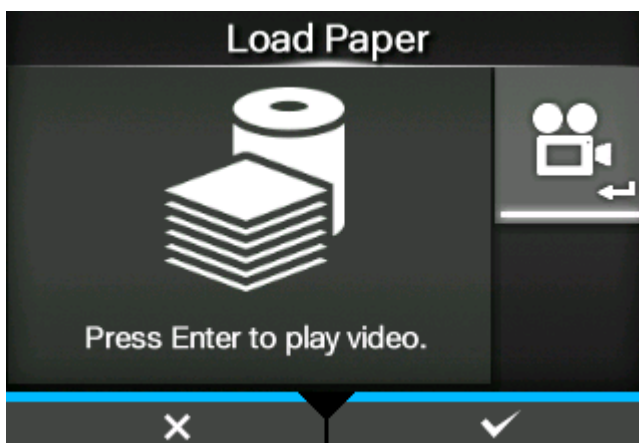

**The video starts playing.**

- b. When you have finished loading the media, press the  button to stop the video.

**Returns to the screen that was open before the video played.**

- c. Press the  button.

**The confirmation screen appears.**

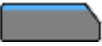
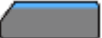
11. To show the startup guide the next time the product is started, press the  button. To not show it, press the  button.

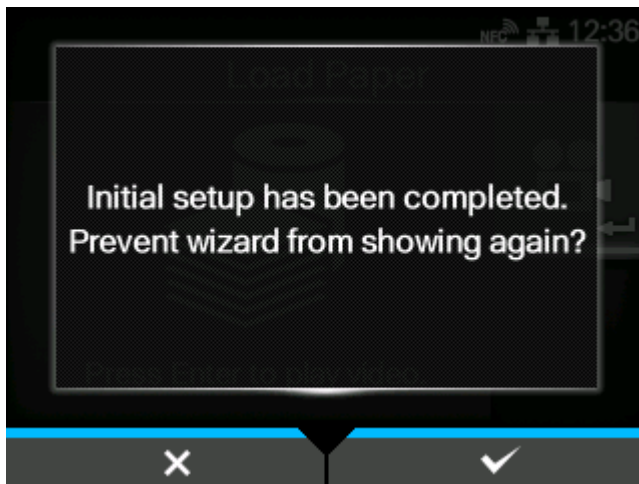

- You can set whether to open the startup guide the next time you start up the product in [Startup Guide] in the [Tools] menu.
-

## Startup Guide Cancellation

You can cancel the startup guide at any time.

1. Press the  button while configuring the startup guide.

The screen to confirm whether or not to show the startup guide again appears.

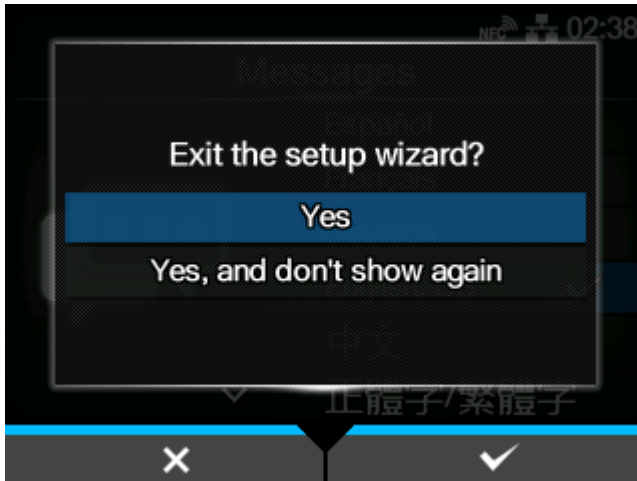

2. Select whether or not to show the startup guide during the next startup using the  /  buttons, and press the  button to confirm.

Press the  button to return to the startup guide setting without canceling it.



- You can enable or disable the startup guide in [Startup Guide] under the [Tools] menu.
  - Even if you cancel the startup guide before completing it, the product will save the settings you have changed.
-



## Manually Setting the Print Mode

---

You can change the print mode of the product according to its usage.

The product has the following print modes:

### [Continuous]

Prints the specified number of media. The media remains in position for printing at all times.

### [Dispenser]

Peels the liner from the printed label as the label is fed to the media discharge outlet. Once the printed label has been removed from the product for application, the next label will retract and position itself for printing.

### [Linerless]

When specialized hardware is installed on the external equipment, then linerless labels are fed and printed.

### [Dispense & Print]



The printed label advances to the dispensing position while the next data is printed.

If the next data is not available, it is fed to the dispensing position without printing, then backfeed and regular dispensing are done.



- In the dispense & print mode, when printing is stopped, such as due to a cancel operation during printing of labels, feed and eject the labels that have been finished printing part way before restarting printing. Restarting without doing this would cause an error.
  - When you are using the dispense & print mode, printing stops for a dispense operation, so a white void appears in the head position where printing stopped.
- 

Change the print mode according to the following procedure:

1. Press the  button or  button in Online mode.



The product changes to Offline mode.

2. Press the  button.



The product changes to Settings mode.



- Input the password if it is enabled.

3. Select [Printing] using the  /  buttons.

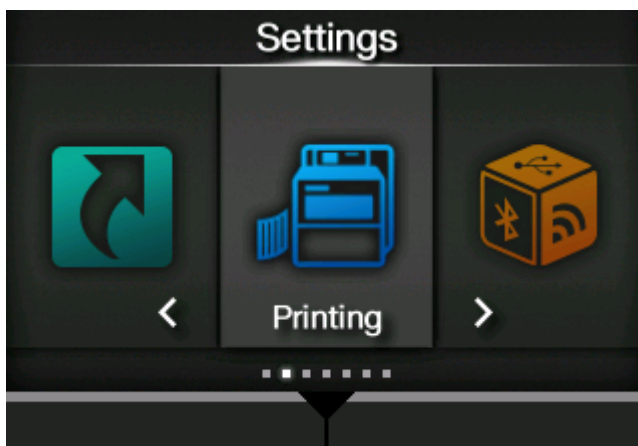

4. Press the  button.

The item list appears.

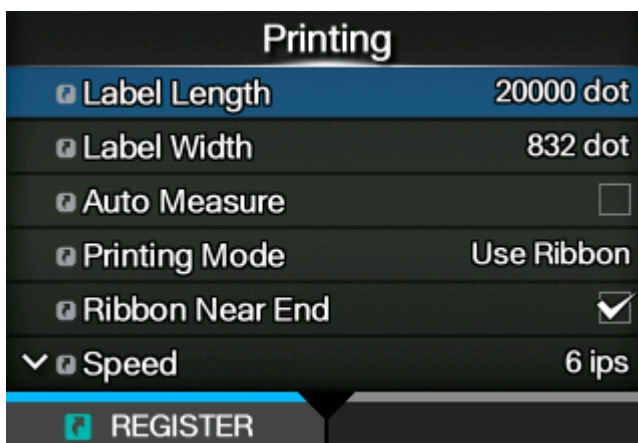

5. Select [Print Mode] using the ▲ / ▼ buttons.

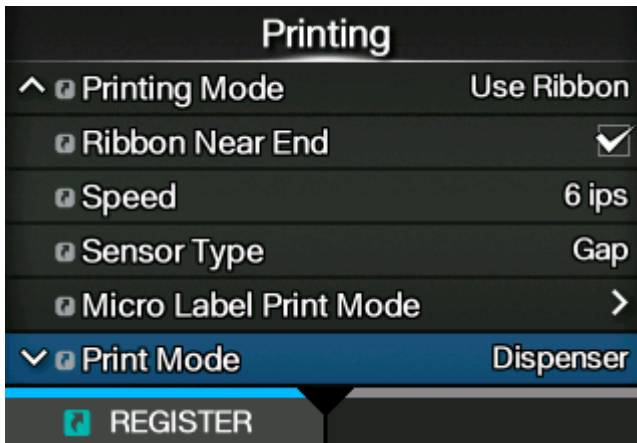

6. Press the ← button.

The [Print Mode] screen appears.

7. Select the print mode using the ▲ / ▼ buttons.

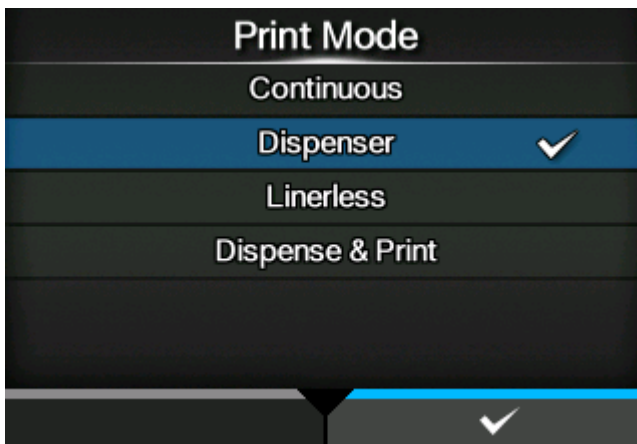

- (S84NX only) Do not select Linerless Mode to use RFID tags on an RFID model. If you set Linerless Mode, you cannot use RFID tags.

8. Press the  button to confirm.

## Connecting the Product to a Computer

---

This section explains how to connect the product to a computer, and how to install the printer driver and the All-In-One Tool.

## Procedure for Connecting the Product to a Computer

The product supports various interfaces and can be connected to a computer in an optimum way for your environment. When you have installed the printer driver to the computer, the data created with the computer (documents and illustrations) can be printed to a label through easy operations.

Also, you can print by sending a command directly to the product.

The product can be connected to a computer in the following way.

1. [Connecting Interfaces](#)



2. [Configuring the Interface Settings](#)

Set the product's interface from the Settings menu, which can be accessed from the product's display or the web configuration page.

Also, the settings can be done from the All-In-One Tool.

- When you connect them with a LAN or wireless LAN interfaces, configure the communication conditions, such as the IP address of the product.
- When you connect them with other interfaces, configure the communication conditions when needed to adapt to the computer to which you are connecting.
- To use the printer driver, the communication protocol must be set to Status4. (The initial value for the communication protocol for the product's interfaces is Status4.)



3. [Installing the Printer Driver](#) (Unnecessary when using commands)



- Use barcode fonts to create a barcode. Sometimes the barcode may not be read by a scanner if it is created with tools for creating images (such as BMP) and printed from this product. Because the tools create the barcode as an image only, the barcode may not be the correct data. Therefore, if the barcode cannot be read by a scanner, it is not a failure of the product or printer driver. Note that reading of the barcode is not guaranteed if it is created by such tools.
  - The head check is just for a reference to check a broken element of the print head, and it is not a function to guarantee barcode readability. A regular barcode reader test is required.
-

## Connecting Interfaces

### Available Interfaces

The product supports the following interfaces.



- A product connected with multiple interface cables can continue to operate when receiving data. However, you cannot receive data from more than one interface at a time. Normally, do not use multiple interfaces at a time.
- The product prints the received data in order of reception. The next received data is stored in the receive buffer while the first data is printed.

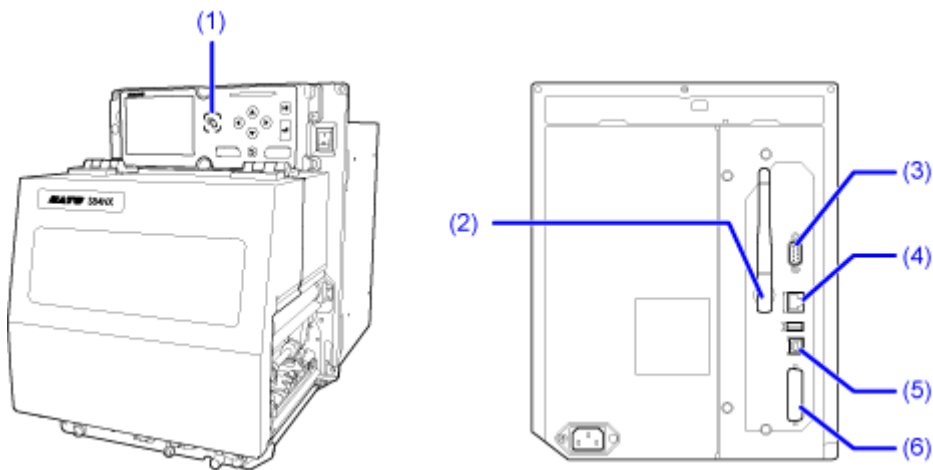

- (1) NFC
- (2) Wireless LAN
- (3) RS-232C
- (4) LAN
- (5) USB
- (6) External signal (EXT)



- The wireless LAN interface is optional.
- The NFC interface supports the handover function that simplifies the Wi-Fi connection setup with Android devices. In addition, the NFC interface can be used for changing product settings with an Android device while the product is powered off and the power cord is not connected.

## How to connect the host computer and the applicator to the product

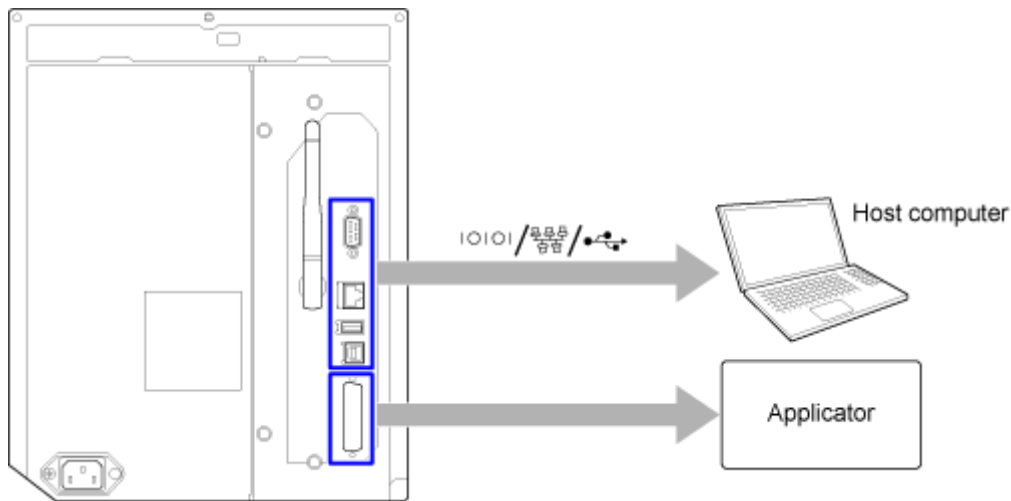

- Do not connect or disconnect the interface cables (or use a switch box) while power is supplied to either the product or computer. This may cause damage to the interface circuitry in the product or computer and is not covered by warranty.
- Check the orientation of the connector before you make the connection.

1. Make sure that the product, host computer and applicator are powered off.
  - Set the power switch of the product to the "O" position.
2. Connect the product to a host computer with one or more of the available interface connections.
3. Connect the applicator cable from the EXT connector of the product to the applicator.

### USB Interface Connection (Standard)

Connect the interface cable when the product is powered off.

Connect the USB cable to the USB connector (Type B) (1) of the product.

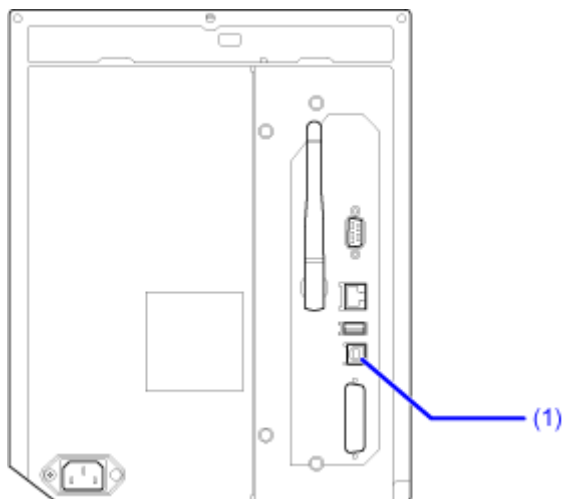

The USB interface is selected after connecting the USB cable to the computer and the product, and powering on the product while the computer is turned on.



- If the product is powered on without installing the printer driver, Windows' Plug & Play runs. When using the printer driver, do not power on the product while the USB cable is connected until instructed in the procedure for installing the printer driver.
- We recommend a USB cable that is less than 5 m (16.4 feet) long.

## LAN Interface Connection (Standard)

Connect the interface cable when the product is powered off.

Connect the LAN cable to the LAN connector (1) on the product.

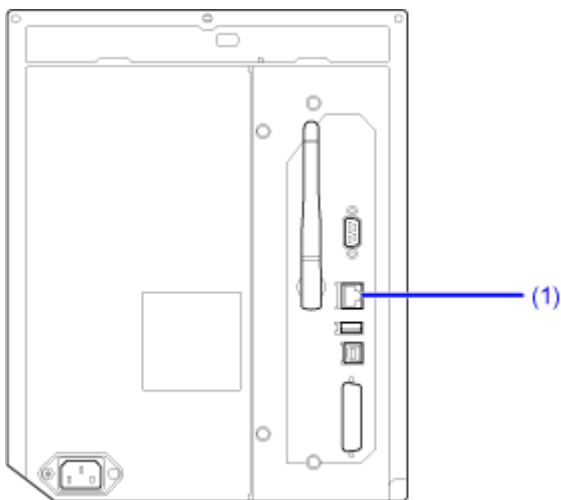

The communication condition settings must be configured according to your network environment. Set the IP address of the product.

The IP address of the product can be set through the product's [Interface] menu or the All-In-One Tool.



- To use the printer driver, the communication protocol must be set to Status4. (The initial value of the communication protocol for the product's LAN interface is Status4 ENQ.)

## NFC Interface Connection (Standard)

The NFC interface of the product supports a handover function that simplifies the Wi-Fi connection setup with Android devices.

The handover function only performs the connection setup, such as the pairing and authentication with NFC, and passes the actual interface to the more advanced Wi-Fi when communicating between NFC supported devices.

In general, the pairing and authentication require some procedures to enter authentication information, but the connection can be completed simply by holding the Android devices over the product while using NFC.

Touch the NFC antenna (1) of the product with the NFC mark on the Android device.



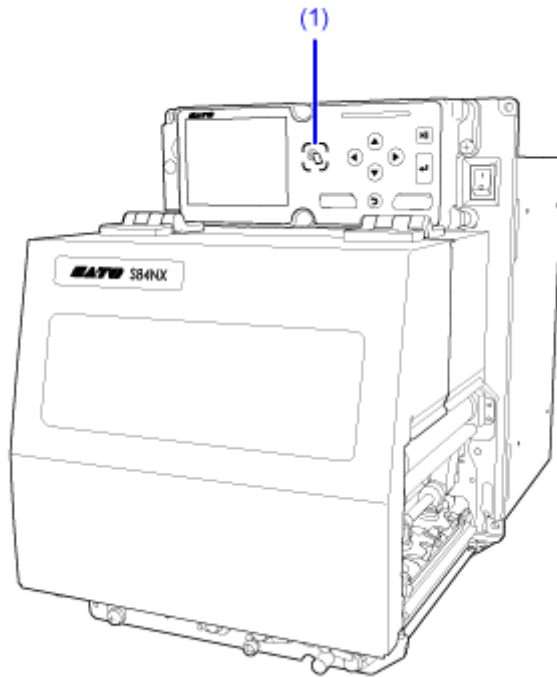

- If it does not communicate well, shift the Android device to the front, back, left and right, and then hold it up again.
- For the operation of the NFC for the Android device, refer to the user manual for the Android device.

### RS-232C Interface Connection (Standard)

Connect the interface cable when the product is powered off.

Connect the RS-232C cable to the RS-232C connector (1).

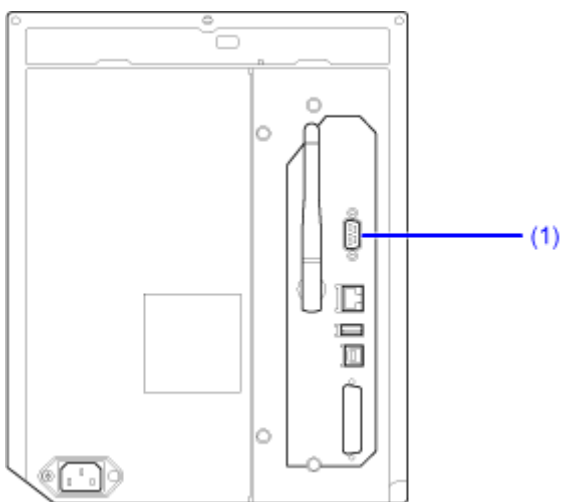

Configure the interface settings of the product according to the interface settings of the computer.

The communication conditions of the RS-232C interface can be set through the product's [Interface] menu or the All-In-One Tool.



- To use the RS-232C interface to connect with the computer, the product's [Tools] > [Barcode Checker] > [Test] > [Interface] menu must be set to [RS-232C].
- The interface settings of the computer can be confirmed by the following. In the Device Manager, right-click [Ports (COM & LPT)] > [Communications Port (COM1)] and select [Properties]. Then, check the [Port Settings] tab of the displayed Properties screen.
- For the RS-232C cable, note that the connection cable varies according to the communication protocol setting. If you use the wrong cable, it will not operate correctly.
- If the communication settings differ between the computer and product, it will not operate correctly. A communication error will be detected.
- To use the printer driver, the communication protocol must be set to Status4. (The initial value for the communication protocol for the product's RS-232C interface is Status4.)
- Be sure to use the recommended RS-232C cable.
- Printing using the USB serial conversion cable is not guaranteed. Also, no support for the connection procedure is provided.

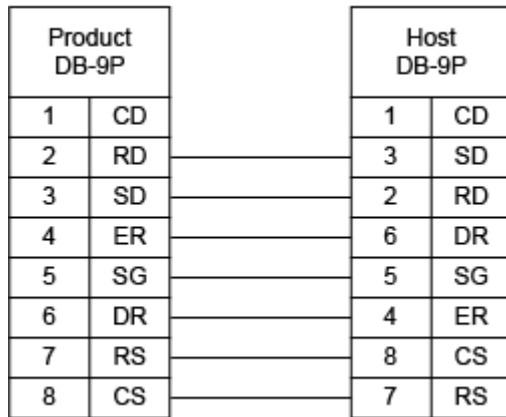

### Wireless LAN Interface Connection (Optional)

Check if the wireless LAN antenna (1) is attached to the product.

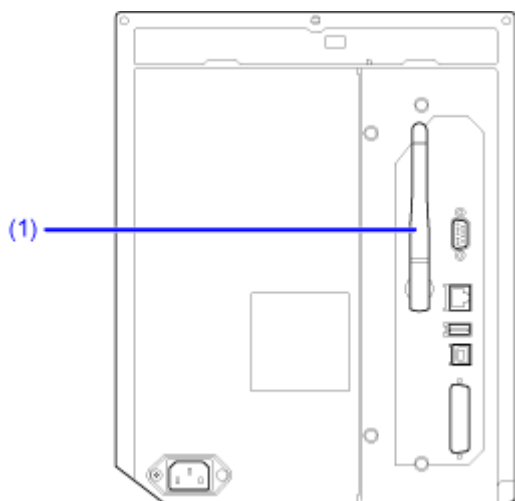

The printer driver performs data communication using the dedicated SOCKET interfaces.

The communication condition settings must be configured according to your network environment. Set the IP address of the product.

The IP address of the product can be set through the product's [Interface] menu or the All-In-One Tool.



- To use the printer driver, the communication protocol must be set to Status4. (The initial value of the communication protocol for the product's wireless LAN interface is Status4 ENQ.)
  - The product does not support Atheros, SuperG, or XR functions.
-

## Configuring the Interface Settings

### Interface Setting Methods



Configure the interface settings of the product according to the communication conditions of the connected network and computer.

You can set the interface settings of the product doing either of the following.

- Set from the Settings mode of the product
- Set using the All-In-One Tool from the computer

### Configuring the Interface Settings from the Interface Menu of the Product

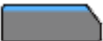
Configure the settings related to the interfaces from the [Interface] menu in the Settings mode of the product.

1. Press the  button or  button in Online mode.

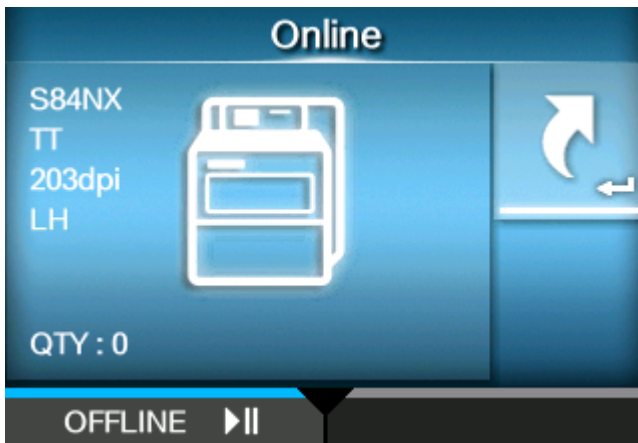

The product changes to Offline mode.

2. Press the  button.



The product changes to Settings mode.



- Input the password if it is enabled.

3. Select [Interface] using the  /  buttons.

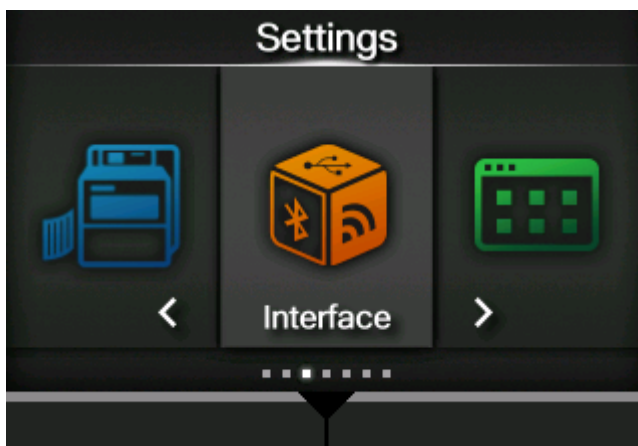

4. Press the  button.

The item list appears.

5. Select the interface using the  /  buttons.

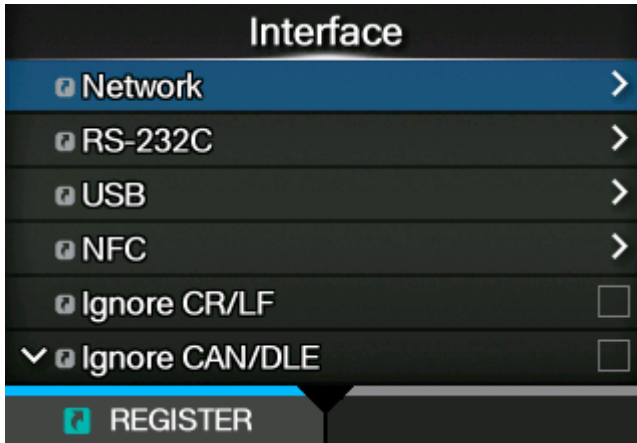

**[Network]**

Sets the LAN connection and wireless LAN connection.

**[RS-232C]**

Sets the RS-232C connection.

**[USB]**

Sets the USB connection.

**[NFC]**

Sets the NFC connection.

**[Ignore CR/LF]**

Sets to ignore CR/LF codes.

**[Ignore CAN/DLE]**

Sets to ignore CAN/DLE codes.

**[External I/O]**

Sets the external signal (EXT).

**[RFID] (S84NX only)**

Sets the RFID.

Appears only for the RFID model.

6. Press the  button.

The settings items of the selected interface appear.

Change the settings according to the communication conditions of the connected network and computer.

## Configuring the Interface Settings Using the All-In-One Tool

When you use the All-In-One Tool, you can easily set and manage the product.

Download the All-In-One Tool and All-In-One Tool Manual from your local SATO website <https://www.sato-global.com/drivers/redirect.html>, and install the software to a computer. For the compatible OS, refer to the "System Requirements" section of the All-In-One Tool Manual.

## Installing the Printer Driver

The printer driver is software that can send data created on the computer (documents and illustrations) to the product and print it to a label.

Download and use the printer driver from your local SATO website <https://www.sato-global.com/drivers/redirect.html>.

From the same site, you can download and refer to the Printer Driver Manual for details regarding how to install and the functions of the printer driver.



## All-In-One Tool Features

When you add the product to the All-In-One Tool, you can easily set and manage the product.



- For details of the All-In-One Tool, download and read the All-In-One Tool Manual from your local SATO website. <https://www.sato-global.com/drivers/redirect.html>
-

---

# Loading Media and Ribbon

---

## Media, Ribbon and Print Methods

---

The product is available in two models, the direct thermal model and the combined direct thermal/thermal transfer model.

The media or ribbon to be used varies depending on the print method.

**Thermal transfer (combined direct thermal/thermal transfer model only)**

Prints using a ribbon.

**Direct thermal**

Prints using direct thermal media.



- Ribbon is not necessary if you are using direct thermal media.
-

# Loading Media

## Usable Media

The product can print on a media roll.

The product uses media sensors to detect I-marks or gaps on the media in order to precisely print the content.

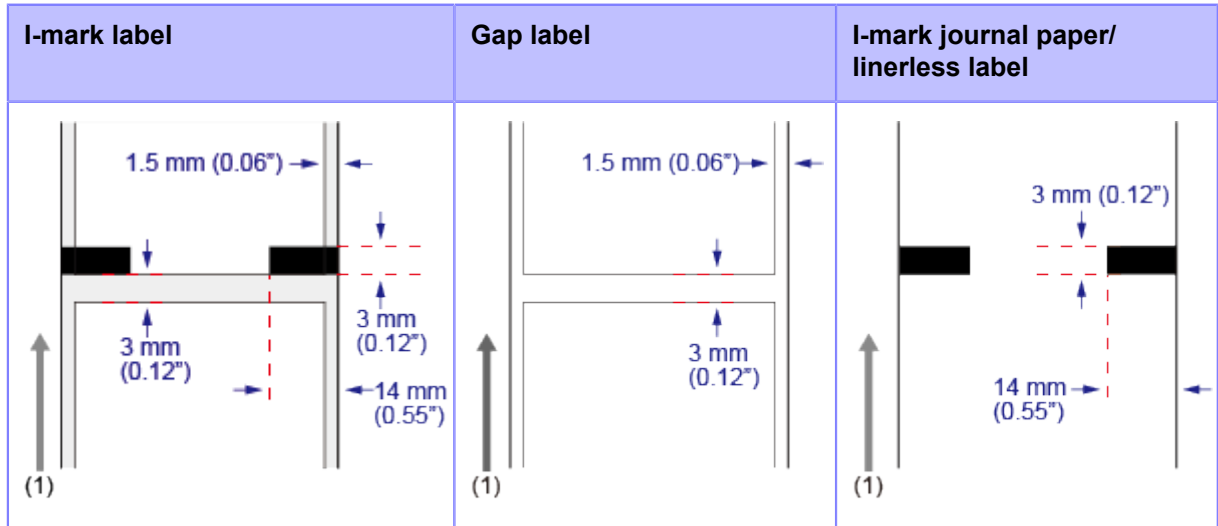

(1) Media feed direction

## Adjusting the Position of the Media Sensor

When you use nonstandard media (for example, media with printing on the underside, or media with a special shape), the media sensor cannot detect the I-mark or gap of the media correctly. In such cases, make sure that the media sensor position is aligned with the I-mark or gap of the media.

The I-mark sensor of the product has a fixed position of 5 mm (0.2") measured from the product's center frame.

The position of the Gap sensor is adjustable. You can adjust the Gap sensor position in the following range.

S84NX: 5 to 66 mm (0.2" to 2.6") measured from the product's center frame.

S86NX: 5 to 81 mm (0.2" to 3.2") measured from the product's center frame.

1. **Open the top cover.**
2. **Turn the media sensor adjustment knob (1) clockwise or counterclockwise to adjust the Gap sensor position.**

The green indicator (2) on top of the media sensor assembly shows the position of the Gap sensor.

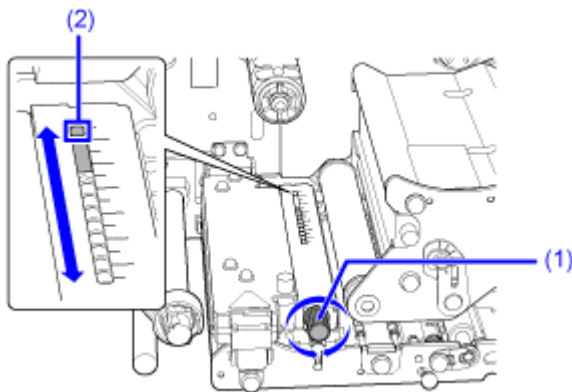

## Winding Direction of the Media

The media either winds face-out or face-in. Load the media with the print side facing up.

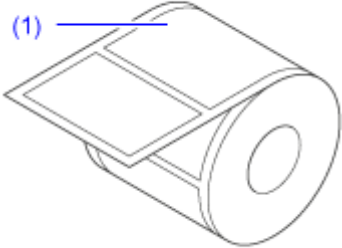
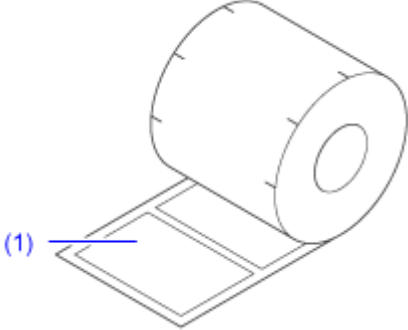
Face-out	Face-in
<p data-bbox="244 472 810 506">The print side faces the outer side of the media.</p>  <p>The diagram shows a roll of media with a sheet partially unrolled. A blue line labeled '(1)' points to the outer surface of the unrolled sheet, indicating that the print side is facing outwards.</p>	<p data-bbox="849 472 1415 506">The print side faces the inner side of the media.</p>  <p>The diagram shows a roll of media with a sheet partially unrolled. A blue line labeled '(1)' points to the inner surface of the unrolled sheet, indicating that the print side is facing inwards.</p>

(1) Print side

## Precautions for Loading the Media

Use our specified supply products for the product, for optimum print quality.



- The print head and its surroundings are hot after printing. Be careful not to get burned.
  - Touching the edge of the print head with your bare hand could cause injury.
- 



- The usable media sizes and print quality depends conditions such as print speed, media, media/ribbon combination, product settings and used environment. It is highly recommended to check the performance based on actual usage conditions in advance.
-

## Loading Media with Dispenser

The below topic describes the procedure to dispense the label and eject the liner out of the product.



- The routing path of the media is shown in the below picture.

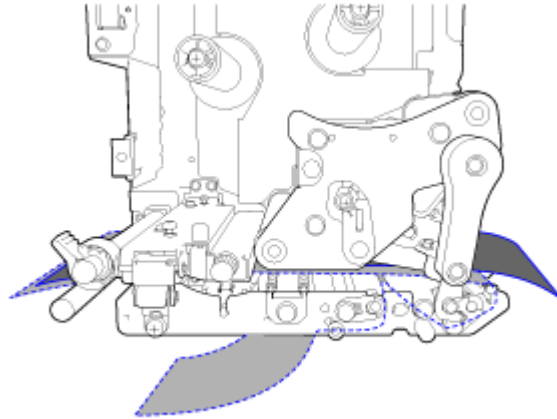

Label



Liner

### 1. Open the top cover (1).



- Open the top cover fully to prevent accidental drop of the cover.

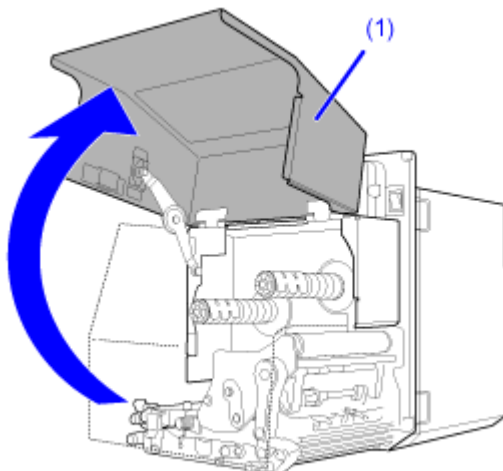

2. Turn the head lock lever (2) clockwise to unlock the print head.

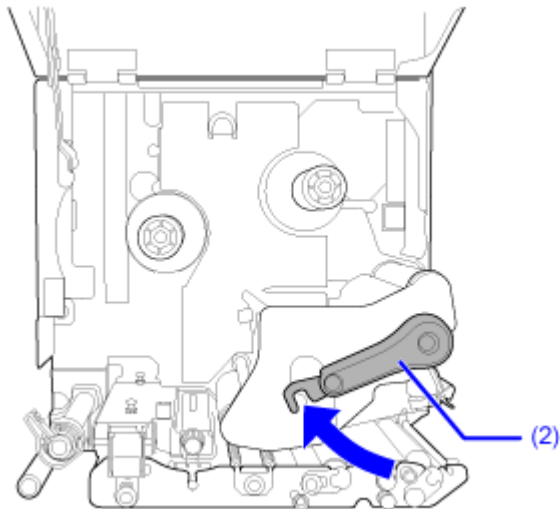

3. Pull the feed lock latch (3) to unlock the feed roller and media sensor assembly.  
The feed roller and media sensor assembly (4) will flip open.

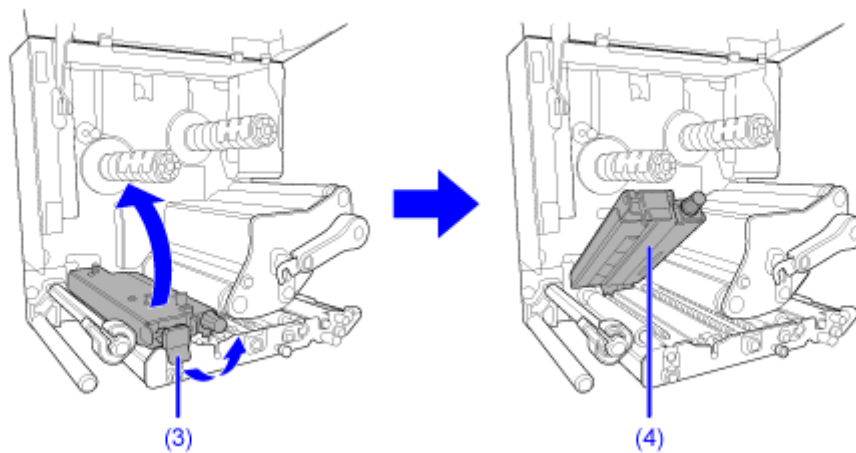

4. Pull the media guide (5) away from the product.

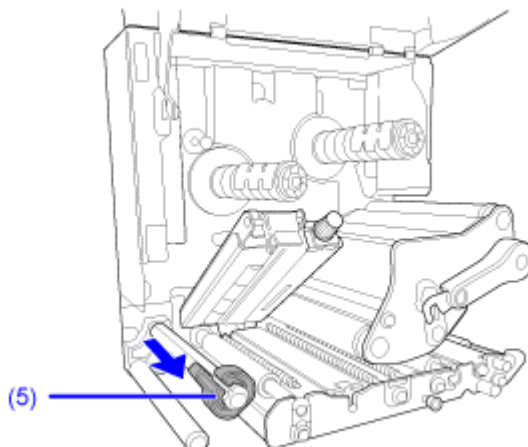



5. Pass the media between the media shaft (6), below the feed roller and media sensor assembly (4), and the print head assembly (7) and extend it out the discharge outlet (8).

Make sure that the end of the media extends out the discharge outlet.

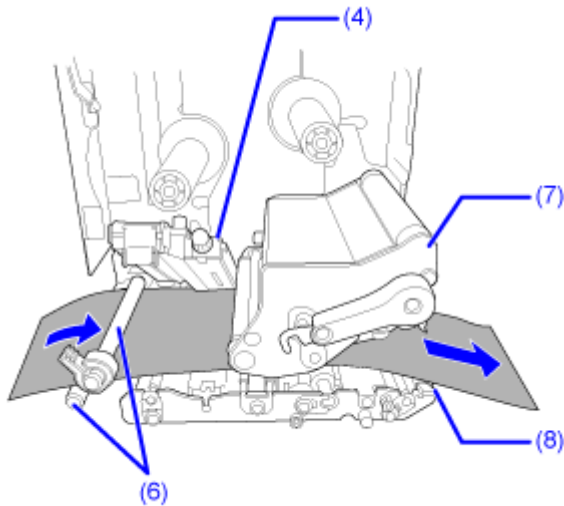

6. Push the media until the innermost edge of the media lightly touches the product's center frame (1), and then push the media guide (5) lightly against the outermost edge of the media (2).

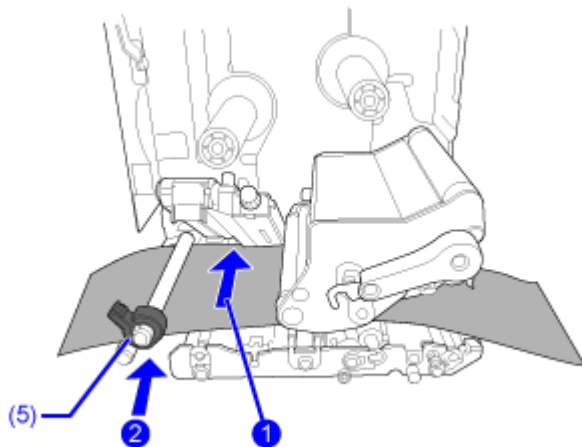

7. Pull the label out from the discharge outlet and remove about 30 cm (11.8") of labels (9) from the liner (10).

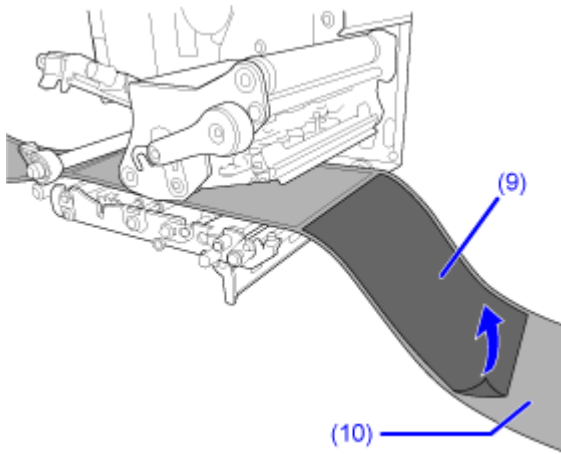

8. Push the tab (11) up to release the pressure plate (12).

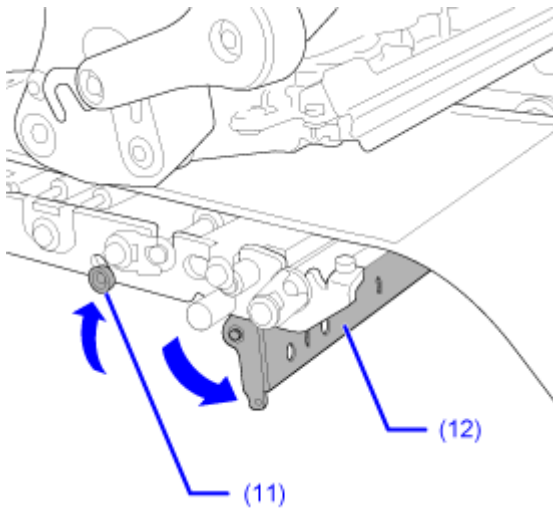

9. Pass the liner (10) through the gap of the pressure plate (12).

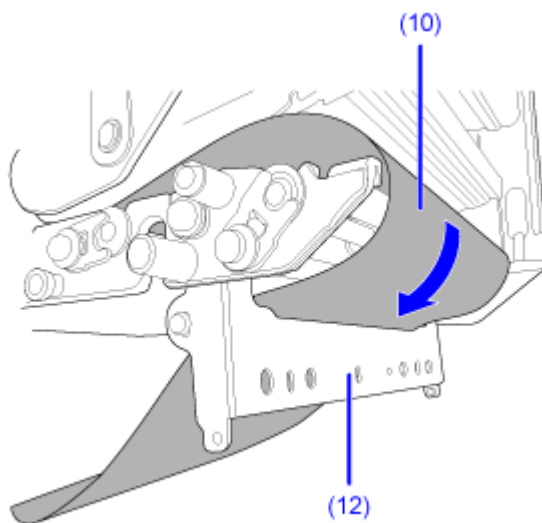

10. Turn the head lock lever (2) counterclockwise to lock the print head (1), and then press the feed roller and media sensor assembly (4) down until the feed lock latch (3) is locked (2).

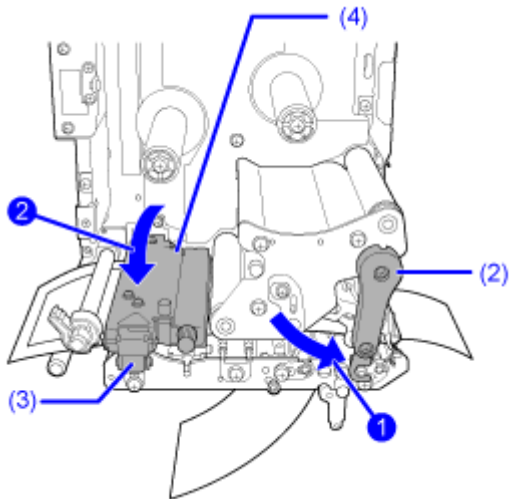

11. Pull the liner (10) lightly so that the media does not sag.

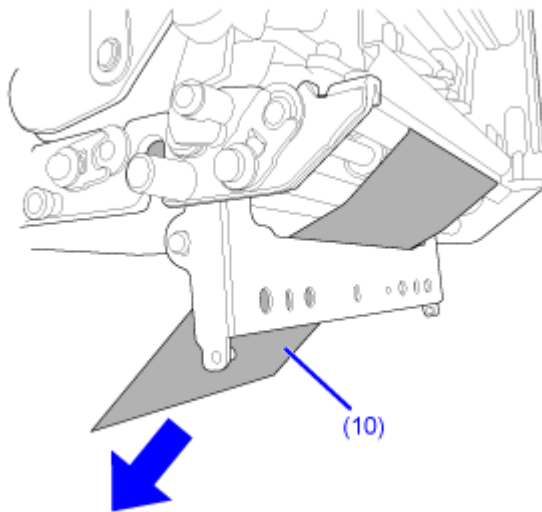

**12. Push the center of the pressure plate (12) to latch it in place.**

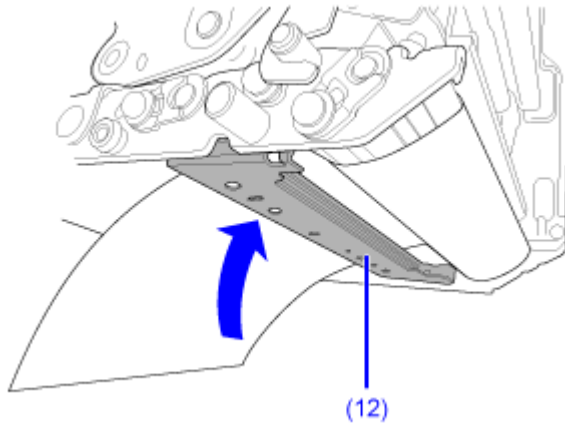



**13. Close the top cover.**

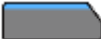

- When closing the top cover, be careful not to pinch your fingers.
- 

**14. Press the  button (FEED) in Offline mode to feed the media.**

**15. Press the  button (ONLINE) or  button to change to Online mode.**



- You need to load the ribbon when printing using thermal transfer.
-

## Loading Media without Using Dispenser

The below topic describes the procedure to just load the media without using the dispenser.

---



- The routing path of the media is shown in the below picture.

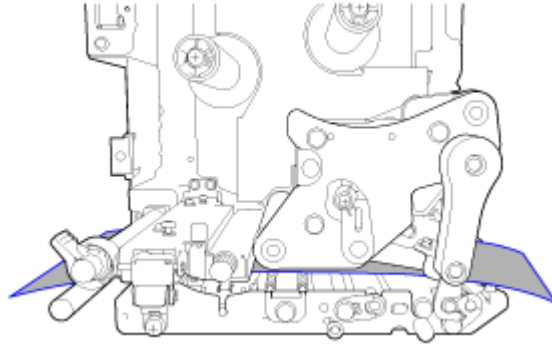

---

### 1. Open the top cover (1).



- Open the top cover fully to prevent accidental drop of the cover.
- 

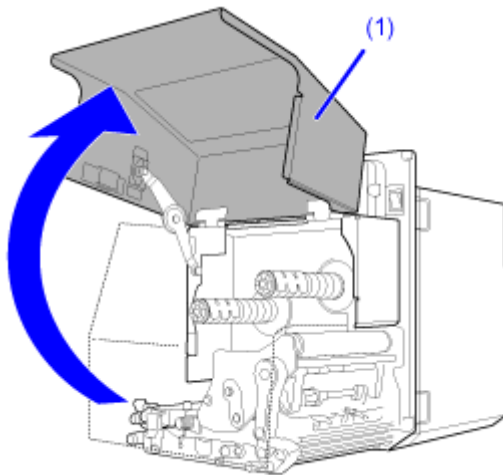

2. Turn the head lock lever (2) clockwise to unlock the print head.

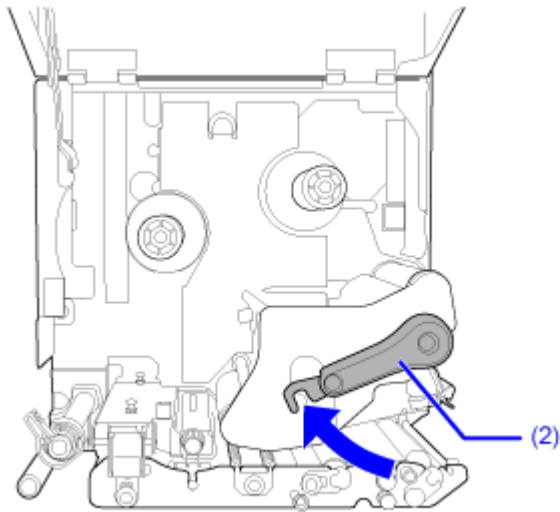

3. Pull the feed lock latch (3) to unlock the feed roller and media sensor assembly.  
The feed roller and media sensor assembly (4) will flip open.

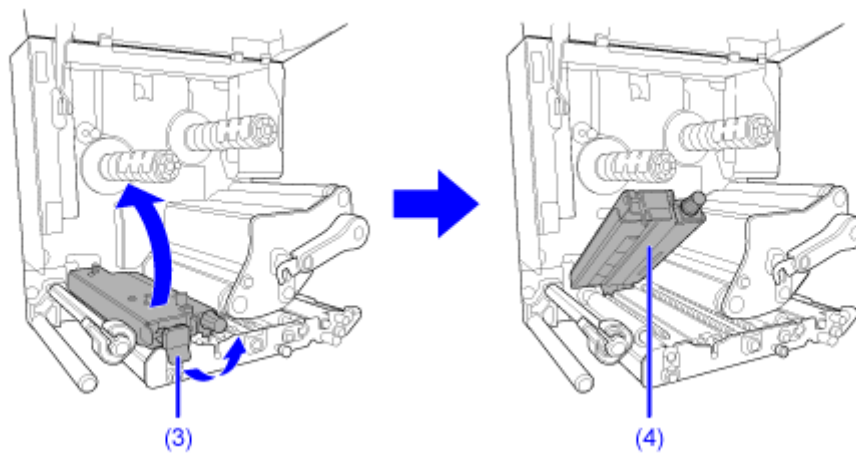

4. Pull the media guide (5) away from the product.

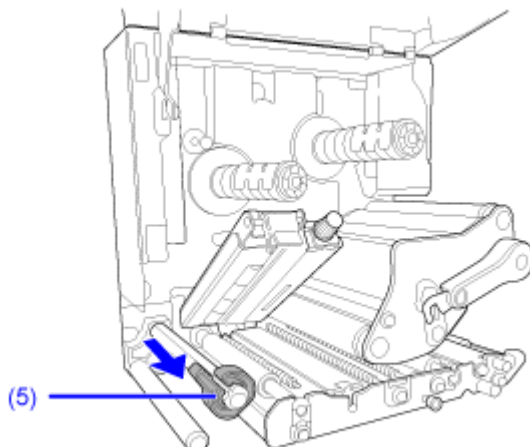

5. Pass the media between the media shaft (6), below the feed roller and media sensor assembly (4), and the print head assembly (7) and extend it out the discharge outlet (8).

Make sure that the end of the media extends out the discharge outlet.

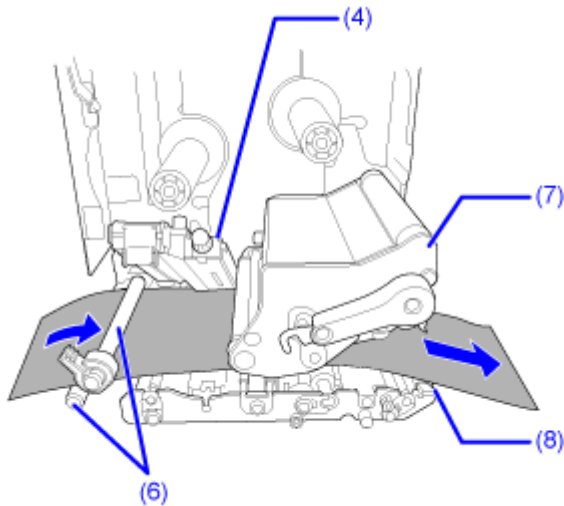

6. Push the media until the innermost edge of the media lightly touches the product's center frame ①, and then push the media guide (5) lightly against the outermost edge of the media ②.

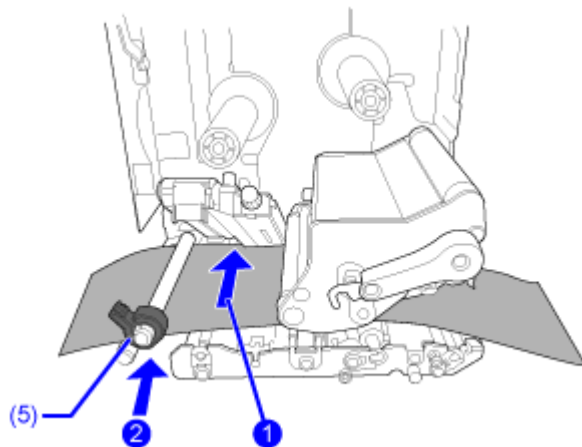

7. Turn the head lock lever (2) counterclockwise to lock the print head (1), and then press the feed roller and media sensor assembly (4) down until the feed lock latch (3) is locked (2).

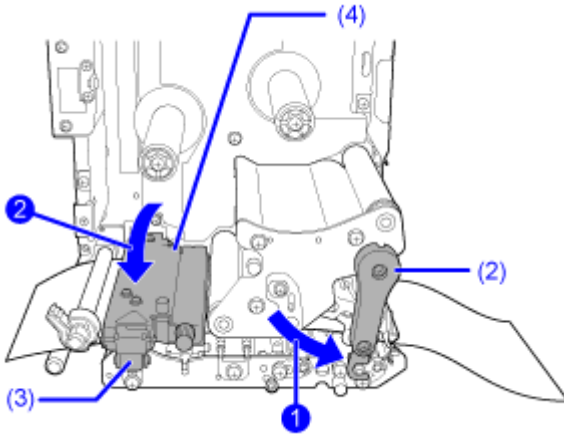



8. Close the top cover.



- When closing the top cover, be careful not to pinch your fingers.

9. Press the  button (FEED) in Offline mode to feed the media.

10. Press the  button (ONLINE) or  button to change to Online mode.



- You need to load the ribbon when printing using thermal transfer.



## Loading Ribbon (Thermal Transfer Only)

---

You need to load the ribbon when printing using thermal transfer. The topics here explain how to load and replace the ribbon.

## Checking the Ink Side of the Ribbon

There are two winding directions for the ribbon. Face-out means the ink is on the outer side and Face-in means the ink is on the inner side. The product supports both winding directions. You can examine the ink side of the ribbon using the following procedure.

1. Place the ribbon so the outer side is down and spreads out.

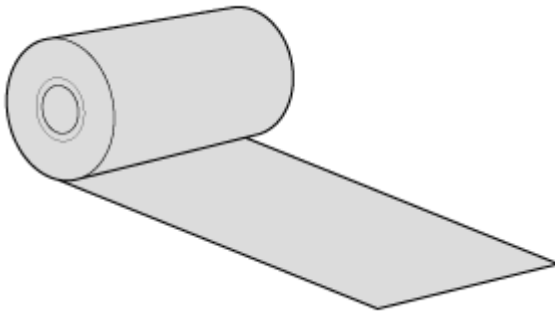

2. Apply adhesive tape to the inner side of the ribbon, and press it lightly.

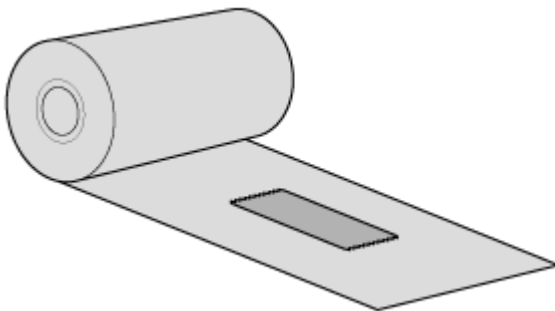

3. Peel off the adhesive tape.

If there is ink on the adhesive tape, then that ribbon has a coating of ink on the inner side.

- The ink is coated on the outer side. (Face-out ribbon)

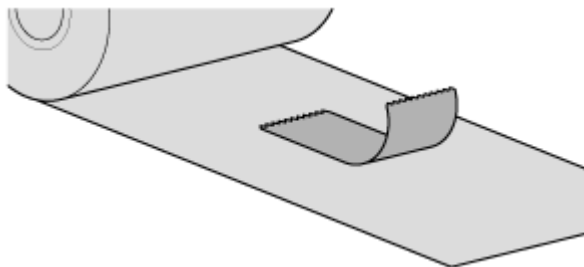

- The ink is coated on the inner side. (Face-in ribbon)

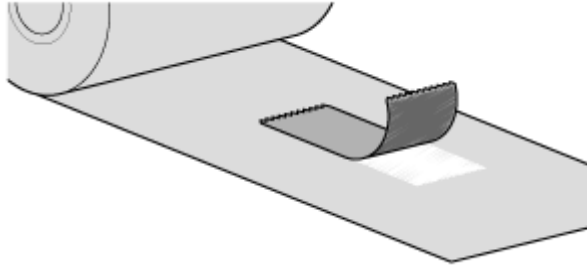

## Loading the Ribbon



- The print head and its surroundings are hot after printing. Be careful not to get burned.
  - Touching the edge of the print head with your bare hand could cause injury.
- 



- Use genuine SATO media and ribbons for the product, for optimum print quality.
- The routing path of the ribbon is shown in the below picture.

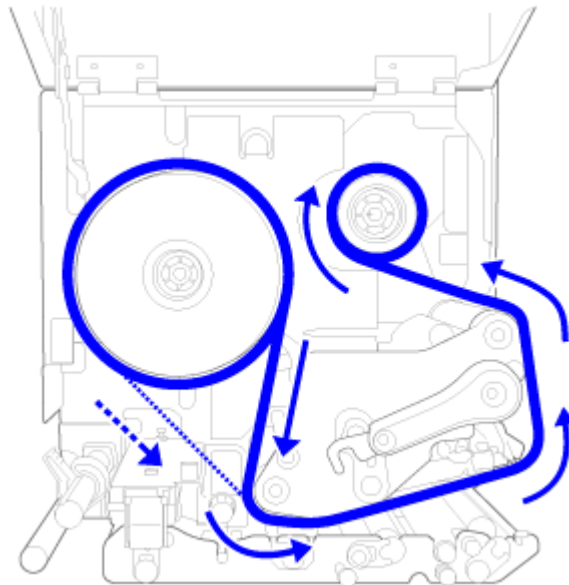

Face-in ribbon



Face-out ribbon

- You can also refer to the sticker located on the inner side of the top cover.
- 

### 1. Open the top cover (1).



- Open the top cover fully to prevent accidental drop of the cover.
- 

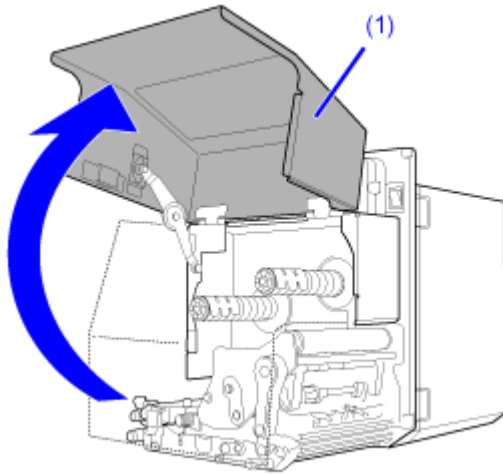

2. Turn the head lock lever (2) clockwise to unlock the print head.

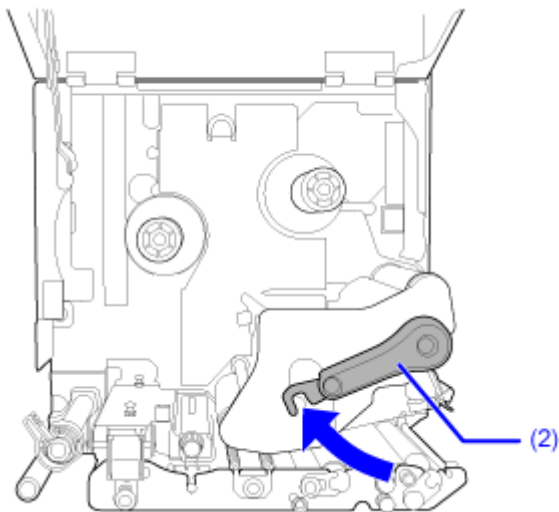

**3. Load an empty ribbon core (3) onto the ribbon rewind spindle (4).**

Insert the core all the way in.

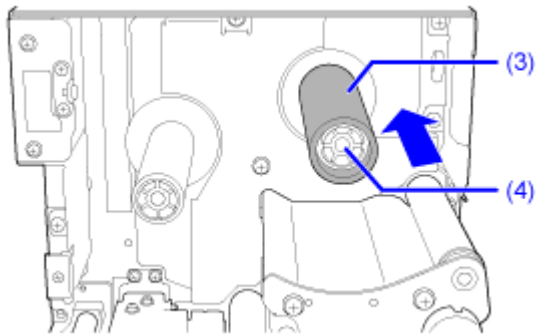

If there is any ribbon on the ribbon rewind spindle, remove it from the spindle before installing new ribbon.

**4. Load the ribbon (5) onto the ribbon supply spindle (6).**

While taking note of the winding direction, insert the ribbon all the way in.

Make sure that the ink side of the ribbon is facing down when passing it below the print head.

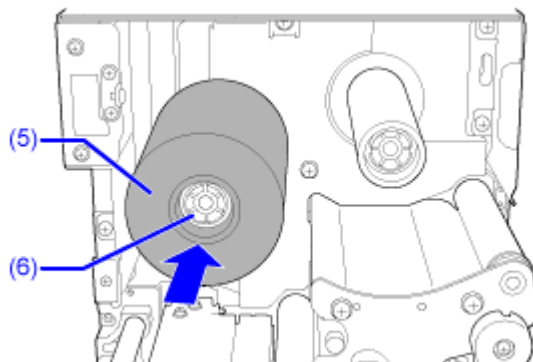

5. From the ribbon supply spindle (6), pass the ribbon below the print head (7) and to the ribbon rewind spindle (4).

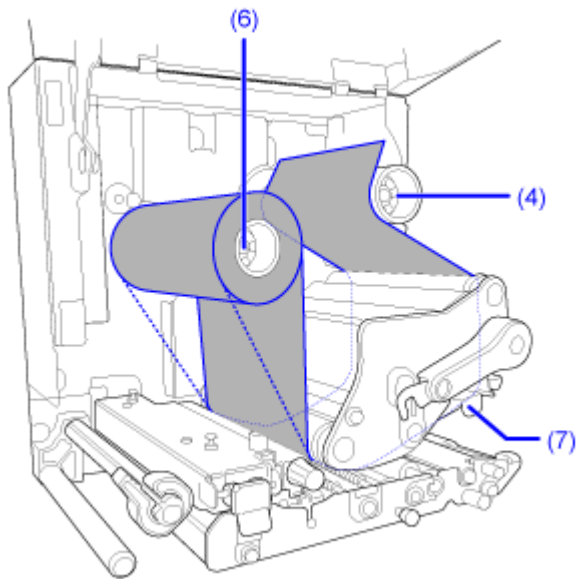

- Face-in ribbon
- - - Face-out ribbon

6. Wind the ribbon clockwise around the empty ribbon core and attach the free end of the ribbon to the ribbon core with adhesive tape (8).

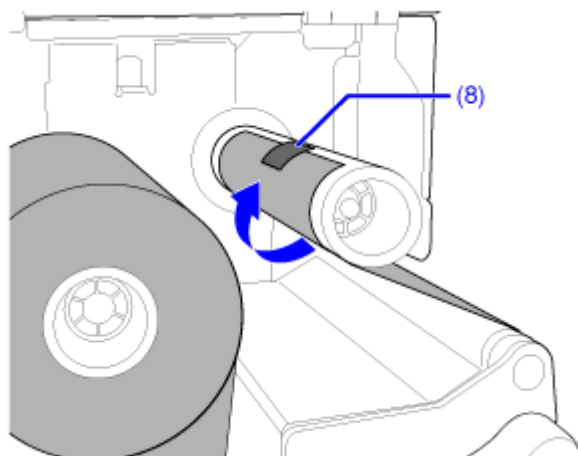

7. Turn the ribbon rewind spindle (4) clockwise for several rounds to wind the ribbon while removing the slack from the ribbon.

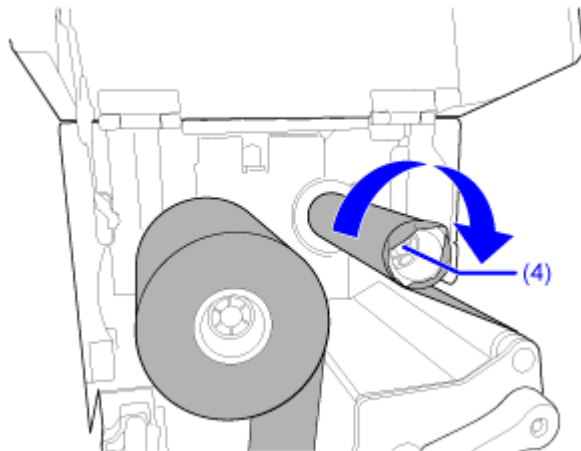

8. If the media is already loaded, turn the head lock lever (2) counterclockwise to lock the print head.

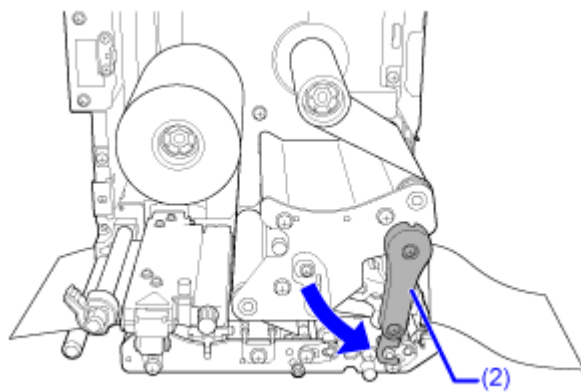

9. Close the top cover.



- When closing the top cover, be careful not to pinch your fingers.
-



## Replacing the Ribbon

### 1. Open the top cover (1).



- Open the top cover fully to prevent accidental drop of the cover.

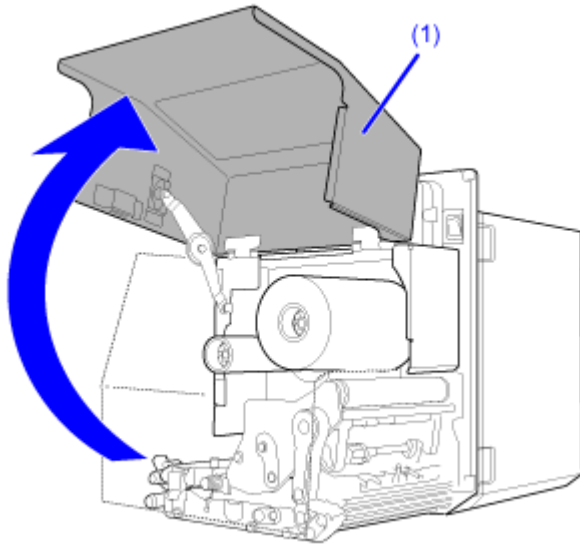

### 2. Turn the head lock lever (2) clockwise to unlock the print head.

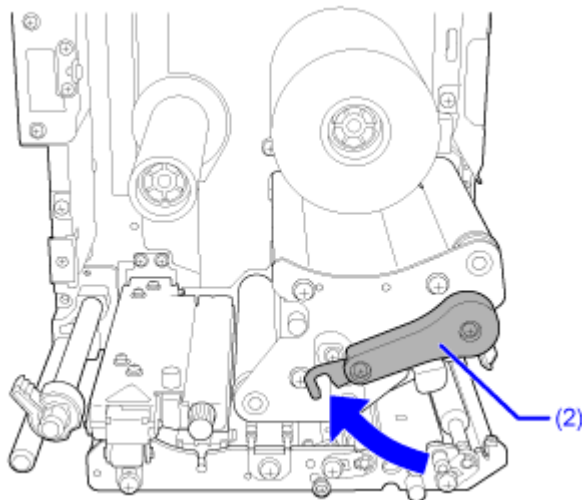

3. Pull to remove the used ribbon from the ribbon rewind spindle (3).

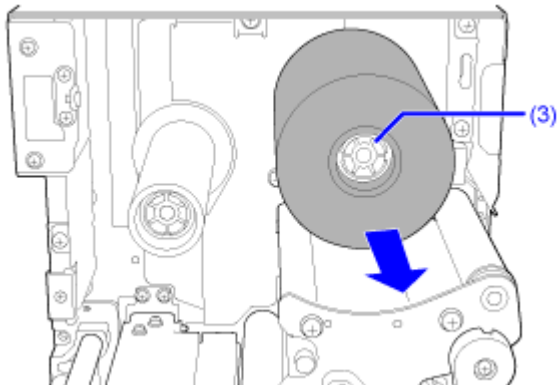

4. Pull to remove the empty core from the ribbon supply spindle (4).

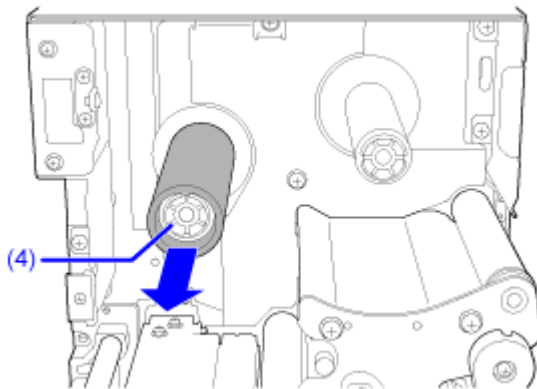

5. Load an empty ribbon core (5) onto the ribbon rewind spindle (3).

Insert the core all the way in.

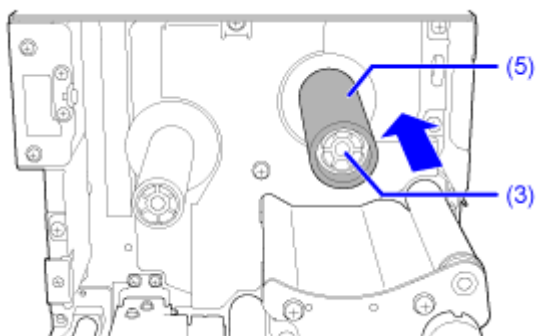

**6. Load the ribbon (6) onto the ribbon supply spindle (4).**

While taking note of the winding direction, insert the ribbon all the way in.

Make sure that the ink side of the ribbon is facing down when passing it below the print head.

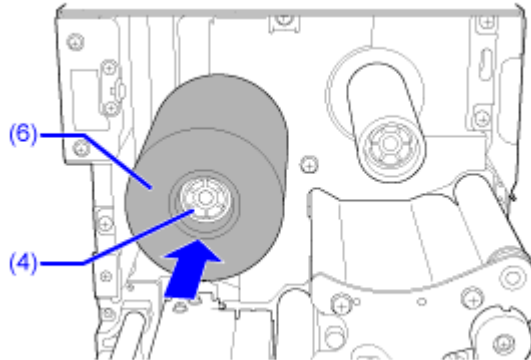

**7. From the ribbon supply spindle (4), pass the ribbon below the print head (7) and to the ribbon rewind spindle (3).**

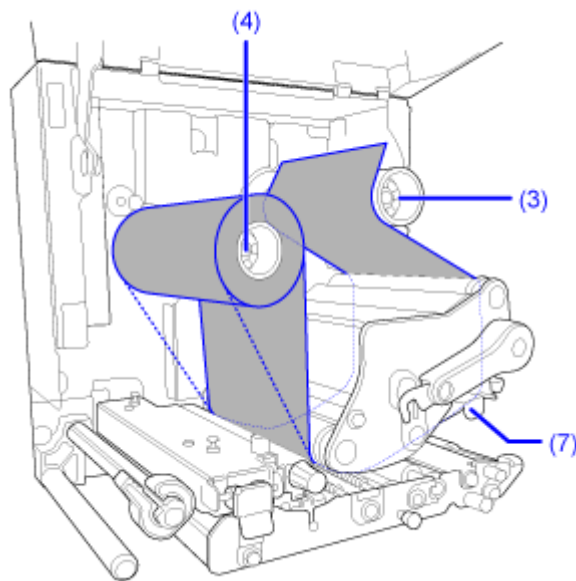

Face-in ribbon



Face-out ribbon

8. Wind the ribbon clockwise around the empty ribbon core and attach the free end of the ribbon to the ribbon core with adhesive tape (8).

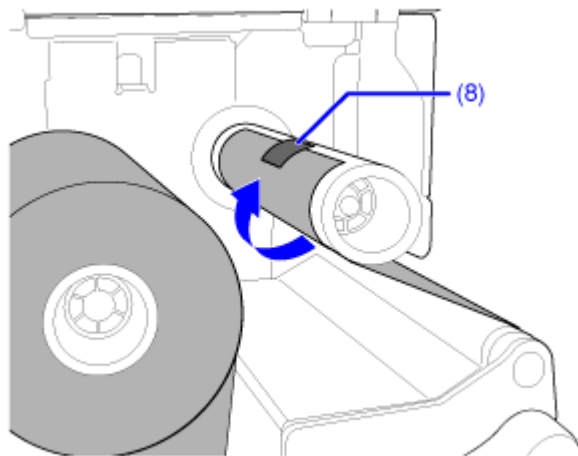

9. Turn the ribbon rewind spindle (3) clockwise for several rounds to wind the ribbon while removing the slack from the ribbon.

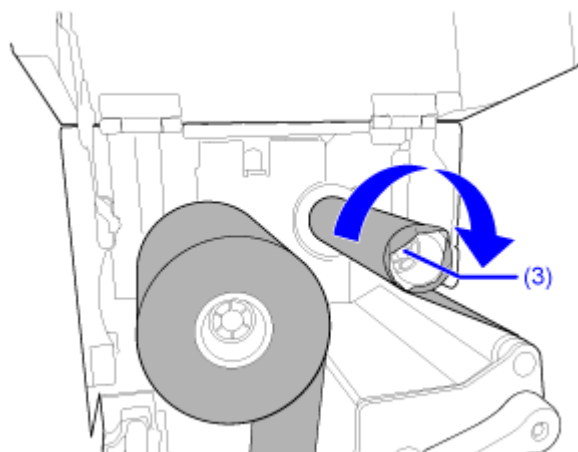

10. If the media is already loaded, turn the head lock lever (2) counterclockwise to lock the print head.

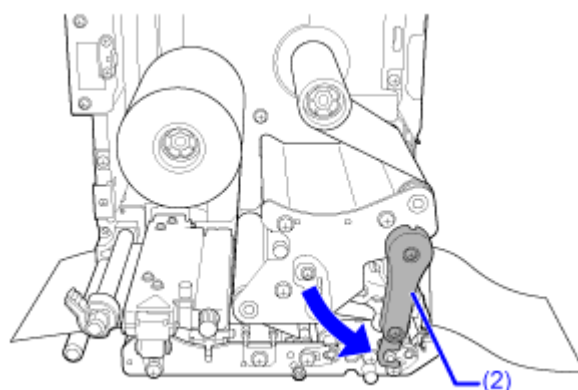



11. Close the top cover.



- When closing the top cover, be careful not to pinch your fingers.
- 

12. Press the  button (FEED) in Offline mode to feed the media.

13. Press the  button (ONLINE) or  button to change to Online mode.

## Settings to Match the Media

---

### Print Method (Combined Direct Thermal/Thermal Transfer Model Only)

For the combined direct thermal/thermal transfer model, you can select from two types of print methods.

#### Thermal transfer

Prints using a ribbon.

#### Direct thermal

Prints using direct thermal media.



- Ribbon is not necessary if you are using direct thermal media.
- 

You can set the print method by using the startup guide. Alternatively, the following procedure can be used.

1. Press the  button or  button in Online mode.



The product changes to Offline mode.

2. Press the  button.



The product changes to Settings mode.



- Input the password if it is enabled.

3. Select [Printing] using the  /  buttons.

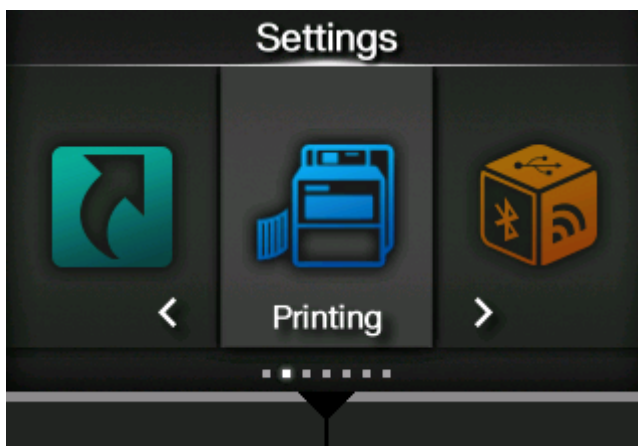

4. Press the  button.

The item list appears.

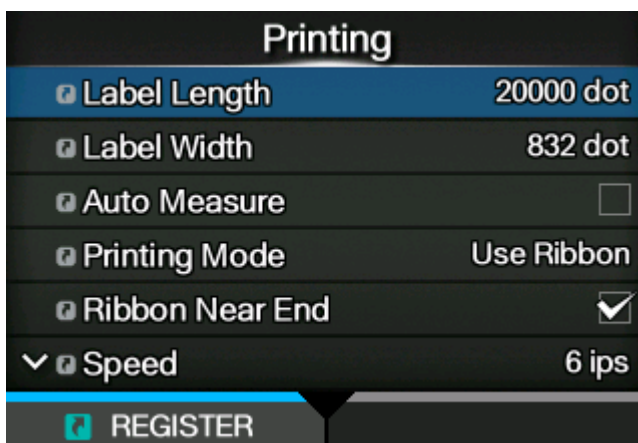

5. Select [Printing Mode] using the ▲ / ▼ buttons.

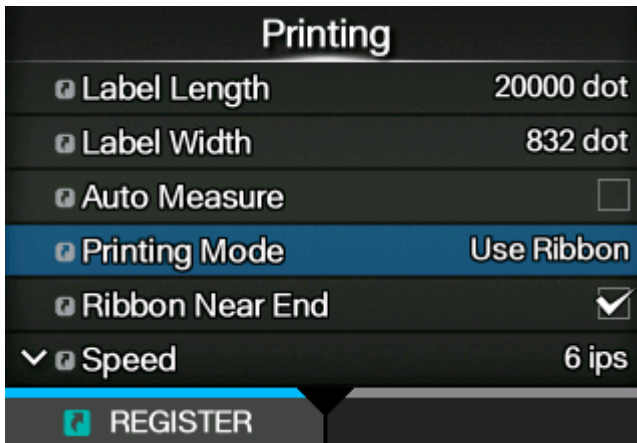

6. Press the ← button.

The [Printing Mode] screen appears.

7. Select the print method using the ▲ / ▼ buttons.



**[Use Ribbon]**

Prints using a ribbon.

**[Direct Thermal]**

Prints using direct thermal media.

8. Press the [confirm] button to confirm.



## Media Sensor Type

The product adjusts the print position precisely by detecting I-marks or gaps on the media (label) using media sensors.

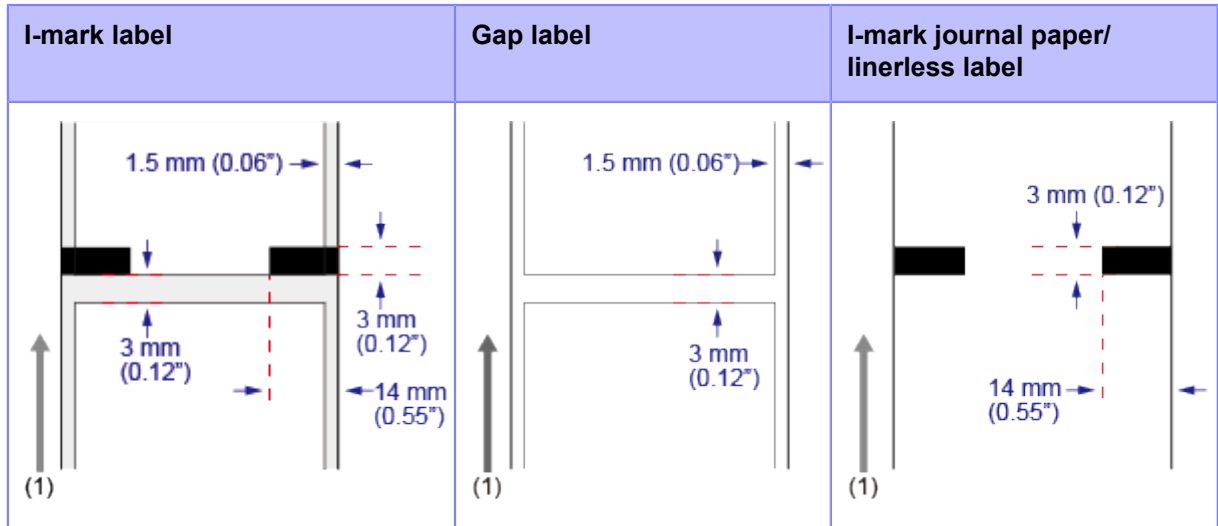

The I-marks or gaps on each type of media are as follows:



(1) Media feed direction

Set the sensor type to detect the print position according to the media to be used.

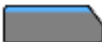
You can set the sensor type by using the startup guide. Alternatively, the following procedure can be used.

1. Press the  button or  button in Online mode.



The product changes to Offline mode.

2. Press the  button.



The product changes to Settings mode.



- Input the password if it is enabled.

3. Select [Printing] using the  /  buttons.

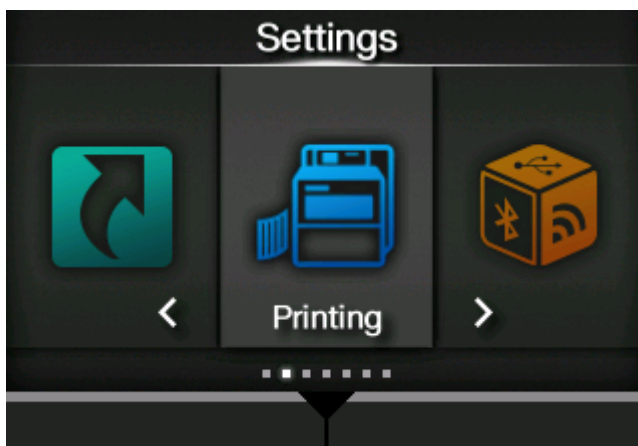

4. Press the  button.

The item list appears.

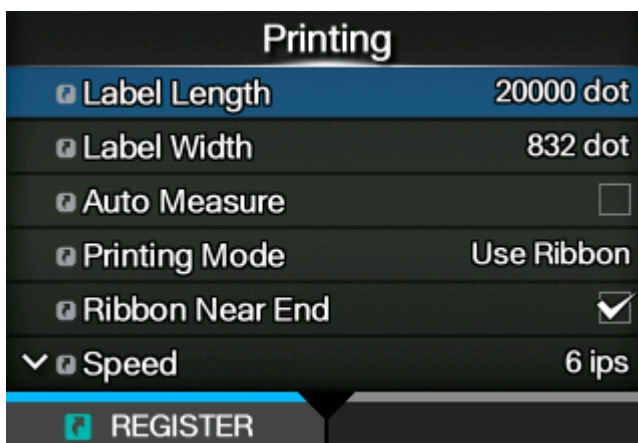

5. Select [Sensor Type] using the ▲ / ▼ buttons.

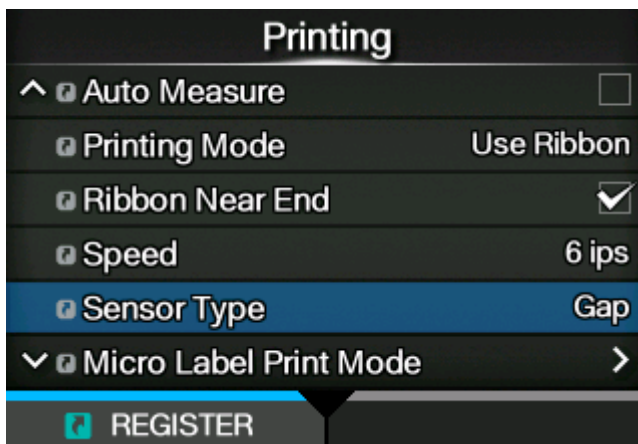

6. Press the ← button.

The [Sensor Type] screen appears.

7. Select the sensor type to detect the print position using the ▲ / ▼ buttons.

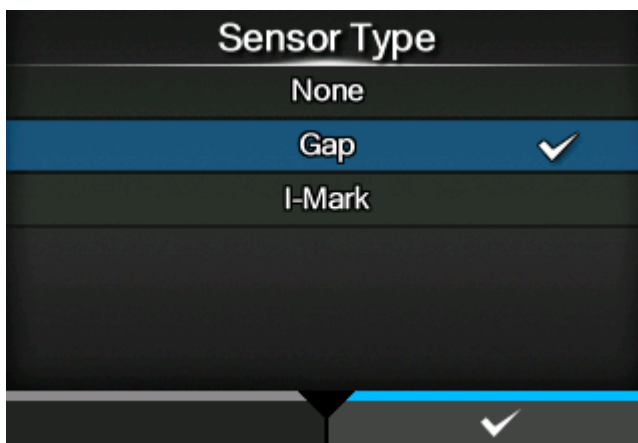

**[None]**

Disables the media sensor.

**[Gap]**

Select when using gap type media. Use the transmissive type sensor.

**[I-Mark]**

Select when using I-mark type media. Use the reflective type sensor.



- If you have selected [Dispenser] or [Dispense & Print] in the [Print Mode] menu, only [Gap] and [I-Mark] will be available.
- If you have selected [Linerless] in the [Print Mode] menu, only [None] will be available.

8. Press the  button to confirm.

## When to Replace Media and Ribbon

---

### Checking the Remaining Amount of Media and Ribbon

You can check the remaining amount of media and ribbon according to the following procedure.

- **Checking through the window on the front side of the product**

You can visually check the remaining amount of ribbon in the product through the window on the front of the product (1).

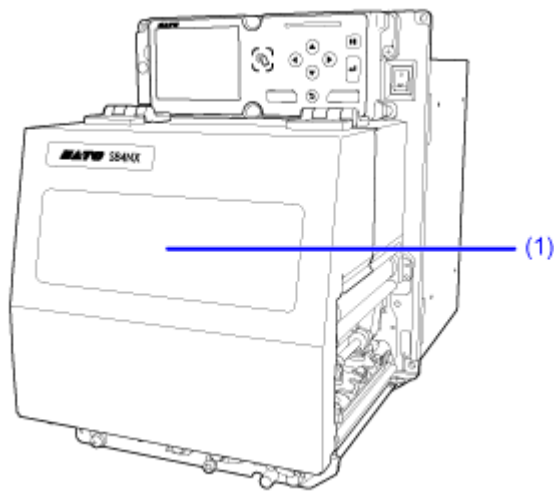

- **Checking through the notifications of the product**

The product has near-end and end detection functions for the ribbon, and end detection for the media.

Near-end detection of the media is also done by the sensor on the applicator.

With icons and error messages on the display of the product, you can check if you need to replace the media or ribbon soon, or if the remaining amount of media and ribbon is scarce.

## Conditions That Trigger Paper End

The conditions that trigger paper end vary depending on the operation of the product, and the sensor type selected.

If I-mark (reflective type) or Gap (transmissive type) is specified as the paper end sensor, then the paper end is detected according to the following conditions.

You can select the sensor type for paper end in the [Printing] > [Advanced] > [Paper End] > [Sensor Type] menu.

If [None] is specified as the paper end sensor, then the paper end is not detected.

### Conditions That Trigger Paper End in the Feeding Operation

- **When using I-mark for the paper-end sensor**

A paper-end occurs if the no-paper condition persists even after the I-mark sensor still detects the no-paper condition after 15 mm (0.59") has been fed.

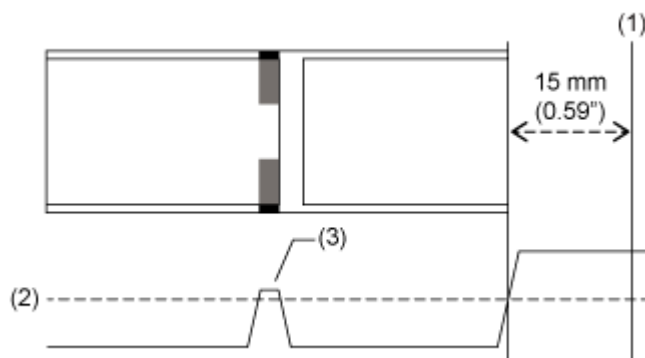

(1) Paper end detection

(2) Paper end detection level (fixed)

(3) I-mark sensor waveform

- **When using Gap for the paper-end sensor**

A paper-end occurs if the no-paper condition persists even after the gap sensor still detects the no-paper condition after the distance set as the detection distance has been fed.

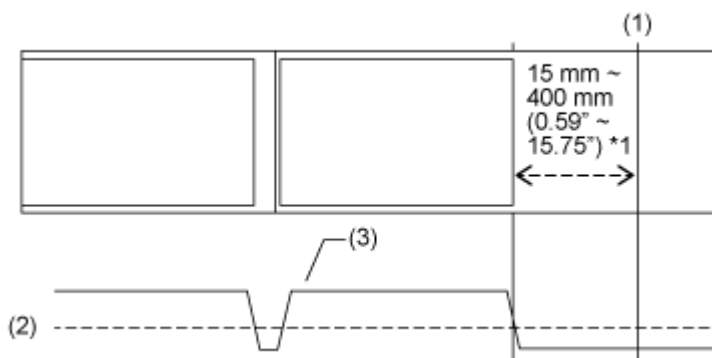

(1) Paper end detection

- (2) Paper end detection level (fixed)
- (3) Gap sensor waveform

\*1 The paper end distance can be set in the [Printing] > [Advanced] > [Paper End] > [Paper End Distance] menu.

**Conditions That Trigger Paper End in the Printing Operation**

1. The paper end sensor detects a no-paper condition at the position where feeding is done to the distance detected in the following table.

Paper End Sensor	Paper End Distance (mm (inch))	Setting Method
I-mark Sensor	15 (0.59")	Fixed
Gap Sensor	15 to 400 (0.59" to 15.75")	Set by the [Printing] > [Advanced] > [Paper End] > [Paper End Distance] menu or command

2. If the amount of printing remaining is less than the distance between the print head position and paper end sensor - the paper end distance shown in the table above, a paper end error occurs after completing the output of 1.

If the amount of printing remaining is more than the distance between the print head position and paper end sensor - the paper end distance shown in the table above, a paper end error occurs right after detecting the paper end, and the printer will reprint after clearing the paper end error.

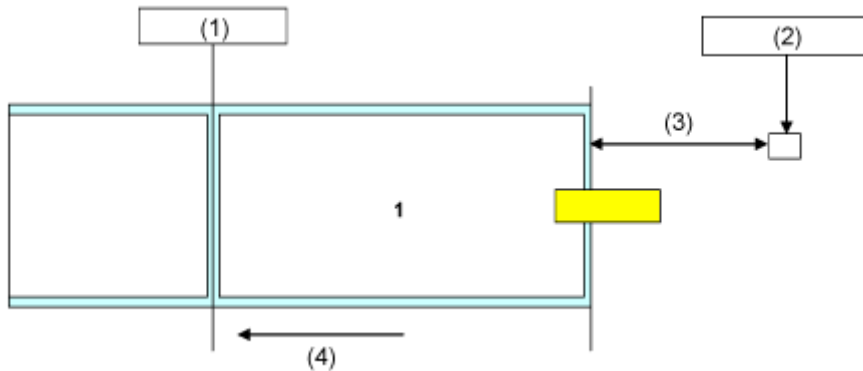

- (1) Print head position
- (2) Paper end sensor: I-mark sensor/Gap sensor  
Select in [Printing] > [Advanced] > [Paper End] menu, or specify by command.
- (3) Paper end distance
- (4) Media feed direction

If a paper end error is detected while printing, operation varies depending on the amounts of printing and media remaining when the error was detected.

The amount of media remaining can be calculated as follows:

Amount of media remaining = distance between print head position and paper end sensor - paper end distance

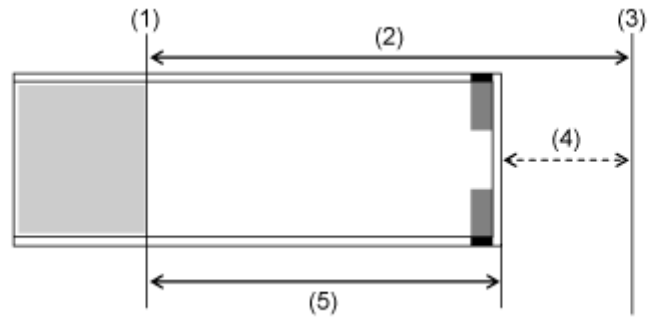

- (1) Print head position
- (2) Distance between the print head position and paper end sensor
- (3) Paper end sensor
- (4) Paper end distance
- (5) Amount of media remaining

- **When the Amount of Printing Remaining Is More Than the Amount of Media Remaining**

If the amount of printing remaining is more than the amount of media remaining when a paper end error is detected, the product cannot finish the print job. Printing stops immediately and a paper end error occurs.

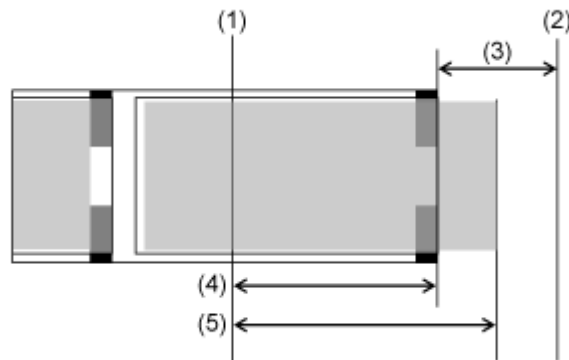

- (1) Print head position
- (2) Paper end sensor
- (3) Paper end distance
- (4) Amount of media remaining
- (5) Amount of printing remaining

- **When the Amount of Printing Remaining Is Less Than the Amount of Media Remaining**

If the amount of printing remaining is less than the amount of media remaining, the product will finish the print job and a paper end error will occur.

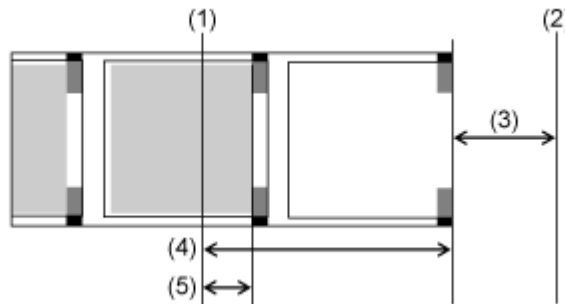

- (1) Print head position
- (2) Paper end sensor
- (3) Paper end distance
- (4) Amount of media remaining
- (5) Amount of printing remaining

If there are multiple sheets between the print head and paper end sensor when a paper end error is detected, a paper end error will occur only after finishing the label currently being printed.

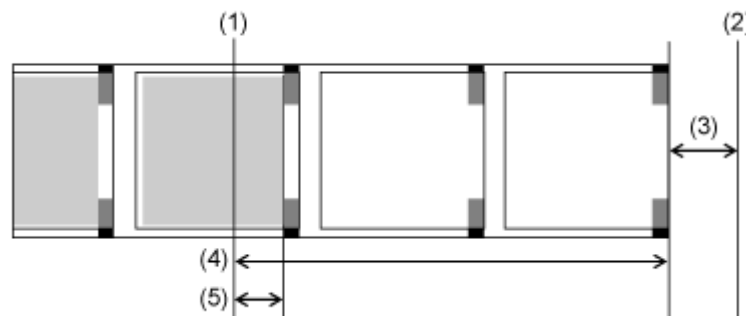

- (1) Print head position
- (2) Paper end sensor
- (3) Paper end distance
- (4) Amount of media remaining
- (5) Amount of printing remaining

In dispense & print mode, if a paper end error is detected while feeding labels printed, paper end may happen at the point that only the beginning of the label is printed. To continue the printing



operation after an error, eject the partially printed label to start printing. Reprinting starts by printing the interrupted print item on the next label.

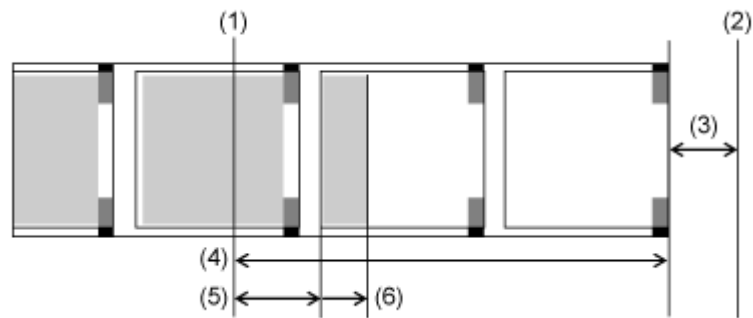

- (1) Print head position
- (2) Paper end sensor
- (3) Paper end distance
- (4) Amount of media remaining
- (5) Amount of printing remaining
- (6) Amount to feed until dispenser stop position

## Conditions That Trigger Label Near End

Label near end is detected by the label near end sensor on the applicator.

The label near end condition is received as an external signal from the applicator and a warning icon appears in the status bar on the upper part of the screen.



- Detection of the label near end is only for reference. The timing of label near end and paper end may overlap, or the paper end may occur before the label near end occurs depending on the label thickness and the top and bottom fluttering of the paper core.
-

## Conditions That Trigger Ribbon End (Thermal Transfer Only)

Ribbon end error is detected by the ribbon sensor in the ribbon supply spindle. Ribbon end error occurs when the product detects that the ribbon in the ribbon supply spindle has not moved (rolled) more than 32 mm (1.26") after feeding the media.

Following are the behaviors when detecting the ribbon end according to the remaining print job.

- When the amount of printing remaining is 12 mm (0.47") or more, the product generates a ribbon error immediately after detection.
- When the amount of printing remaining is less than 12 mm (0.47"), the product generates a ribbon error after printing is completed.
- When you have selected [Continuous] in the [Print Mode] menu as well as selecting [None] in the [Sensor Type] menu, or if you have selected [Linerless] in the [Print Mode] menu, then regardless of the amount of printing remaining, the product generates a ribbon error immediately after detection.
- When feeding, the product generates a ribbon error immediately after detection.

## Conditions That Trigger Ribbon Near End (Thermal Transfer Only)

Ribbon near end is detected by the ribbon sensor in the ribbon supply spindle. Ribbon near end occurs when the amount of ribbon remaining is approximately less than 15 meters (49.2 feet) (ribbon diameter: approximately 36 mm (1.42")).



- The amount of ribbon remaining (15 meters (49.2 feet)) is only for reference. The timing of ribbon near end varies depending on the ribbon thickness and the reading status of the ribbon sensor.
-

---

# Various Settings of the Product

---

## The Product's [Settings] Menu

---

The following categories of menus are available for the [Settings] menu of the product. Click the icon to jump to the description of each menu item.

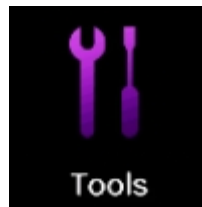
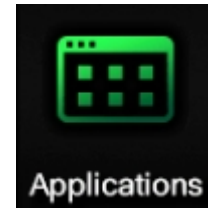

- The [Language] menu appears if you enable it by going to the [System] > [Regional] > [Display Language Icon] menu.
-



## [Shortcut] Menu



By registering setting items to the [Shortcut] menu, you can directly access registered setting items and change the settings during printing.



## [Printing] Menu

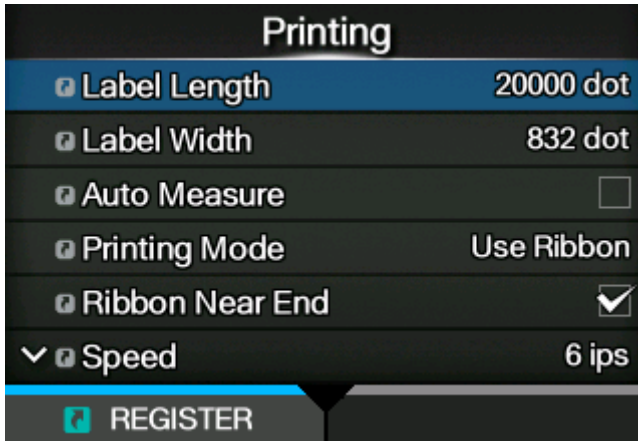

The following settings are available in the [Printing] menu:

### [Label Length]

Set the length of the media.

The setting range varies depending on the print resolution of the product.

The setting range of the label length is as follows:

Resolution	S84NX	S86NX
203 dpi (1 dot = 0.125 mm (0.0049"))	1 to 20000 dots	1 to 20000 dots
305 dpi (1 dot = 0.083 mm (0.0033"))	1 to 18000 dots	1 to 18000 dots
609 dpi (1 dot = 0.042 mm (0.0017"))	1 to 9600 dots	-



- Set the label size to a value that includes the liner.

### [Label Width]

Set the width of the media.

The setting range varies depending on the print resolution of the product.

The setting range of the label width is as follows:

Resolution	S84NX	S86NX
203 dpi (1 dot = 0.125 mm (0.0049"))	1 to 832 dots	1 to 1340 dots
305 dpi (1 dot = 0.083 mm (0.0033"))	1 to 1248 dots	1 to 2010 dots
609 dpi (1 dot = 0.042 mm (0.0017"))	1 to 2496 dots	-



- Set the label size to a value that includes the liner.



## [Auto Measure]

The product automatically measures the length of the media.

The measured length of the media will be automatically saved in [Label Length].

The Auto Measure function can be performed when [Sensor Type] is set to [Gap] or [I-Mark].

The setting procedure of the label length using the Auto Measure function is as follows:

1. Load the media.
2. Set [Auto Measure] to [Enabled].
3. Press the  button or  button to show the Online or Offline screen.
4. Open the print head. (Head Open error occurs.)
5. Close the print head. (The display returns to Offline screen.)
6. When you press the  button, the product feeds two pieces of label and measures the label length.
7. The measured label length is saved in [Label Length].



- When you enable [Auto Measure], this function executes in the following conditions:
  - The first time the product changes to Online mode after being powered on
  - When the product changes to Online mode after the top cover is opened/closed
  - When the product changes to Online mode after the settings in the [Sensor Type] menu are changed



- If [Protocol] in the [Applications] menu is changed to [SZPL], then [Auto Measure] is enabled and executes automatically.
- 

## [Printing Mode]

Set whether to print using a ribbon or direct thermal media.

Available only for the combined direct thermal/thermal transfer model.

The options are as follows:

### Use Ribbon

Print using a ribbon.

### Direct Thermal

Print using direct thermal media.

## [Ribbon Near End]

Set whether to detect ribbon near end when the ribbon is nearing the end.

When this setting is enabled and a ribbon near end is detected, this product operates as follows;

- Printing does not stop.
- The warning icon appears on the screen.
- The ribbon near end state is output to returning the product status and external signal.

Appears only if you have selected [Use Ribbon] in the [Printing Mode] menu on the combined direct thermal/thermal transfer model.

The options are as follows:

### Enabled

Enable detection of the ribbon near end.

### Disabled

Disable detection of the ribbon near end.



- The warning icon is shown in the status bar on the upper part of the screen.
- 

## [Speed]

Set the print speed.

The setting range varies depending on the print resolution of the product.

The setting range of the print speed is as follows:

Resolution	S84NX	S86NX
203 dpi (8 dots/mm)	4 to 16 ips (inches/sec) (101.6 to 406.4 mm/sec)	4 to 14 ips (inches/sec) (101.6 to 355.6 mm/sec)

Resolution	S84NX	S86NX
305 dpi (12 dots/mm)	4 to 14 ips (inches/sec) (101.6 to 355.6 mm/sec)	4 to 12 ips (inches/sec) (101.6 to 304.8 mm/sec)
609 dpi (24 dots/mm)	2 to 6 ips (inches/sec) (50.8 to 152.4 mm/sec)	-



- If [Enabled] is selected in the [Micro Label Print Mode] menu, the print speed has a maximum of 4 ips (inches/second).
- Setting the print speed to a level that is too fast may affect the print quality.

## [Sensor Type]

Set the sensor type for detecting the media.

The options are as follows:

### None

Disable the media sensor.

### Gap

Select when using gap type media. Use the transmissive type sensor.

### I-Mark

Select when using I-mark type media. Use the reflective type sensor.



- If you have selected [Dispenser] or [Dispense & Print] in the [Print Mode] menu, only [Gap] and [I-Mark] will be available.
- If you have selected [Linerless] in the [Print Mode] menu, only [None] will be available.

## [Micro Label Print Mode]

Set the micro label print mode operation.

Micro Label Print Mode is a mode to provide high accuracy printing for small sized labels.



- The accuracy of Micro Label Print Mode is dependent on the usage conditions, including quality of label production, print layout, and ribbon sizes.  
The following conditions are recommended,
  - Ribbon length: Less than 450 m
  - Used media sensor: Gap sensor
- The improved accuracy provided by micro label print mode is for labels sizes of less than the distance between the print head position and paper end sensor (incl. GAP).
- When the Micro Label Print Mode is enabled when print speed is 5 ips or above, the print speed will be automatically reduced to 4 ips.

- (S84NX only) When using RFID models, Micro Label Print Mode cannot be used.

The setting items are as follows:

### [Micro Label Print Mode]

Enable or disable the use of Micro Label Print Mode.

The options are as follows:

#### Enabled

Enable Micro Label Print Mode.

#### Disabled

Disable Micro Label Print Mode.

### [Auto Label Length Detection]

Enable or disable automatic measurement of label length when the [Micro Label Print Mode] is set to [Enabled].

The options are as follows:

#### Enabled

Enable the auto label length detection.

#### Disabled

Disable the auto label length detection.



- If the print start position is out of alignment when using automatic measurement of label length, use [Label Length] to set the label length manually.

### [Label Length Averaging Count]

Set the number of labels measured to be used for averaging the automatically set label length when the [Micro Label Print Mode] is set to [Enabled] and the [Auto Label Length Detection] is set to [Enabled].

The setting range is from 1 to 10.

### [Label Length]

Set the label length manually when the [Micro Label Print Mode] is set to [Enabled] and the [Auto Label Length Detection] is set to [Disabled].

The setting range varies depending on the print resolution of the product.

The setting range of the label length is as follows:

Resolution	S84NX	S86NX
203 dpi (1 dot = 0.125 mm (0.0049"))	72 to 960 dots	72 to 960 dots

Resolution	S84NX	S86NX
305 dpi (1 dot = 0.083 mm (0.0033"))	108 to 1440 dots	108 to 1440 dots
609 dpi (1 dot = 0.042 mm (0.0017"))	216 to 2880 dots	-



- Set the label size to a value that includes the liner.

## [Print Mode]

Set the print mode.

The options are as follows:

### Continuous

Continuously print the specified number of the media. The media remains in position for printing at all times.

### Dispenser

Peels the liner from the printed label as the label is fed to the media discharge outlet. Once the printed label has been removed from the product for application, the next label will retract and position itself for printing.

### Linerless

When specialized hardware is installed on the external equipment, then linerless labels are fed and printed.

### Dispense & Print

The printed label advances to the dispensing position while the next data is printed.

If the next data is not available, it is fed to the dispensing position without printing, then backfeed and regular dispensing are done.



- (S84NX only) Do not select Linerless Mode to use RFID tags on an RFID model. If you set Linerless Mode, you cannot use RFID tags.



- In the dispense & print mode, when printing is stopped, such as due to a cancel operation during printing of labels, feed and eject the labels that have been finished printing part way before restarting printing. Restarting without doing this would cause an error.
- When you are using the dispense & print mode, printing stops for a dispense operation, so a white void appears in the head position where printing stopped.

## [Backfeed]

[Backfeed] is applicable when the print mode is set to dispenser mode, linerless mode or dispense & print mode.

The options are as follows:

### None

Do not backfeed.

### After

After dispensing the label, backfeed the front part of the next label to the print head position.

### Before

Before printing, backfeed the front part of the next media to the print head position.

### Controlled

When a signal is received from the applicator after dispensing a label, the leading edge of the next label is back fed to the print head position.



- The selectable operations differ according to the print mode.

[Print Mode]	[None]	[After]	[Before]	[Controlled]
[Continuous]	Possible	-	-	-
[Dispenser]	-	Possible	Possible	Possible
[Linerless]	-	-	Possible	-
[Dispense & Print]	-	Possible	Possible	-

---

## [Darkness]

Specify the print darkness from 10 steps.

The setting range is from 1 to 10. 1 is the lightest and 10 is the darkest.



- To further fine tune the print darkness, set [Printing] > [Advanced] > [Adjustments] > [Darkness Adjust].
- 

## [Imaging]

Set the print reference position in the vertical and horizontal directions.

The setting items are as follows:

Vertical

Set the print position in the vertical direction.

Set the correction value from the print reference position as "-" for the direction of the paper feed and "+" for the direction opposite to the paper feed.

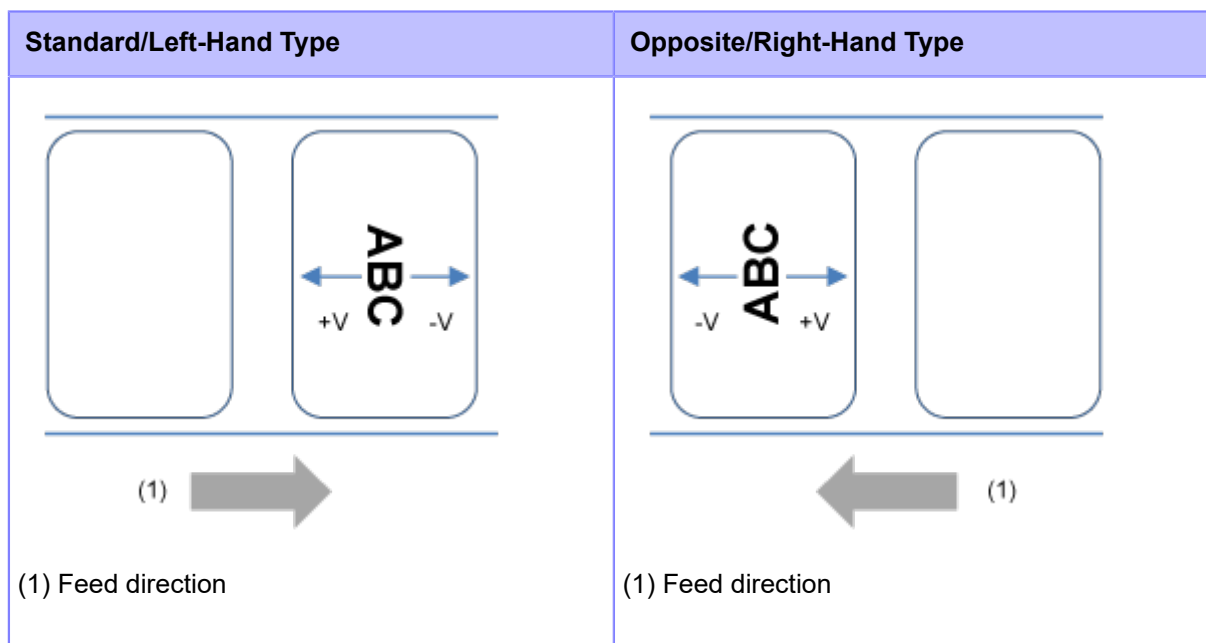

The setting range varies depending on the print resolution of the product.

The setting range is as follows:

Resolution	S84NX	S86NX
203 dpi (1 dot = 0.125 mm (0.0049"))	-19999 to 0 to 19999 dots	-19999 to 0 to 19999 dots
305 dpi (1 dot = 0.083 mm (0.0033"))	-17999 to 0 to 17999 dots	-17999 to 0 to 17999 dots
609 dpi (1 dot = 0.042 mm (0.0017"))	-9599 to 0 to 9599 dots	-

Horizontal

Set the print position in the horizontal direction.

Set the correction value from the print position when facing the product as "-" to adjust to the back side and "+" to adjust to the front side.

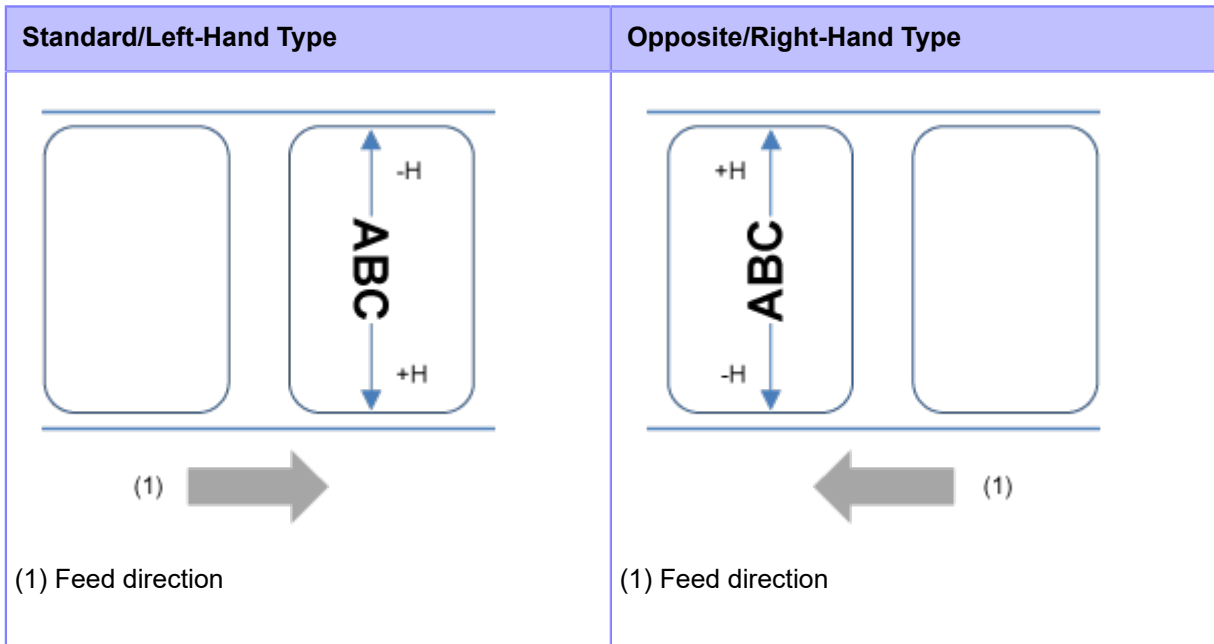

The setting range varies depending on the print resolution of the product.

The setting range is as follows:

Resolution	S84NX	S86NX
203 dpi (1 dot = 0.125 mm (0.0049"))	-831 to 0 to 831 dots	-1339 to 0 to 1339 dots
305 dpi (1 dot = 0.083 mm (0.0033"))	-1247 to 0 to 1247 dots	-2009 to 0 to 2009 dots
609 dpi (1 dot = 0.042 mm (0.0017"))	-2495 to 0 to 2495 dots	-



- You can change the units to dots, " (inches), or mm in the [System] > [Regional] > [Unit] menu.

### Adjusting Direction of the Print Reference Position and Base Reference Point

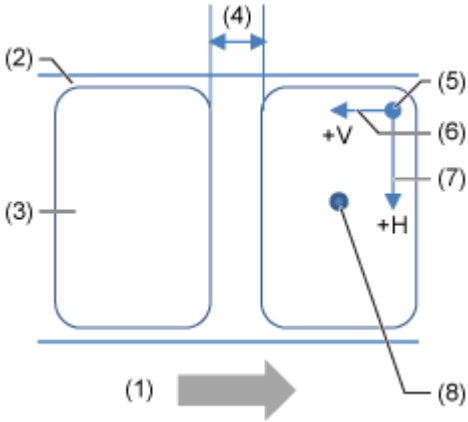
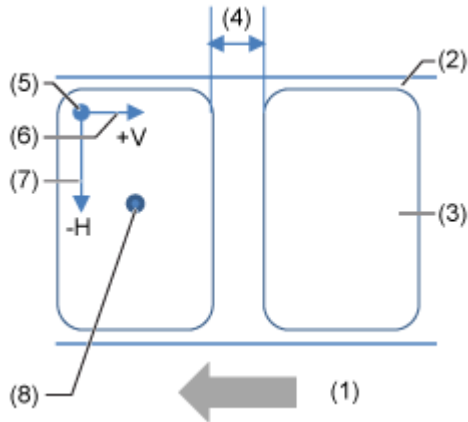
Standard/Left-Hand Type	Opposite/Right-Hand Type
 <p>(1) Feed direction                  (2) Liner                  (3) Label                  (4) Gap between labels                  (5) Print reference position (before correction)                  (6) Adjustment of vertical base reference point                  (7) Adjustment of horizontal base reference point                  (8) Base reference point after adjustment</p>	 <p>(1) Feed direction                  (2) Liner                  (3) Label                  (4) Gap between labels                  (5) Print reference position (before correction)                  (6) Adjustment of vertical base reference point                  (7) Adjustment of horizontal base reference point                  (8) Base reference point after adjustment</p>

**[Advanced]**

Set detailed sensor operation and print motion.

The setting items are as follows:

**[Calibrate]**

Adjust the media sensor level.

In instances of media detection malfunction, adjust the media sensor level (Gap and I-mark sensors).

The setting items are as follows:

**[Auto-calibration]**

Perform the auto-calibration for the selected media sensor.

[Auto-calibration] is not available if you have selected [Linerless] in the [Print Mode].

Gap + I-Mark

Adjusts both the Gap sensor and I-mark sensor.

Gap

Adjusts the Gap sensor.



## I-Mark

Adjusts the I-mark sensor.

The procedure to auto-calibrate the media sensor is as follows:

1. Open the top cover.
2. Turn the head lock lever clockwise to unlock the print head, and then pull the feed lock latch to unlock the feed roller and media sensor assembly.
3. Load the media.  
Remove the label from the liner and set the liner so the I-mark is not above the I-mark sensor.

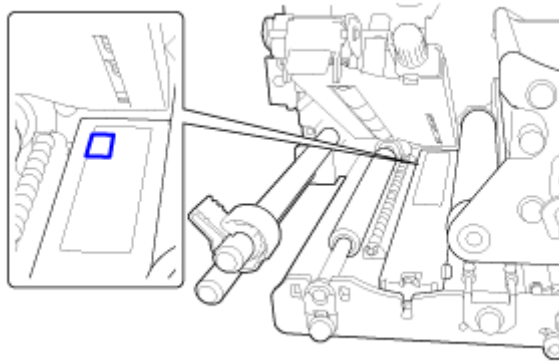

4. Turn the head lock lever counterclockwise to lock the print head, and then press the feed roller and media sensor assembly down until the feed lock latch is locked.



- Before the adjustment, confirm that the feed roller and media sensor assembly (sensor cover) is locked. If the assembly is not locked when auto-calibration is executed, the calibration will fail.

5. Close the top cover.
6. Press the ▲ / ▼ buttons to select the type of sensor to be adjusted.
7. Press the [REDACTED] button or [REDACTED] button.
8. When the confirmation screen appears, press the [REDACTED] button to start the sensor adjustment.
9. The result of the sensor adjustment is shown. To exit the adjustment, press the [REDACTED] button.
10. Set to Offline mode. Press the [REDACTED] button to confirm that the media is fed correctly.





- If the media is not fed correctly after doing [Auto-calibration], contact your SATO reseller or technical support.

## [GAP Levels]

Manually set the Gap sensor level.

The setting procedure is as follows:

First, adjust the "Low" level (voltage) of the Gap sensor.

1. Remove the label from the liner.
2. Pass the liner below the feed roller and media sensor assembly. Align it so that the media sensor does not detect the I-mark (black mark).
3. Close the print head and the feed roller and media sensor assembly. To get the correct adjustment result, adjust after you have closed them.
4. Select the [GAP Levels] in the [Calibrate] menu and press the  button.
5. Press the  buttons to change the [Emit] value until the [Sensor] value is below 0.5 (V). Set the [Emit] value as low as possible.
6. If the [Sensor] value does not decrease below 0.5 after you changed the [Emit] value, press the  buttons to change the [Receive] value.
7. Take a note of the [Sensor] value from the above procedure. This is the "Low" level value for the Gap sensor.

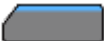

Next, check the "High" level (voltage) of the Gap sensor as follows:

1. Pass the media (attached with liner) below the feed roller and media sensor assembly. Align it so that the media sensor does not detect the I-mark (black mark).
2. Close the print head and the feed roller and media sensor assembly.
3. Check the [Sensor] value.  
If the value is 1.0 (V) higher than the "Low" level value you have recorded, this is the "High" level value for the Gap sensor.  
If the difference between the "High" and the "Low" levels is less than 1.0, adjust the [Emit] and [Receive] values so that the difference is more than 1.0, or adjust the "Low" level (voltage) of the Gap sensor again.
4. If both "High" and "Low" levels comply with the standard value, press the  button to confirm the value.  
The standard values for the "High" and "Low" levels for the Gap sensor are as follows:
  - Low (with only liner)  $\leq 0.5$  (V)
  - High (media attached with liner) - Low  $\geq 1.0$  (V)

### [GAP Slice Level]

Set the Gap sensor slice level.

The setting procedure is as follows:

1. Use the following formula to calculate the slice level:  
(High level - Low level) x 0.3 + Low level = slice level
2. Select the [GAP Slice Level] in the [Calibrate] menu and press the  button.
3. Press the  buttons to change the [Slice level] value. Set the [Slice level] to the level calculated in step 1.
4. Press the  button to confirm the value.







- If you set the [Slice level] to 0.0 (V), the product sets the slice level automatically.

### [I-Mark Levels]

Manually set the I-mark sensor level.

The setting procedure is as follows:

First, adjust the "Low" level (voltage) of the I-mark sensor.

1. Pass the media below the feed roller and media sensor assembly. Align it so that the media sensor does not detect the I-mark (black mark).
2. Close the print head and the feed roller and media sensor assembly.
3. Select the [I-Mark Levels] in the [Calibrate] menu and press the  button.
4. Press the  /  buttons to change the [Emit] value until the [Sensor] value is below 0.5 (V). Set the [Emit] value as low as possible.
5. If the [Sensor] value does not decrease below 0.5 after you changed the [Emit] value, press the  /  buttons to change the [Receive] value.
6. Take a note of the [Sensor] value from the above procedure. This is the "Low" level value for the I-mark sensor.

Next, check the "High" level (voltage) of the I-mark sensor as follows:

1. Pass the media (attached with liner) below the feed roller and media sensor assembly. Align it so that the media sensor does not detect the I-mark (black mark).
2. Close the print head and the feed roller and media sensor assembly. To get the correct adjustment result, adjust after you have closed them.
3. Check the [Sensor] value.  
If the value is 1.0 (V) higher than the "Low" level value you have recorded, this is the "High" level value for the I-mark sensor.  
If the difference between the "High" and the "Low" levels is less than 1.0, adjust the [Emit] and [Receive] values so that the difference is more than 1.0, or adjust the "Low" level (voltage) of the I-mark sensor again.
4. If both "High" and "Low" levels comply with the standard value, press the  button to confirm the value.

The standard values for the "High" and "Low" levels for the I-mark sensor are as follows:





- Low (without I-mark)  $\leq 0.5$  (V)
- High (with I-mark) - Low  $\geq 1.0$  (V)

### [I-Mark Slice Level]

Set the I-mark sensor slice level.

The setting procedure is as follows:

1. Use the following formula to calculate the slice level:  
(High level - Low level) x 0.7 + Low level = slice level

2. Select the [I-Mark Slice Level] in the [Calibrate] menu and press the  button.
3. Press the  /  buttons to change the [Slice level] value. Set the [Slice level] to the slice level calculated in step 1.
4. Press the  button to confirm the value.



- If you set the [Slice level] to 0.0 (V), the product sets the slice level automatically.
- 

### [Head Check]

Automatically check if there is a broken element of the print head.

The options are as follows:

#### Off

Disable the Head Check.

#### All

Check the entire print area.

#### Barcode

Check only the area for printing a barcode. Head check is not applicable for barcodes printed as graphic data.



- Head check is a reference for checking for a broken element of the print head. This function does not guarantee barcode readability. A regular barcode reader test is required. When a void of printing got up, the head check function may not work immediately. Some gaps may occur.

For the outputted label after the head error, perform the scanner reader of the printed barcode to check the label.

---

### [Head Check Mode]

Set the method for head check.

Appears if you have selected [All] or [Barcode] in the [Head Check] menu.

The options are as follows:

#### Always

Perform the head check for every item.

#### After Batch

The head check occurs before starting to print and when printing is stopped. If backfeed is applicable, the head check occurs before starting to print, when stopping to print and during the backfeed.

#### Every Page

Perform the head check for each specified number of media.

### [Every Page]

Perform the head check for each specified number of media.

Appears if you have selected [Every Page] in the [Head Check Mode] menu.

The setting range is from 1 to 999999.

### [Check Media Size]

Enable or disable media size check.

Appears if you have selected [Gap] or [I-Mark] in the [Sensor Type] menu.

If this function is enabled, "Media Error" is shown when either of the following conditions applies:

- If the media is more than 3 mm (0.12") longer than the media length specified with the media size command ESC+A1.
- If the current media feed length is more than 3 mm (0.12") longer than the media length fed for the first time after this function is enabled.

The options are as follows:

#### Enabled

Enable media size check.

#### Disabled

Disable media size check.

### [Adjustments]

Correct the offset position, print position and print darkness.

The setting items are as follows:

#### [Offset]

Correct the offset position.

Offset adjusts the backfeed/stop position for Dispense operation.

Set the value '+' to move the offset position in the direction opposite to the feed direction and '-' to move in the feed direction.

The setting range varies depending on the print resolution of the product.

The setting range is as follows:

Resolution	S84NX	S86NX
203 dpi (1 dot = 0.125 mm (0.0049"))	-30 to 0 to 30 dots	-30 to 0 to 30 dots
305 dpi (1 dot = 0.083 mm (0.0033"))	-45 to 0 to 45 dots	-45 to 0 to 45 dots
609 dpi	-90 to 0 to 90 dots	-

Resolution	S84NX	S86NX
(1 dot = 0.042 mm (0.0017"))		



- You can change the units to dots, " (inches), or mm in the [System] > [Regional] > [Unit] menu.
- The changes to this setting are linked and are changed with each of the test print settings in the [Tools] > [Test Print] menu.

**[Pitch]**

Pitch adjusts the print start position thus effects the vertical print position placement.

Set the value '+' to move print position in the direction opposite to the feed direction and '-' to move in the feed direction.

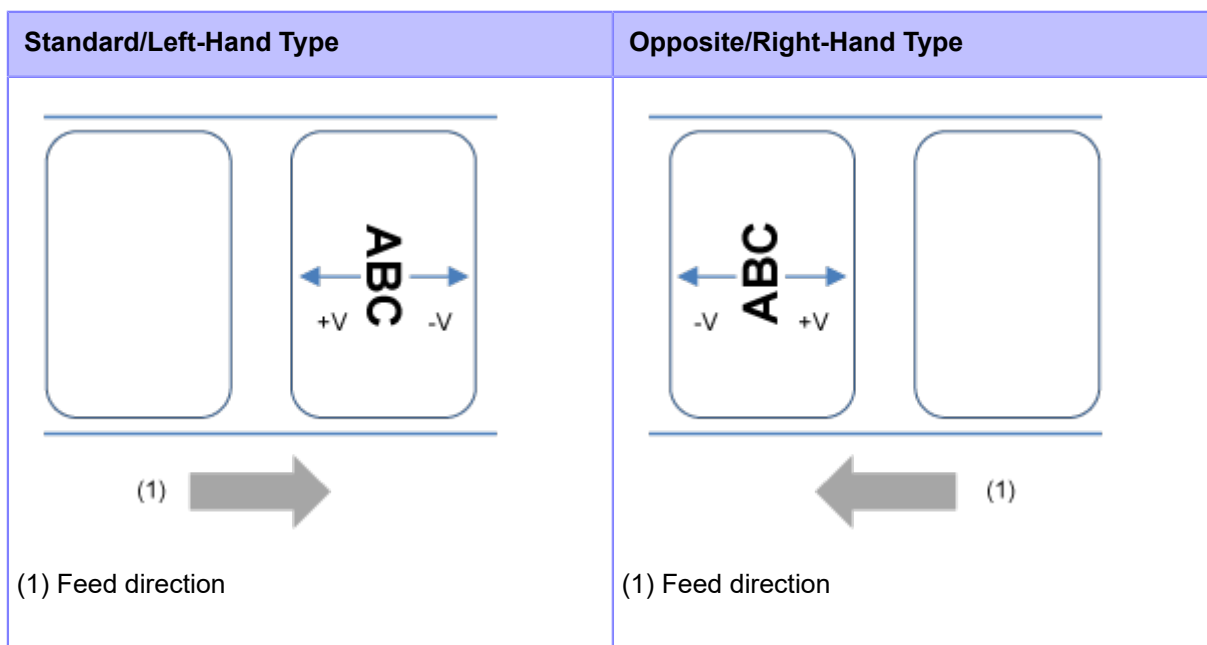

The setting range varies depending on the print resolution of the product.

The setting range is as follows:

Resolution	S84NX	S86NX
203 dpi (1 dot = 0.125 mm (0.0049"))	-30 to 0 to 30 dots	-30 to 0 to 30 dots
305 dpi (1 dot = 0.083 mm (0.0033"))	-45 to 0 to 45 dots	-45 to 0 to 45 dots
609 dpi (1 dot = 0.042 mm (0.0017"))	-90 to 0 to 90 dots	-



- You can change the units to dots, " (inches), or mm in the [System] > [Regional] > [Unit] menu.
- The changes to this setting are linked and are changed with each of the test print settings in the [Tools] > [Test Print] menu.

### [Pitch Offset]

Pitch Offset adjusts the offset position and the pitch position at the same time.

Set the value '+' to move the offset and pitch positions in the direction opposite to the feed direction and '-' to move in the feed direction.

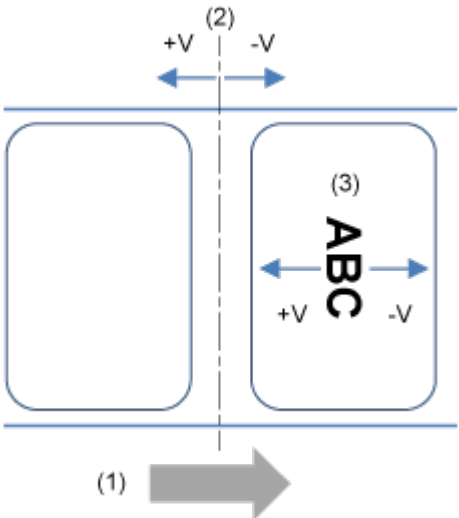
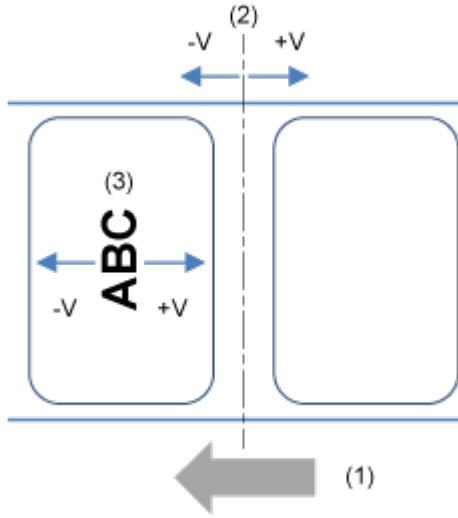
Standard/Left-Hand Type	Opposite/Right-Hand Type
 <p>(1) Feed direction</p> <p>(2) Offset position (backfeed/stop position for Dispense operation)</p> <p>(3) Pitch position (leading edge of media position that decides the vertical print position)</p>	 <p>(1) Feed direction</p> <p>(2) Offset position (backfeed/stop position for Dispense operation)</p> <p>(3) Pitch position (leading edge of media position that decides the vertical print position)</p>

The setting range varies depending on the print resolution of the product.

The setting range is as follows:

Resolution	S84NX	S86NX
203 dpi (1 dot = 0.125 mm (0.0049"))	-392 to 0 to 392 dots	-392 to 0 to 392 dots
305 dpi (1 dot = 0.083 mm (0.0033"))	-588 to 0 to 588 dots	-588 to 0 to 588 dots
609 dpi	-1176 to 0 to 1176 dots	-

Resolution	S84NX	S86NX
(1 dot = 0.042 mm (0.0017"))		



- You can change the units to dots, " (inches), or mm in the [System] > [Regional] > [Unit] menu.

### [Darkness Adjust]

Fine tune the print darkness.

The setting range is from 0 to 99.

0 is the lightest and 99 is the darkest.



- The changes to this setting are linked and are changed with each of the test print settings in the [Tools] > [Test Print] menu.

### [Start Online]

Select default mode when the product is powered on.

The options are as follows:

#### Enabled

The product powers on in Online mode.

#### Disabled

The product powers on in Offline mode.

### [Feed After Error]

Set whether to automatically feed the media when recovering from an error and changing to Online mode.

The options are as follows:

#### Enabled

Feed the media when changing to Online mode after recovering from an error.

#### Disabled

Do not feed the media when changing to Online mode after recovering from an error.

However, if [Feed At Power On] is set to [Enabled], the product feeds the media when it is powered on and changes to Online mode.

Also, if [Auto Measure] is enabled, the product feeds the media when it changes to Online mode for the first time after being powered on.

### [Feed At Power On]

Set whether to automatically feed the media when the product is powered on.

The options are as follows:



### Enabled

Feed the media when the product is powered on.

### Disabled

Do not feed the media when the product is powered on.

However, if [Auto Measure] is enabled, the product feeds the media when it changes to Online mode for the first time after being powered on.

## [Finisher Feed]

Set the media feed amount for dispense stop. Set the media feed amount based on the print head position of 0.

The actual media feed amount is the value of [Offset] + [Finisher Feed].

The setting range varies depending on the print resolution of the product.

The setting range is as follows:

Resolution	S84NX	S86NX
203 dpi (1 dot = 0.125 mm (0.0049"))	0 to 2040 dots	0 to 2040 dots
305 dpi (1 dot = 0.083 mm (0.0033"))	0 to 3060 dots	0 to 3060 dots
609 dpi (1 dot = 0.042 mm (0.0017"))	0 to 6120 dots	-



- When [Printing Mode] is set to [Use Ribbon], the length of label backfeed needs to be under 30 mm (1.18"). If it is over 30 mm (1.18"), the end of the ribbon may be falsely detected.
  - You can change the units to dots, " (inches), or mm in the [System] > [Regional] > [Unit] menu.
  - A message prompting you to restart the product will appear on the Online/Offline screen if you have made any changes. In such a case, reboot the product to apply the settings.
- 

## [Feed Speed]

Set the speed that media feeds.

The setting items are as follows:

### [Sync with Print Speed]

The feed speed setting is set to the same value as the print speed setting.

The options are as follows:

Enabled

The feed speed setting is linked with the setting in the [Printing] > [Speed] menu.

Disabled

Manually set the feed speed in [Feed Speed].

**[Feed Speed]**

Manually set the feed speed.

Can be set if [Sync with Print Speed] is disabled.

The setting range is as follows:

Resolution	S84NX	S86NX
203 dpi (8 dots/mm)	4 to 16 ips (inches/sec) (101.6 to 406.4 mm/sec)	4 to 14 ips (inches/sec) (101.6 to 355.6 mm/sec)
305 dpi (12 dots/mm)	4 to 14 ips (inches/sec) (101.6 to 355.6 mm/sec)	4 to 12 ips (inches/sec) (101.6 to 304.8 mm/sec)
609 dpi (24 dots/mm)	2 to 6 ips (inches/sec) (50.8 to 152.4 mm/sec)	-



- Can be specified only for speeds lower than the value set in the [Speed] menu.
- If [Enabled] is selected in the [Micro Label Print Mode] menu, the feed speed has a maximum of 4 ips (inches/second).

**[Backfeed Speed]**

Set the backfeed speed.

The setting range of the backfeed speed is from 2 to 8 ips (inches/sec) (50.8 to 203.2 mm/sec) regardless of the printing resolution.

**[Paper End]**

Select the sensor for sensing the paper end and adjust the detection distance of the paper end.

The setting items are as follows:

**[Sensor Type]**

Set the sensor for detecting the paper end.

The options are as follows:

Using I-mark

Use the I-mark sensor (reflective type) to detect the paper end.

The detection distance is 15 mm (0.59") (fixed position).

### Using Gap

Use the Gap sensor (transmissive type) to detect the paper end.

The detection distance can be set in the range of 15 mm to 400 mm (0.59" to 15.75") in [Paper End Distance].

### None

Disable the paper end detection.

## [Paper End Distance]

Adjust the detection distance of the paper end when [Sensor Type] is set to [Using Gap].

Available only if you have selected [Using Gap] in the [Sensor Type] menu.

The setting range is as follows:

Resolution	S84NX	S86NX
203 dpi (1 dot = 0.125 mm (0.0049"))	120 to 3200 dots	120 to 3200 dots
305 dpi (1 dot = 0.083 mm (0.0033"))	180 to 4800 dots	180 to 4800 dots
609 dpi (1 dot = 0.042 mm (0.0017"))	360 to 9600 dots	-



- You can change the units to dots, " (inches), or mm in the [System] > [Regional] > [Unit] menu.
- 

## [Head Base Position] (S84NX Only)

Set the position used for the base reference point for printing.

The options are as follows:

### Standard

Print with a standard base reference point.

### Left-justify

Move the print base reference point 2 mm (0.08") toward the rear (when facing the product).



- A message prompting you to restart the product will appear on the Online/Offline screen if you have made any changes. In such a case, reboot the product to apply the settings.
-

**[Prioritize]**

For product settings, set whether to prioritize the settings that are done through the product or through commands.

The options are as follows:

Commands

Prioritize the settings through commands.

Settings

Prioritize the settings that are done through the product.

**[Reprint]**

Enable or disable the reprint function.

The options are as follows:

Enabled

Enable the reprint function.

Disabled

Disable the reprint function.

If you have selected [Enabled] in [Reprint], you can press the  button ([REPRINT]) on the Online screen to print the previous data again.



- The previous data will be lost if you power off the product.

**[Print End Position]**

Adjust the media stop position when the [Sensor Type] is set to [None]. This adjustment also sets the blank amount from the media stop position.

The setting range varies depending on the print resolution of the product.

The setting range is as follows:

Resolution	S84NX	S86NX
203 dpi (1 dot = 0.125 mm (0.0049"))	0 to 20000 dots	0 to 20000 dots
305 dpi (1 dot = 0.083 mm (0.0033"))	0 to 18000 dots	0 to 18000 dots
609 dpi (1 dot = 0.042 mm (0.0017"))	0 to 9600 dots	-



- You can change the units to dots, " (inches), or mm in the [System] > [Regional] > [Unit] menu.
- 

### [Calendar Setting Mode]

Set the settings for the calendar function.

The setting items are as follows:

### [Calendar Reprint]

Set whether to update the date and time when doing reprinting with the reprint operation.



- With the reprint operation done if printing is stopped because an error occurs, the date and time are updated even if this setting is [Disabled].
- 

The options are as follows:

#### Enabled

The updated calendar data is included in the reprint data.

#### Disabled

Print exactly the same data as the last print job.

### [Day of Week Code]

Set the day of the week code for the calendar command.

The setting items are as follows:

#### [Sunday] to [Saturday]

Assign characters to each day of the week.

The setting range is from 0 to 9, A to Z, and a to z.

### [Month Code]

Set the month code for the calendar command.

The setting items are as follows:

#### [January] to [December]

Assign characters to each month.

The setting range is from A to Z, and a to z.

### [Case Format]

Select the character format for the calendar.

The options are as follows:

#### Mixed

Use upper case for the first character only.

Example: Sunday/Sun

### Upper

Use upper case for all characters.

Example: SUNDAY/SUN

### [Calendar Check]

Set whether to judge if the time acquired from the battery for the calendar is correct.

By selecting [Enabled], a calendar error occurs when time is judged to be incorrect, such as due to a dead battery, etc.

The options are as follows:

#### Enabled

Enable the calendar check function.

#### Disabled

Disable the calendar check function.

### [Work Shift Setting Mode]

This mode allows for specific production shift information to be printed on a label when used with the SBPL command.

The setting items are as follows:

#### [1] to [3]

Set the work shift start time and name of the specified work shift code.

You can set up to three shifts depending on the number of work shifts required in the field. For example, if two shifts are required, set work shift number 1 and 2.

The setting items are as follows:

#### [Shift Code]

Enable or disable the work shift setting mode.

#### [Shift Time]

Set the work shift start time.

Available only if you have selected [Enabled] in the [Shift Code] menu.

The setting range is from "00:00" to "23:59".

#### [Shift Name]

Set a name for the work shift.

Available only if you have selected [Enabled] in the [Shift Code] menu.

The number of characters you can set is as follows:

ASCII: 16 characters

### [Ribbon Tension Adjustment]

Adjust the delay in the timing of the platen roller drive against the ribbon rewind shaft drive. If ribbon smudging (marks from the friction of the carbon ribbon and the label surface) is observed, the setting can be adjusted to reduce that.

When you decrease the setting value, the delay for the platen roller drive is reduced.

When you increase the setting value, the delay for the platen roller drive is increased.

Appears only if you have selected [Use Ribbon] in the [Printing Mode] menu on the combined direct thermal/thermal transfer model.

The setting range is from 0 to 15 regardless of the printing resolution.

### [Printing Operations]

Set detailed printing operations.

The setting items are as follows:

#### [Throughput Mode]

Enable or disable the throughput mode.

When this setting is enabled, the interval from backfeed to forward feed or from forward feed to backfeed is shortened, and the throughput is improved.

#### [Extended Backfeed Operation]

Enable or disable the extended backfeed operation.

Appears if you have selected [Dispenser] in the [Print Mode] menu as well as selecting [Before] in the [Backfeed] menu.

By enabling this function, when using the external signal (EXT) interface, print data is received and at the stage that printing becomes possible, then backfeed is done and it waits for input of the Print Start signal (PRIN).

### [Page Clipping Mode]

Enable or disable the page clipping mode.

By enabling the page clipping mode, printing cuts off outside print areas as a separation at the print positions.

The print position moves according to the values set in the [Pitch] or [Pitch Offset] in the [Printing] > [Advanced] > [Adjustments] menu.

The figure below shows the state with no print position adjustment ( $\pm 0$ ) when the Gap sensor is used.

Disabled

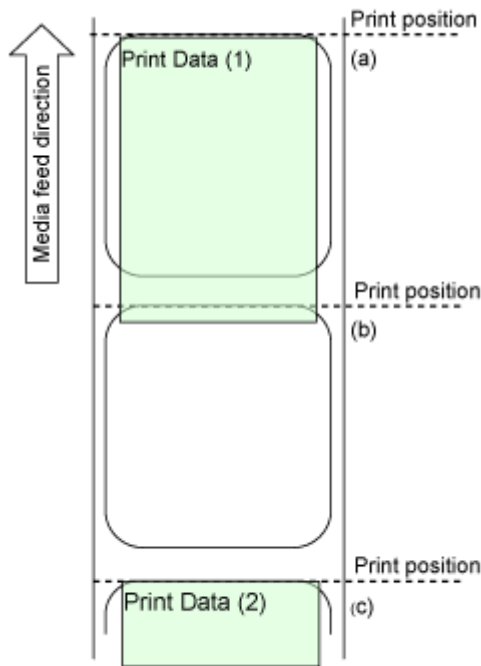

If print data (1) goes past the print position (b), then the next printing is done at print position (c).

Printing is done at print position (b), so it is excluded from being a reference position because it is a position where printing and dispensing-stop cannot be done.

Enabled

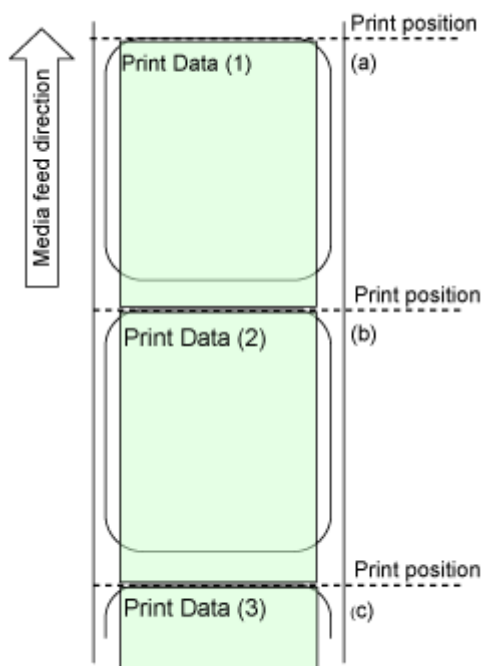

Print data (1) stops printing at print position (b). The next printing is done from print position (b).





- Do not design label layouts so that important information, such as barcodes, 2D codes, or prices, adjacent to where labels are separated.

We recommend using this function to check the results of printing as much as possible, such as barcode reading and image verification.

- Do not create designs that position items that are not printed on the label in print-positions that are not on the label.

They will be printed on the label by printers other than this printer or if the label is large. Also, in some cases, on subsequent models with different functions, commands may no longer be usable.

- This function basically operates by using a media sensor to detect where labels are separated. If labels are skewed (fed too little, fed too much, backfed too little) as they feed, then unwanted operations may occur, such as printing cutting off to leave blank spaces on the label, or printing being output on the top of the next label.

When using this function, keep appropriate tension for collection of liners and label supply.

### [Feed Offset]

Set the feed distance in linerless mode.

Appears only if you have selected [Linerless] in the [Print Mode] menu.

The setting range is as follows:

Resolution	S84NX	S86NX
203 dpi (1 dot = 0.125 mm (0.0049"))	0 to 2000 dots	0 to 2000 dots
305 dpi (1 dot = 0.083 mm (0.0033"))	0 to 3000 dots	0 to 3000 dots
609 dpi (1 dot = 0.042 mm (0.0017"))	0 to 6000 dots	-



- You can change the units to dots, " (inches), or mm in the [System] > [Regional] > [Unit] menu.

### [Backfeed Offset]

Set the backfeed distance in linerless mode.

Appears only if you have selected [Linerless] in the [Print Mode] menu.

The setting range is as follows:

Resolution	S84NX	S86NX
203 dpi	0 to 2000 dots	0 to 2000 dots

Resolution	S84NX	S86NX
(1 dot = 0.125 mm (0.0049"))		
305 dpi (1 dot = 0.083 mm (0.0033"))	0 to 3000 dots	0 to 3000 dots
609 dpi (1 dot = 0.042 mm (0.0017"))	0 to 6000 dots	-



- When [Printing Mode] is set to [Use Ribbon], the length of label backfeed needs to be under 30 mm (1.18"). If it is over 30 mm (1.18"), the end of the ribbon may be falsely detected.
  - You can change the units to dots, " (inches), or mm in the [System] > [Regional] > [Unit] menu.
-



## [Interface] Menu

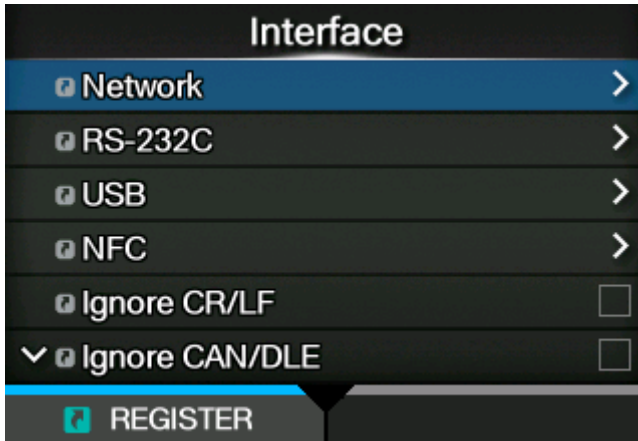

The following settings are available in the [Interface] menu:



- (S84NX only) The [RFID] menu appears only for the RFID models.

## [Network]

This menu is for using LAN and wireless LAN for the interface between the computer and the product.

The setting items are as follows:

## [Settings]

Set the LAN or wireless LAN, or select the interface.



- You cannot use LAN and wireless LAN at the same time. The wireless LAN function is available only if you have installed the wireless LAN.

The setting items are as follows:

## [LAN]

Set the IPv4, IPv6 or proxy for the LAN.

The setting items are as follows:

## [IPv4]

Set IPv4 for the LAN.



- After doing the settings, press the  button to enable the new settings. Press the  button to cancel the new settings and return to the previous settings.



- You cannot change [IP Address], [Netmask], [Gateway], or [DNS] when [Mode] is [DHCP].
- 

The setting items are as follows:

#### [Mode]

Select the IP address assignment method.

The options are as follows:

##### DHCP

Automatically retrieve the IP address, gateway and subnet mask from the DHCP server.

##### Static

Manually set the IP address, gateway and subnet mask.

#### [DHCP]

Update the lease time and get the IP address from the DHCP server again.

Appears only if you have selected [DHCP] in the [Mode] menu and LAN is the active interface.

Does not appear if the wireless LAN is the active interface.

#### [IP Address]

If you have selected [Static] in the [Mode] menu, set the IP address.

The setting range is as follows:

000.000.000.000 to 255.255.255.255

#### [Netmask]

If you have selected [Static] in the [Mode] menu, set the subnet mask address.

Each group of the address can be set cyclically among 0, 128, 192, 224, 240, 248, 252, 254 and 255.

The setting range is as follows:

128.000.000.000 to 255.255.255.254

#### [Gateway]

If you have selected [Static] in the [Mode] menu, set the default gateway address.

The setting range is as follows:

000.000.000.000 to 255.255.255.255

#### [DNS]

If you have selected [Static] in the [Mode] menu, set and check DNS server addresses.

The setting range is as follows:

000.000.000.000 to 255.255.255.255



- You can register up to three IP addresses for the DNS server. Use a comma to delimit different IP addresses.
-

## [IPv6]

Set the IPv6 for the LAN.



- After doing the settings, press the  button to enable the new settings. Press the  button to cancel the new settings and return to the previous settings.



- You cannot change [IP Address], [Prefix Length], [Gateway], or [DNS] if [Mode] is anything other than [Static].
- 

The setting items are as follows:

### [Mode]

Select the IP address assignment method or disable IPv6.

The options are as follows:

#### Disable

Disable IPv6.

#### Auto

Automatically generate the IP address and gateway (stateless mode).

#### DHCP

Automatically retrieve the IP address and gateway from the DHCP server (stateful mode).

#### Static

Manually set the IP address, gateway and prefix length.

### [DHCP]

Update the lease time and get the IP address from the DHCP server again.

Appears only if you have selected [DHCP] in the [Mode] menu.

Does not appear if the wireless LAN is the active interface.

### [IP Address]

If you have selected [Static] in the [Mode] menu, set the IP address.

The setting range is as follows:

0:0:0:0:0:0:1 to ffff:ffff:ffff:ffff:ffff:ffff:ffff

### [Prefix Length]

If you have selected [Static] in the [Mode] menu, set the prefix.

The setting range is from 1 to 128.

### [Gateway]

If you have selected [Static] in the [Mode] menu, set the default gateway address.

The setting range is as follows:

0:0:0:0:0:0:0 to ffff:ffff:ffff:ffff:ffff:ffff:ffff

**[DNS]**

If you have selected [Static] in the [Mode] menu, set the primary address of the DNS server.

The setting range is as follows:

0:0:0:0:0:0:0 to ffff:ffff:ffff:ffff:ffff:ffff:ffff



- You can register only one IP address for the DNS server for IPv6.
- 

**[Proxy]**

Set the proxy for the LAN.

The setting items are as follows:

**[Enabled]**

Enable or disable use of proxy.

The options are as follows:

Enabled

Enable proxy server usage.

Disabled

Disable proxy server usage.



- To enable the proxy, [Server] should be set and [Exclude] must contain at least 127.0.0.1 and localhost.
- 

**[Server]**

Set the name or IP address of the proxy server.

Example of input) http://172.128.1.100



- Be sure to specify a format for the IP address that starts with http. If you specify an address that starts with https, then the certification check is not done and connection to a legitimate SOS server may be impossible.
- 



- Server should be set with a valid name or IP address.
- 

**[Port No.]**

Set the port number that allows communication with the proxy server.

The setting range is from 1 to 65535.



- Set a port number not used by other services. If port numbers that overlap with those used by other services are used, communication cannot be performed properly.
- 



- To set the port number, [Server] should be set.
-

### [Username]

Set the username if you need a username to connect to the proxy server.

You can enter 1 to 8 characters. Alphabets (capital and small letters) and numbers can be used.



- To set the username, [Server] should be set.
- 

### [Password]

Set the password if you need a password to connect to the proxy server.

You can enter 1 to 16 characters. Alphabets (capital and small letters), numbers and symbols can be used.



- Some symbols cannot be used. If you enter a symbol that cannot be used, [Invalid value] appears on the screen.
- 



- To set the password, [Server] should be set.
- 

### [Exclude]

Set names, IP addresses or domains for the proxy to exclude.



- Exclude must contain at least 127.0.0.1 and localhost.
- 

### [DHCP Options]

Set the DHCP options for the LAN.

[DHCP Options] can be set only if you have selected [DHCP] in the [IPv4] > [Mode] menu or [IPv6] > [Mode] menu.

The setting items are as follows:

#### [Update DNS (Option 81)]

Enable or disable the use of DHCP server option 81.

The options are as follows:

##### Enabled

Enable the use of DHCP server option 81.

##### Disabled

Disable the use of DHCP server option 81.

### [Hostname]

Set the hostname.

You can enter 0 to 255 characters. Alphabets (capital and small letters), numbers and symbols can be used.



- Some symbols cannot be used. If you enter a symbol that cannot be used, [Invalid value] appears on the screen.



- Periods can be input only as delimiter text.
- If left blank, the setting is disabled.

## [Wi-Fi]

Set the wireless LAN.

Appears only if you have installed the optional wireless LAN.



- After doing the settings, press the  button to enable the new settings. Press the  button to cancel the new settings and return to the previous settings.





- When [Wi-Fi Direct] is active, [IPv6] and [Wi-Fi Protected Setup] do not appear on the screen.

The setting items are as follows:

## [IPv4]

Configure IPv4 for Wi-Fi.

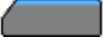

- After doing the settings, return to the [Wi-Fi] screen by pressing the  button, and then press the  button to enable the new settings. Press the  button to cancel the new settings and return to the previous settings.



- When [Wi-Fi Direct] is active, [Mode], [DHCP] and [DNS] do not appear. In addition, you cannot change [IP Address], [Netmask], or [Gateway] if [DHCP] or [Wi-Fi Direct] is active. [DNS] cannot be changed if [Mode] is [DHCP].

The setting items are as follows:

## [Mode]

Select the IP address assignment method.

The options are as follows:

### DHCP

Automatically retrieve the IP address, gateway and subnet mask from the DHCP server.

### Static

Manually set the IP address, gateway and subnet mask.

## [DHCP]

Update the lease time and get the IP address from the DHCP server again.

Appears only if you have selected [DHCP] in the [Mode] menu.



Does not appear if LAN is the active interface.

### [IP Address]

If you have selected [Static] in the [Mode] menu, set the IP address.

The setting range is as follows:

000.000.000.000 to 255.255.255.255

### [Netmask]

If you have selected [Static] in the [Mode] menu, set the subnet mask address.

Each group of the address can be set cyclically among 0, 128, 192, 224, 240, 248, 252, 254 and 255.

The setting range is as follows:

128.000.000.000 to 255.255.255.254

### [Gateway]

If you have selected [Static] in the [Mode] menu, set the default gateway address.

The setting range is as follows:

000.000.000.000 to 255.255.255.255

### [DNS]

If you have selected [Static] in the [Mode] menu, set and check DNS server addresses.

The setting range is as follows:

000.000.000.000 to 255.255.255.255





- You can register up to three IP addresses for the DNS server. Use a comma to delimit different IP addresses.
- 

### [IPv6]

Configure IPv6 for Wi-Fi.

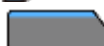

- After doing the settings, return to the [Wi-Fi] screen by pressing the  button, and then press the  button to enable the new settings. Press the  button to cancel the new settings and return to the previous settings.
- 



- When [Wi-Fi Direct] is active, this [IPv6] screen does not appear. In addition, you cannot change [IP Address], [Prefix Length], [Gateway], or [DNS] if [Mode] is anything other than [Static].
- 

The setting items are as follows:

### [Mode]

Select the IP address assignment method or disable IPv6.

The options are as follows:

#### Disable

Disable IPv6.

Auto

Automatically generate the IP address and gateway (stateless mode).

DHCP

Automatically retrieve the IP address and gateway from the DHCP server (stateful mode).

Static

Manually set the IP address, gateway and prefix length.

**[DHCP]**

Update the lease time and get the IP address from the DHCP server again.

Appears only if you have selected [DHCP] in the [Mode] menu.

Does not appear if LAN is the active interface.

**[IP Address]**

If you have selected [Static] in the [Mode] menu, set the IP address.

The setting range is as follows:

0:0:0:0:0:0:0:1 to ffff:ffff:ffff:ffff:ffff:ffff:ffff:ffff

**[Prefix Length]**

If you have selected [Static] in the [Mode] menu, set the prefix.

The setting range is from 1 to 128.

**[Gateway]**

If you have selected [Static] in the [Mode] menu, set the default gateway address.

The setting range is as follows:

0:0:0:0:0:0:0:0 to ffff:ffff:ffff:ffff:ffff:ffff:ffff:ffff

**[DNS]**

If you have selected [Static] in the [Mode] menu, set the primary address of the DNS server.

The setting range is as follows:

0:0:0:0:0:0:0:0 to ffff:ffff:ffff:ffff:ffff:ffff:ffff:ffff



- You can register only one IP address for the DNS server for IPv6.
- 

**[Proxy]**

Configure the proxy for Wi-Fi.

The setting items are as follows:

**[Enabled]**

Enable or disable use of proxy.

The options are as follows:

### Enabled

Enable proxy server usage.

### Disabled

Disable proxy server usage.



- To enable the proxy, [Server] should be set and [Exclude] must contain at least 127.0.0.1 and localhost.
- 

### [Server]

Set the name or IP address of the proxy server.

Example of input) http://172.128.1.100



- Be sure to specify a format for the IP address that starts with http. If you specify an address that starts with https, then the certification check is not done and connection to a legitimate SOS server may be impossible.
- 



- Server should be set with a valid name or IP address.
- 

### [Port No.]

Set the port number that allows communication with the proxy server.

The setting range is from 1 to 65535.



- Set a port number not used by other services. If port numbers that overlap with those used by other services are used, communication cannot be performed properly.
- 



- To set the port number, [Server] should be set.
- 

### [Username]

Set the username if you need a username to connect to the proxy server.

You can enter 1 to 8 characters. Alphabets (capital and small letters) and numbers can be used.



- To set the username, [Server] should be set.
- 

### [Password]

Set the password if you need a password to connect to the proxy server.

You can enter 1 to 16 characters. Alphabets (capital and small letters), numbers and symbols can be used.



- Some symbols cannot be used. If you enter a symbol that cannot be used, [Invalid value] appears on the screen.
-



- To set the password, [Server] should be set.
- 

### [Exclude]

Set names, IP addresses or domains for the proxy to exclude.

---



- Exclude must contain at least 127.0.0.1 and localhost.
- 

### [DHCP Options]

Configure the DHCP options for Wi-Fi.

[DHCP Options] can be set only if you have selected [DHCP] in the [IPv4] > [Mode] menu or [IPv6] > [Mode] menu.

The setting items are as follows:

#### [Update DNS (Option 81)]

Enable or disable the use of DHCP server option 81.

The options are as follows:

##### Enabled

Enable the use of DHCP server option 81.

##### Disabled

Disable the use of DHCP server option 81.

### [Hostname]

Set the hostname.

You can enter 0 to 255 characters. Alphabets (capital and small letters), numbers and symbols can be used.

---



- Some symbols cannot be used. If you enter a symbol that cannot be used, [Invalid value] appears on the screen.
- 



- Periods can be input only as delimiter text.
  - If left blank, the setting is disabled.
- 

### [Wi-Fi Protected Setup]

Set the wireless LAN connection using the push button or PIN code method.

---



- Refer to the manual of the access point device for its operation.
  - This screen does not appear if [LAN] or [Wi-Fi Direct] is active.
- 

The setting items are as follows:

### [Button (PBC)]

Set the wireless LAN connection using the push button method.

1. Select [Button (PBC)] in the [Wi-Fi Protected Setup] menu and press the  button.
2. When [Scanning...] appears on the screen, press the WPS button on the access point of the wireless LAN device.
3. When the connection to the access point is established, [Successfully configured.] appears on the screen.



- When the connection to the access point is failed, [Failed to find an Access Point.] appears on the screen.
- 

## [PIN]

Set the wireless LAN connection using the PIN code method.

1. Select [PIN] in the [Wi-Fi Protected Setup] menu and press the  button.
2. When [Scanning...] appears on the screen, set the PIN code shown on the screen to the access point of the wireless LAN or computer.
3. When the connection to the access point is established, [Successfully configured.] appears on the screen.



- When the connection to the access point is failed, [Failed to find an Access Point.] appears on the screen.
- 



## [Wi-Fi Direct]

Set the Wi-Fi Direct function.



The Wi-Fi Direct function is enabled if you have selected [Infrastructure] in the [Mode] menu. If you have changed the setting from [Ad-hoc] to [Infrastructure] in the [Mode] menu, reboot the product before setting the Wi-Fi Direct function.

The setting procedure is as follows:

1. Set the device name for the product using [Device Name]. You can enter 1 to 32 characters. Alphabets (capital and small letters), numbers and symbols can be used.

Press the  button to return to the [Wi-Fi] menu and press the  button to enable changes.

2. Select [Connect] to search and show the connectable device names or to accept connection requests when the product is the GO (Group Owner).

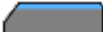
Select the device name you want to connect using the  /  buttons, and press the  button.

3. Select [Start Group] if you want to start a new persistent group or select a group from the list.
4. Select [Remove Group] to remove the persistent group in step 3.
5. Complete the connection according to the display on the product or device you want to connect.
6. Select [Disconnect] if you want to stop the connection.



- You can connect a maximum of 10 devices.
- When Wi-Fi Direct is active, [Device Name] cannot be changed.
- [Start Group] and [Remove Group] are shown only if Wi-Fi is active and the product is not connected to a Wi-Fi Direct network.
- [Remove Group] is shown if Wi-Fi is active and the product is connected.
- After setting up a start group, the product will be set to the GO (Group Owner) and will wait for a connection request from another device.
- If the product is powered off during a persistent group connection, the group will be started automatically after the product is powered on.

### [Band]

Set the Band.

Enabled only if you have selected [Infrastructure] in the [Mode] menu.



The options are as follows:

- [All]
- [2.4 GHz]
- [5 GHz]

### [SSID]

Set the SSID.

The screen shows the Wi-Fi network detected by the product.

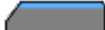
Select the name of the Wi-Fi network you want to connect using the  /  buttons and press the  button to confirm.

To register a Wi-Fi network manually, press the  button and enter the name of the network.

You can enter a maximum of 32 characters. Alphabets (capital and small letters), numbers and symbols can be used.

### [Hidden SSID]

Set the hidden SSID (stealth function).

Appears if you have selected [Infrastructure] in the [Mode] menu.

The options are as follows:

#### Enabled

Enable the hidden SSID.

#### Disabled

Disable the hidden SSID.

### [Mode]

Set the communication method of the wireless LAN.

The options are as follows:

- [Infrastructure]

- [Ad-hoc]

### [Channel]

Set the communication channel.

[Channel] can be set only if you have selected [Ad-hoc] in the [Mode] menu.

The number of channels you can set varies depending on the region of the product.

### [Security]

Set the security method of the network. Set the security methods so that the product, host and network devices match.

The options are as follows:

- [None]
- [WEP]
- [WPA2/WPA]
- [WPA2]
- [Dynamic WEP]

If you have selected [Ad-hoc] in the [Mode] menu, only [None] and [WEP] will be available.

### [WEP Conf.]

Set the WEP key.

Appears if you have selected [WEP] in the [Security] menu.

The setting items are as follows:

### [Authentication]

Set the WEP authentication method.

The options are as follows:

- [Open System]
- [Shared Key]

### [Key Index]

Set the key index.

Set the key index (WEP key) according to the access point of the wireless LAN you connect.

The setting range is from 1 to 4.



- Depending on the connecting device, the range of the key index may be 0 to 3. In such a case, if you have set the product to 1, set the connecting device to 0.
- 

### [Key #1] to [Key #4]

Set the WEP key #1 - key #4.

You can enter alphabets (capital and small letters) and numbers.

Depending on the length of the WEP key, the number of characters you can set is as follows:

- When the key length is 64 bits  
ASCII: Five characters  
Hexadecimal: 10 characters

- When the key length is 128 bits  
ASCII: Thirteen characters  
Hexadecimal: 26 characters

#### [WPA Conf.]

Set the WPA authentication.

Appears only if you have selected [WPA2/WPA] or [WPA2] in the [Security] menu.

The setting items are as follows:

#### [WPA Authentication]

Set the WPA authentication method.

The options are as follows:

- [Personal (PSK)]
- [Enterprise (802.1x)]
- [CKKM]

#### [PSK]

Set the PSK shared key.

Appears only if you have selected [Personal (PSK)] in the [WPA Authentication] menu.

You can enter 8 to 63 ASCII characters or 64 hexadecimal digits. Alphabets, numbers and symbols can be used.

#### [EAP Conf.]

Set the functions for EAP.

Appears only if you have selected items other than [Personal (PSK)] in the [WPA Authentication] menu or if you have selected [Dynamic WEP] in the [Security] menu.

The setting items are as follows:

#### [EAP Mode]

Set the EAP Mode (authentication mode).

The options are as follows:

- [FAST]
- [LEAP]
- [PEAP]
- [TLS]
- [TTLS]

#### [Inner Method]

Set the inner method.

Appears only if you have selected [FAST], [PEAP], or [TTLS] in the [EAP Mode] menu.

- If you have selected [FAST] in the [EAP Mode] menu, the option is [AUTO] only.
- If you have selected [PEAP] in the [EAP Mode] menu, the option is [MSCHAPv2] only.



- If you have selected [TTLS] in the [EAP Mode] menu, the options are [MSCHAPv2], [MSCHAP], [CHAP], and [PAP].

#### [Username]

Set the user name.

You can enter 0 to 63 characters. Alphabets, numbers and symbols can be used.

#### [Password]

Set the password.

You can enter 0 to 32 characters. Alphabets, numbers and symbols can be used.

#### [Anon. Outer ID]

Set the external ID.

Appears if you have selected [FAST], [PEAP], or [TTLS] in the [EAP Mode] menu.

You can enter 0 to 63 characters. Alphabets, numbers and symbols can be used.

#### [Verify Server Cert.]

Enable or disable server certificate validation.

Appears if you have selected anything other than [LEAP] in the [EAP Mode] menu.

The options are as follows:

##### Enabled

Enable server certificate validation.

##### Disabled

Disable server certificate validation.

#### [Private Key P/W]

Set the Private Key password.

Appears only if you have selected [TLS] in the [EAP Mode] menu.

You can enter 0 to 64 characters. Alphabets, numbers and symbols can be used.

#### [PAC Auto Provisioning]

Enable or disable PAC auto provisioning.

Appears if you have selected [FAST] in the [EAP Mode] menu.

The options are as follows:

##### Enabled

Enable PAC auto provisioning.

##### Disabled

Disable PAC auto provisioning.

#### [PAC P/W]

Set the PAC password.

Appears only if you have selected [FAST] in the [EAP Mode] menu and if you have selected [Disabled] in [PAC Auto Provisioning].

You can enter 0 to 64 characters. Alphabets, numbers and symbols can be used.

### [Interface]

Select the network interface.

This item is to select the network interface from LAN or wireless LAN when you have installed the optional wireless LAN.

The options are as follows:

#### Auto

Automatically select between LAN and wireless LAN interface at product startup. LAN is selected if LAN cable is connected to a link-established hub (Link LED is flashing) at product startup.

Wireless LAN is selected if LAN is not detected at product startup.

#### LAN

Use LAN interface (or force LAN interface).

#### Wi-Fi

Use wireless LAN interface (or force wireless LAN interface).

- Appears only if you have installed the optional wireless LAN.



- A message prompting you to restart the product will appear on the Online/Offline screen if you have made any changes. In such a case, reboot the product to apply the settings.
- 

### [Services]

Set the TCP/IP port number, NTP, LPD, FTP, SNMP, or SOS (SATO Online Services).

The setting items are as follows:

### [Ports]

Set the TCP/IP port number.

The setting items are as follows:

#### **Roles of Port1 to Port3**

In the socket server function of TCP/IP, either of the following connection methods can be used.

The ports to be used and their roles change depending on the connection method and communication protocol.

#### **Two-port connection**

Port1 is used for receiving print data, and Port2 is used for returning the product status.

Two-port connection is available when the communication protocol is Status4.

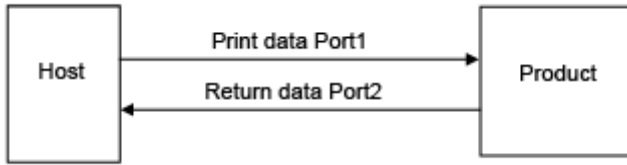

### One-port connection

One port is used for both receiving print data and returning the product status.

When the communication protocol is Status4, Port3 is used.

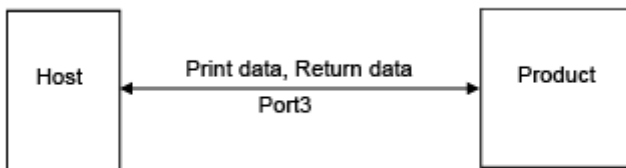

When the communication protocol is Status3 or Status5, Port1 or Port3 is used.

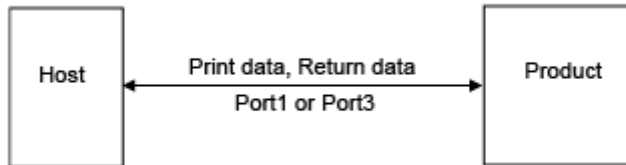

### [Port1]

Set the port number of Port1.

For the two-port connection of Status4, this port is used for receiving print data. For the one-port connection of Status3/Status5, this port is used for both receiving print data and returning the product status.

The setting range is from 1 to 65535.



- Each port (1, 2 and 3) must be set to different values.
- Set a port number not used by other services. If port numbers that overlap with those used by other services are used, communication cannot be performed properly.

### [Port2]

Set the port number of Port2.

For the two-port connection of Status4, this port is used for returning the product status.

The setting range is from 1 to 65535.



- Each port (1, 2 and 3) must be set to different values.
- Set a port number not used by other services. If port numbers that overlap with those used by other services are used, communication cannot be performed properly.



- This setting is disabled when AEP mode is enabled.
- 

### [Port3]

Set the port number of Port3.

For the one-port connection of Status3/Status4/Status5, this port is used for both receiving print data and returning the product status.

The setting range is from 1 to 65535.



- Each port (1, 2 and 3) must be set to different values.
  - Set a port number not used by other services. If port numbers that overlap with those used by other services are used, communication cannot be performed properly.
- 



- You can change the return status format of port3 to Compatible mode by enabling [Legacy Status for Port 9100].
- 

### [Flow Control]

Set the communication protocol.

The options are as follows:

- [Status4]
- [Status4 ENQ]
- [Status3]
- [Status5]
- [None]

### [TCP Connection Queue]

Set whether to allow queuing for connection when multiple hosts or applications are sending connection requests to the product.

The options are as follows:

#### Enabled

While connecting with one host or application, the product can receive connection requests from other hosts or applications. The subsequent connection requests are put on hold, and processed in order of reception after the first connection is closed.

#### Disabled

While connecting with one host or application, the product cannot receive connection requests from other hosts or applications.



- When you have selected [Enabled], be sure to use one port connection for Status3, Status4, and Status5. Operation using two port connections for Status4 is not guaranteed.
- 

### [Legacy Status for Port 9100]

Set whether to change the return status format of Port3 to compatible mode.

Does not appear if you have selected [None] in the [Flow Control] menu.

In compatible mode, the return status format of Port3 becomes as follows:

### STATUS3

Enabled (Compatible mode)

ACK/NAK Reply

ACK/NAK	1 byte
---------	--------

Status Reply

00 00 00 0b	STX	Status3	ETX	15 bytes
-------------	-----	---------	-----	----------

Disabled (Standard mode)

ACK/NAK Reply

ACK/NAK	1 byte
---------	--------

Status Reply

STX	Status3	ETX	11 bytes
-----	---------	-----	----------

### STATUS4

Enabled (Compatible mode)

ACK/NAK Reply

ACK/NAK	1 byte
---------	--------

Status Reply

00 00 00 20	00 00 00 1C	ENQ	STX	Status4	ETX	36 bytes
-------------	-------------	-----	-----	---------	-----	----------

Disabled (Standard mode)

ACK/NAK Reply

00 00 00 01	ACK/NAK	5 bytes
-------------	---------	---------

Status Reply

00 00 00 1C	ENQ	STX	Status4	ETX	32 bytes
-------------	-----	-----	---------	-----	----------

### STATUS5

Enabled (Compatible mode)

ACK/NAK Reply

No Reply

Status Reply

00 00 00 16	STX	Status5	ETX	26 bytes
-------------	-----	---------	-----	----------

Disabled (Standard mode)

ACK/NAK Reply

No Reply

Status Reply

**[ENQ Reply Delay]**

Set the period to delay status reply to status request ENQ.

Not available if you have selected [Status4] in the [Flow Control] menu.

The target interfaces are LAN and Wireless LAN.

The target statuses are Status3, Status4 ENQ reply, and Status5.

The setting range is from 0 to 9999 ms.



- Normally, keep this setting at the default value.
- 

**[Status4 Cyclic Response]**

Set the interval for the cyclic status response.

Available only if you have selected [Status4] in the [Flow Control] menu.

The target interfaces are LAN and Wireless LAN.

The target status is Status4 reply cycle.

The setting range is from 100 to 999 ms.

**[BCC]**

Enable or disable the BCC check function.

Appears only if you have selected [Status5] in the [Flow Control] menu.

The options are as follows:

Enabled

Enable the BCC check function.

Disabled

Disable the BCC check function.

**[NTP]**

Set the functions for NTP.

The NTP function gets the time information from the NTP server through the network and sets the time of the product.

The setting items are as follows:

### [Enable]

Enable or disable the functions for NTP.

The options are as follows:

#### Enabled

Enable the NTP function.

#### Disabled

Disable the NTP function.

### [Error]

Set to show the NTP error message if detected.

The options are as follows:

#### Enabled

Shows the error message.

#### Disabled

Does not show the error message.

### [Time Server IP]

Set the IP address of the NTP server.

The setting range is as follows:

0.0.0.0 to 255.255.255.255

The IP address should normally be set to 0.0.0.0 (the default value). For the default value, the global NTP servers are assigned automatically. Set to a valid IP if the time synchronization is requested for a specific server.

### [LPD]

Set the functions for LPD.

The setting items are as follows:

### [Enable]

Enable or disable the LPD function.

The options are as follows:

#### Enabled

Enable the LPD function.

#### Disabled

Disable the LPD function.

### [DNS Lookup]

Enable or disable the DNS Lookup function.

The options are as follows:

Enabled

Enable the DNS Lookup function.

Disabled

Disable the DNS Lookup function.

**[FTP]**

Set the functions for FTP.

The setting items are as follows:

**[Enable]**

Enable or disable the functions for FTP.

The options are as follows:

Enabled

Enable the FTP function.

Disabled

Disable the FTP function.

**[FTP Timeout]**

Set the connection timeout period between the product's FTP server and clients.

Specify the maximum number of seconds that the product's FTP server will allow clients to stay connected without receiving any data on either the control or data connection.

The setting range is from 10 to 3600 seconds.

**[SNMP]**

Set the functions for SNMP.

The SNMP function enables you to monitor and manage a UDP/IP based network.

The setting items are as follows:

**[sysContact]**

Set the contact information.

You can enter 0 to 255 characters. Alphabets, numbers and symbols can be used.

**[sysName]**

Set the name information.

You can enter 0 to 255 characters. Alphabets, numbers and symbols can be used.

**[sysLocation]**

Set the location information.

You can enter 0 to 255 characters. Alphabets, numbers and symbols can be used.



### [prtMarkerCounterUnit]

Set the unit to use for reporting counter values for subunits.

The options are as follows:

#### impressions

Report the number of printed labels.

#### meters

Report the length of printed labels in meters.

### [Agent]

Set the Agent function.

The setting items are as follows:

#### [Enable]

Enable or disable the functions for Agent.

The options are as follows:

#### Enabled

Enable the functions for Agent.

#### Disabled

Disable the functions for Agent.

### [Read-Only]

Set the read-only function.

The setting items are as follows:

### [SNMP Version]

Set the SNMP version.

The options are as follows:

- [1|2c|3]
- [1|2c]
- [3]
- [Disabled]

### [Community]

Set the read-only community name.

Appears only if you have selected [1|2c|3] or [1|2c] in the [SNMP Version] menu.

You can enter 1 to 32 characters. Alphabets, numbers and symbols can be used.

Initial setting: public

### [User]

Set the read-only user name.

Appears only if you have selected [1|2c|3] or [3] in the [SNMP Version] menu.  
You can enter 1 to 32 characters. Alphabets, numbers and symbols can be used.  
Initial setting: rouser

#### [User Security]

Set the read-only security level.

Appears only if you have selected [1|2c|3] or [3] in the [SNMP Version] menu.

The options are as follows:

- [None]
- [Authentication]
- [Privacy]

#### [Authentication Protocol]

Set the authentication protocol.

Appears only if you have selected [Authentication] or [Privacy] in the [User Security] menu.

The options are as follows:

- [MD5]
- [SHA]

#### [Authentication Passphrase]

Set the authentication passphrase.

Appears only if you have selected [Authentication] or [Privacy] in the [User Security] menu.

You can enter 8 to 32 characters. Alphabets, numbers and symbols can be used.

Initial setting: mypassword

#### [Privacy Protocol]

Set the privacy protocol.

Appears only if you have selected [Privacy] in the [User Security] menu.

The options are as follows:

- [DES]
- [AES]

#### [Privacy Passphrase]

Set the privacy passphrase.

Appears only if you have selected [Privacy] in the [User Security] menu.

You can enter 8 to 32 characters. Alphabets, numbers and symbols can be used.

Initial setting: mypassword

#### [Read-Write]

Set the read-write function.

The setting items are as follows:

#### [SNMP Version]

Set the SNMP version.

The options are as follows:

- [1|2c|3]
- [1|2c]
- [3]
- [Disabled]

#### [Community]

Set the read-write community name.

Appears only if you have selected [1|2c|3] or [1|2c] in the [SNMP Version] menu.

You can enter 1 to 32 characters. Alphabets, numbers and symbols can be used.

Initial setting: private

#### [User]

Set the read-write user name.

Appears only if you have selected [1|2c|3] or [3] in the [SNMP Version] menu.

You can enter 1 to 32 characters. Alphabets, numbers and symbols can be used.

Initial setting: rwuser

#### [User Security]

Set the read-write security level.

Appears only if you have selected [1|2c|3] or [3] in the [SNMP Version] menu.

The options are as follows:

- [None]
- [Authentication]
- [Privacy]

#### [Authentication Protocol]

Set the authentication protocol.

Appears only if you have selected [Authentication] or [Privacy] in the [User Security] menu.

The options are as follows:

- [MD5]
- [SHA]

#### [Authentication Passphrase]

Set the authentication passphrase.

Appears only if you have selected [Authentication] or [Privacy] in the [User Security] menu.

You can enter 8 to 32 characters. Alphabets, numbers and symbols can be used.

Initial setting: mypassword

### [Privacy Protocol]

Set the privacy protocol.

Appears only if you have selected [Privacy] in the [User Security] menu.

The options are as follows:

- [DES]
- [AES]

### [Privacy Passphrase]

Set the privacy passphrase.

Appears only if you have selected [Privacy] in the [User Security] menu.

You can enter 8 to 32 characters. Alphabets, numbers and symbols can be used.

Initial setting: mypassword

### [Traps]

Set the Traps function.

The setting items are as follows:

#### [Enable]

Enable or disable the functions for Traps.

The options are as follows:

##### Enabled

Enable the Traps function.

##### Disabled

Disable the Traps function.

### [SNMP Version]

Set the SNMP version.

The options are as follows:

- [1]
- [2c]
- [3]

### [IP Version]

Set the IP version to use for trap destinations.

The options are as follows:

4

Set the IP version to IPv4.

6

Set the IP version to IPv6.

### **[Destinations]**

Set the number of trap destinations.

The setting range is from 1 to 3.

### **[Destination 1]**

Set address 1 for the trap destination.

The displayed IP version differs depending on the [IP Version] setting.

### **[Destination 2]**

Set address 2 for the trap destination.

The displayed IP version differs depending on the [IP Version] setting.

Appears only if you have selected [2] or [3] in the [Destinations] menu.

### **[Destination 3]**

Set address 3 for the trap destination.

The displayed IP version differs depending on the [IP Version] setting.

Appears only if you have selected [3] in the [Destinations] menu.

### **[Community]**

Set the Traps community name.

Appears only if you have selected [1] or [2c] in the [SNMP Version] menu.

You can enter 1 to 32 characters. Alphabets, numbers and symbols can be used.

Initial setting: trapcom

### **[User]**

Set the Traps user name.

Appears only if you have selected [3] in the [SNMP Version] menu.

You can enter 1 to 32 characters. Alphabets, numbers and symbols can be used.

Initial setting: trapuser

### **[Engine ID]**

Set the engine ID.

Appears only if you have selected [3] in the [SNMP Version] menu.

Initial setting: Created from the MAC address.

Hexadecimal characters are allowed and the range is from 10 to 64 characters. (Only an even number of characters is allowed.)

### **[Security]**

Set the security level.

Appears only if you have selected [3] in the [SNMP Version] menu.

The options are as follows:

- [None]

- [Authentication]
- [Privacy]

#### [Authentication Protocol]

Set the authentication protocol.

Appears only if you have selected [Authentication] or [Privacy] in the [Security] menu.

The options are as follows:

- [MD5]
- [SHA]

#### [Authentication Passphrase]

Set the authentication passphrase.

Appears only if you have selected [Authentication] or [Privacy] in the [Security] menu.

You can enter 8 to 32 characters. Alphabets, numbers and symbols can be used.

Initial setting: mypassword

#### [Privacy Protocol]

Set the privacy protocol.

Appears only if you have selected [Privacy] in the [Security] menu.

The options are as follows:

- [DES]
- [AES]

#### [Privacy Passphrase]

Set the privacy passphrase.

Appears only if you have selected [Privacy] in the [Security] menu.

You can enter 8 to 32 characters. Alphabets, numbers and symbols can be used.

Initial setting: mypassword

#### [Online Services] (SOS users only)

Set the functions for SOS (SATO Online Services).

To use SOS, it is necessary to first create an SOS account and add the product.

For details on the SOS, refer to the SOS portal site.

<https://www.sato-sos.com/en/>

The setting items are as follows:

#### [SOS Mode] (SOS users only)

Select the mode of SOS (SATO Online Services) or disable SOS.

The options are as follows:

##### Disabled

Disables SOS.

### On-Demand

Shows the product information with a QR code. Scan the displayed QR code with a tablet or smartphone and send the information to the SOS cloud. Also, the product information can be acquired via NFC and sent to the SOS cloud. This connection allows you to check the product's operating information via SOS Web. A specialized SOS application is required to scan the QR code or send the product information to the SOS cloud.

### Real-Time

Sends the product information to the SOS cloud in real-time using the LAN/wireless LAN connection. This connection allows you to check the product's operating information and to check or modify the product's settings via SOS Web. Confirm and agree with the Terms of Use to enable the Real-Time mode.

### Light

Sends the product information to the SOS cloud in real-time using the LAN/wireless LAN connection. This connection allows you to check the product's operating information via SOS Web.

## **[Allow Remote Control] (SOS users only)**

Set whether or not to allow setting the product (remote control) from SOS (SATO Online Services).

Appears only if you have selected [Real-Time] in the [SOS Mode] menu.

The options are as follows:

### Deny

Does not allow remote control from SOS.

### Until Reboot

Allows remote control from SOS until the product reboots.

### Always

Always allows remote control from SOS.

## **[MQTT Protocol] (SOS users only)**

Set the communication protocol of MQTT.

Appears only if you have selected [Real-Time] in the [SOS Mode] menu.

The options are as follows:

### MQTT

Set this to use port number 443 and 8883 to do MQTT communication.

### MQTT over WebSocket

Set this to use port number 443 only to do MQTT communication.

## **[MQTT Proxy enabled] (SOS users only)**

Enable or disable the MQTT proxy when using MQTT over WebSocket.

Appears only if you have selected [Real-Time] in the [SOS Mode] menu.

Available only if you have selected [MQTT over WebSocket] for [MQTT Protocol] and if an enabled proxy has been set.

**[Add Device] (SOS users only)**

Shows the serial number and association code that are necessary when adding the product to SOS (SATO Online Services).

Appears only if you have selected something other than [Disabled] in the [SOS Mode] menu.

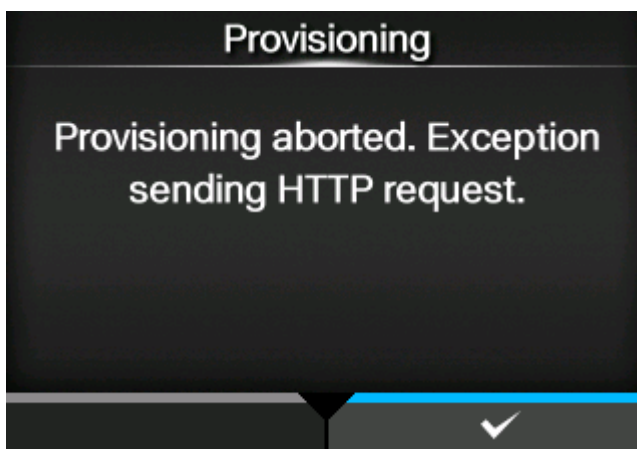

- Regarding the procedure to add a product to SOS, refer to the printer setup manual.  
[https://www.sato-sos.com/en/support/#print\\_preparation\\_manual](https://www.sato-sos.com/en/support/#print_preparation_manual)
- If authentication with the server fails, a screen like the one shown below appears. The message differs depending on the cause. Close the message according to the instructions displayed on the screen and contact your network administrator about the network settings.

**[Contact Information] (SOS users only)**

Shows the SOS (SATO Online Services) contact information that is displayed at the time of the error outbreak.

Available only if you have selected something other than [Disabled] in the [SOS Mode] menu.

The item is as follows:

**Phone Number**

Shows the phone number that is displayed on the error screen.

**[Periodic Notification] (SOS users only)**

Sets the function for periodic SOS (SATO Online Services) notifications.

Appears only if you have selected [On-Demand] in the [SOS Mode] menu.

In this function, the product information is shown periodically with a QR code. Scan the displayed QR code with a tablet or smartphone, and send the information to the SOS cloud.

A specialized application is required to scan the QR code.

The setting items are as follows:

**[Type] (SOS users only)**

Select the timing to perform the periodic notification or disable this function.

Advanced setting items appear on the [Periodic Notification] menu according to the selected options.

The options are as follows:



#### Disabled

Disables the periodic notification function.

#### Daily

Displays the notification screen every day for specified number of times, at the specified time.

#### Weekly

Displays the notification screen every week at the specified day of week and time.

#### Monthly

Displays the notification screen every month at the specified day and time.

#### Counter

Displays the notification screen when the counter of a consumable reaches to the specified value.

#### Offline

Displays the notification screen when the product is changed to Offline mode.

#### **[Counter] (SOS users only)**

Print head is selected for the timing to perform periodic notifications.

Appears only if you have selected [Counter] in the [Type] menu.

#### **[Head] (SOS users only)**

You can specify or check the print distance of the print head for the timing to perform the periodic notification.

Appears only if you have selected [Counter] in the [Type] menu.

The setting items are as follows:

#### Meters

Specifies the print distance of the print head for the timing to perform the periodic notification. You will be notified for every meter you specify.

The setting range is from 1 to 100,000.

#### Last Update

Shows the print distance of the print head for the last periodic notification.

#### Next Update

Shows the print distance of the print head for the next periodic notification.

#### Current Value

Shows the current print distance of the print head.

#### **[Notifications] (SOS users only)**

Specifies the number of periodic notifications to be sent per day.

Appears only if you have selected [Daily] in the [Type] menu.

The setting range is from 1 to 3.

#### [Weekday] (SOS users only)

Specifies the day of the week to perform the periodic notification.

Appears only if you have selected [Weekly] in the [Type] menu.

The setting range is from Sunday to Saturday.

#### [Day] (SOS users only)

Sets the date to perform the periodic notification.

Appears only if you have selected [Monthly] in the [Type] menu.

The setting range is from 1 to 28.

#### [Time 1] (SOS users only)

Specifies the time to perform the first periodic notification.

Appears only if you have selected [Daily] in the [Type] menu.

#### [Time 2] (SOS users only)

Specifies the time to perform the second periodic notification.

Appears only if you have selected [Daily] in the [Type] menu and have set more than two times for [Notifications].

#### [Time 3] (SOS users only)

Specifies the time to perform the third periodic notification.

Appears only if you have selected [Daily] in the [Type] menu and have set three times for [Notifications].

#### [Time] (SOS users only)

Specifies the time of the specified day or date to perform periodic notifications.

Appears only if you have selected [Weekly] or [Monthly] in the [Type] menu.

#### [Update Screen] (SOS users only)

Sets whether to print a QR code displayed with SOS (SATO Online Services) periodic notification or Daily Checkup.

Appears only if you have selected [On-Demand] in the [SOS Mode] menu.

A specialized application is required to scan the QR code.

The options are as follows:

##### Normal

Shows the scan screen of a normal QR code.

##### Print

You can execute printing in the scan screen for the QR code. Press the  button to print the QR code.

To print the QR code, use media of more than 33 mm (1.3") in length and more than 33 mm (1.3") in width (not including the liner).

**[QR code offset] (SOS users only)**

Adjust the print position for printing a QR code displayed on the notification screen for SOS (SATO Online Services).

Appears only if you have selected [On-Demand] in the [SOS Mode] menu.

Available only if you have selected [Print] in the [Update Screen] menu.

The setting items are as follows:

Vertical

Adjust the print position of the QR code in the vertical direction.

Set the correction value from the print reference position as "-" for the direction of the paper feed and "+" for the direction opposite to the paper feed.

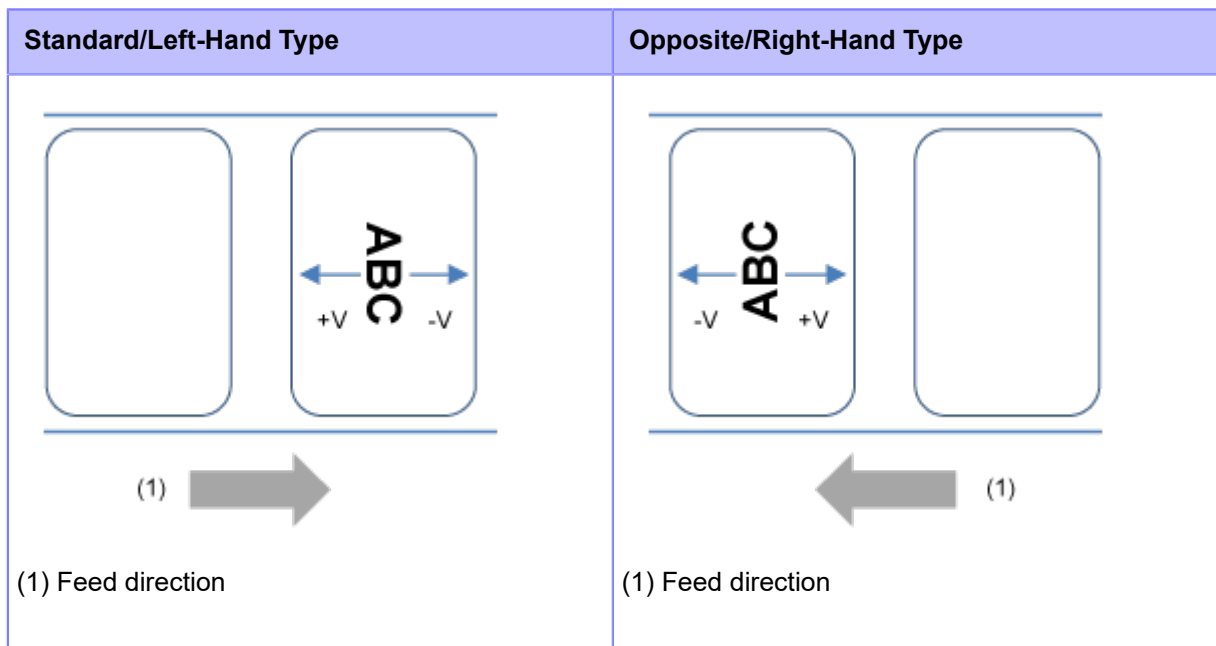

The setting range is from -792 to +792 dots.

Horizontal

Adjust the print position of the QR code in the horizontal direction.

Set the correction value from the print position when facing the product as "-" to adjust to the back side and "+" to adjust to the front side.

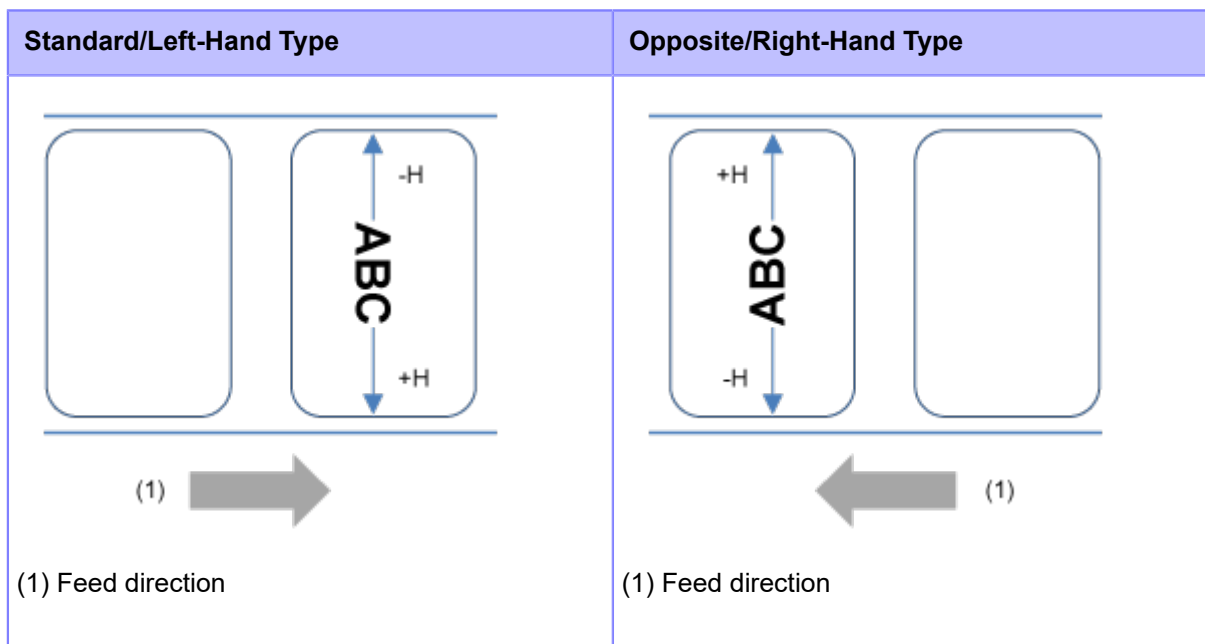

The setting range is from -792 to +792 dots.



- The length of 1 dot varies depending on the print resolution of the product.
  - 203 dpi : 1 dot = 0.125 mm (0.0049")
  - 305 dpi : 1 dot = 0.083 mm (0.0033")
  - 609 dpi : 1 dot = 0.042 mm (0.0017")
- You can change the units to dots, " (inches), or mm in the [System] > [Regional] > [Unit] menu.

### [Daily Checkup] (SOS users only)

Shows the current product information with a QR code. Scan the QR code with a tablet or smartphone, and send it to the SOS cloud.

Also, the product information can be acquired via NFC and sent to the SOS cloud.

Appears only if you have selected [On-Demand] in the [SOS Mode] menu.



A specialized application is required to scan the QR code or send the product information to the SOS cloud.

If you have selected [Print] in the [Update Screen], press the  button to print the QR code.

To print the QR code, use media of more than 33 mm (1.3") in length and more than 33 mm (1.3") in width (not including the liner).

### [Port diagnostic] (SOS users only)

Diagnoses the network environment to determine whether the Real-Time mode and the Light mode can be used when connecting to SOS.

Pressing the  button shows [Are you sure?] on the screen, and then pressing the  button starts the port diagnostic.

The supported mode of the SOS connection appears on the screen when the port diagnostic has been completed.



- The port diagnostic cannot be executed in the following cases:
  - When the default gateway address is not configured
  - When the DNS address is not configured
  - When the firewall setting is enabled

If [Impossible to run.] appears on the screen before starting the port diagnostic, configure each setting in the [Interface] > [Network] menu, and then execute the port diagnostic again.

- If you press the  button (ABORT) during the port diagnostic, the diagnostic will be canceled.
  - If the product fails each test during the port diagnostic, the diagnostic will be canceled. Configure the interface settings according to the message displayed on the screen and contact your network administrator about the network settings.
- 

### [Advanced]

Set the advanced function for the interface.

The setting items are as follows:

### [ARP Announcement]

Set the functions for ARP announcement.

The ARP announcement is useful for updating other hosts mapping of a hardware address when the IP address or MAC address of the sender has changed.

The setting items are as follows:

### [Additional]

Set the additional ARP announcement.

The options are as follows:

#### Enabled

Enable the additional ARP announcement. The ARP is sent at 1, 2, 4, 8 and 16 seconds after the link up/DHCP assignment.

#### Disabled

Disable the additional ARP announcement. The ARP is only sent at 1 second after the link up/DHCP assignment.

### [Periodic]

Set the interval of the ARP announcement in the range of 0 to 600 seconds.

Initial setting: 0

**[Firewall]**

Set the functions for the firewall.

A firewall can improve security. It prevents unauthorized access from external computers or malicious programs. When the firewall is enabled, only the services and ports that are allowed will be able to access the product.



- As a basic policy of filtering, all OUTPUT is allowed (ACCEPT) and both INPUT and FORWARD are not allowed (DROP).
- 

The setting items are as follows:

**[Enable]**

Enable or disable the firewall function.

The options are as follows:

Enabled

Enable the firewall function.

Disabled

Disable the firewall function.

**[Allow Services And Ports]**

Set the service or port to allow communication.

Available only if you have selected [Enabled] in the [Enable] menu.



- The product becomes accessible only through services or ports that are allowed in [Allow Services And Ports].
- 

The setting items are as follows:

Data Ports

Enable or disable access through data ports.

FTP

Enable or disable the functions for FTP.

The setting changes in conjunction with [Enable] in the [FTP] menu.

LPD

Enable or disable the LPD function.

The setting changes in conjunction with [Enable] in the [LPD] menu.

MAILC

When using the AEP (Application Enabled Printing) function, enable or disable port access for the product's internal e-mail client function.

NTP

Enable or disable the functions for NTP.

The setting changes in conjunction with [Enable] in the [NTP] menu.

### Online Services (SOS users only)

Selects the mode for SOS or disable SOS.

The setting changes in conjunction with [SOS Mode].

### PING

Enable or disable PING access.

### SATO All-In-One Tool

Enable or disable the access from SATO All-In-One Tool.

### SCP

When using the AEP (Application Enabled Printing) function, enable or disable port access for the SCP client function.

### SNMP Agent

Enable or disable the SNMP Agent function.

The setting changes in conjunction with [Enable] in the [Agent] menu.

### WEBC

When using the AEP (Application Enabled Printing) function, enable or disable port access for the Web client function.

### WebConfig

Enable or disable access to the web configuration page.

The below table shows the packet filtering setting for each allowed services and port setting.

[Allow Services And Ports]	[TCP Source Port]	[TCP Destination Port]	[UDP Source Port]	[UDP Destination Port]	[ICMP Type]
[Data Ports] *	-	1024,1025,9100	-	-	-
[FTP]	-	20,21	-	-	-
[LPD]	-	515	53	-	-
[MAILC]	465,587	-	53	-	-
[NTP]	-	-	53,123	-	-
[Online Services]*	443,8883	-	53	-	-
[PING]	-	-	-	-	0,8
[SATO All-In-One Tool]	-	9100	-	161,19541	-
[SCP]	22	-	53	-	-
[SNMP Agent]	-	-	-	161	-
[WEBC]	80,443,8080	-	53	-	-

[Allow Services And Ports]	[TCP Source Port]	[TCP Destination Port]	[UDP Source Port]	[UDP Destination Port]	[ICMP Type]
[WebConfig]	-	80,443	-	-	-

\*The values may vary depending on other settings.

### [Custom Settings]

Specify the ICMP type or the port number of TCP or UDP to allow communication.

Available only if you have selected [Enabled] in the [Enable] menu.

The setting items are as follows:

#### [TCP Source Port]

Register the TCP source port number to allow communication.

#### [Existing Port No.]

The port number of the items enabled in [Allow Services And Ports] are shown.

#### [Additional Port No.]

Register the TCP source port number to allow communication.

The acceptable input values are as follows:

Active port number	An integer from 1 to 65535
Specifying multiple values	Delimit active port numbers using a comma “,”
Specifying a range	Create a range of active port numbers using a colon “:” (Input in the order of low port number: high port number)
Maximum number of specifications	21 ports in total by specifying with either numbers or a range
No setting	Blank

#### Input Example

Port number	Comments
10000	-
10000,10001,10002,10003	This results in the same ports in both settings to be allowed.
10000:10003	
10000,10001,10002,10003,20000	This results in the same ports in both settings to be allowed.
10000:10003,20000	



Port number	Comments
Blank	Keep it blank when no setting is needed.

#### [TCP Destination Port]

Register the TCP destination port number to allow communication.

#### [Existing Port No.]

The port number of the items enabled in [Allow Services And Ports] are shown.

#### [Additional Port No.]

Register the TCP destination port number to allow communication.

The acceptable input values are as follows:

Active port number	An integer from 1 to 65535
Specifying multiple values	Delimit active port numbers using a comma “,”
Specifying a range	Create a range of active port numbers using a colon “:” (Input in the order of low port number: high port number)
Maximum number of specifications	21 ports in total by specifying with either numbers or a range
No setting	Blank

#### Input Example

Port number	Comments
10000	-
10000,10001,10002,10003	This results in the same ports in both settings to be allowed.
10000:10003	
10000,10001,10002,10003,20000	This results in the same ports in both settings to be allowed.
10000:10003,20000	
Blank	Keep it blank when no setting is needed.

#### [UDP Source Port]

Register the UDP source port number to allow communication.

#### [Existing Port No.]

The port number of the items enabled in [Allow Services And Ports] are shown.

#### [Additional Port No.]

Register the UDP source port number to allow communication.

The acceptable input values are as follows:

Active port number	An integer from 1 to 65535
Specifying multiple values	Delimit active port numbers using a comma “,”
Specifying a range	Create a range of active port numbers using a colon “:” (Input in the order of low port number: high port number)
Maximum number of specifications	21 ports in total by specifying with either numbers or a range
No setting	Blank

Input Example

Port number	Comments
10000	-
10000,10001,10002,10003	This results in the same ports in both settings to be allowed.
10000:10003	
10000,10001,10002,10003,20000	This results in the same ports in both settings to be allowed.
10000:10003,20000	
Blank	Keep it blank when no setting is needed.

#### [UDP Destination Port]

Register the UDP destination port number to allow communication.

#### [Existing Port No.]

The port number of the items enabled in [Allow Services And Ports] are shown.

#### [Additional Port No.]

Register the UDP destination port number to allow communication.

The acceptable input values are as follows:

Active port number	An integer from 1 to 65535
Specifying multiple values	Delimit active port numbers using a comma “,”
Specifying a range	Create a range of active port numbers using a colon “:” (Input in the order of low port number: high port number)
Maximum number of specifications	21 ports in total by specifying with either numbers or a range
No setting	Blank

#### Input Example

Port number	Comments
10000	-
10000,10001,10002,10003	This results in the same ports in both settings to be allowed.
10000:10003	
10000,10001,10002,10003,20000	This results in the same ports in both settings to be allowed.
10000:10003,20000	
Blank	Keep it blank when no setting is needed.

#### [ICMP Type]

Register the ICMP type to allow communication.

#### [Existing ICMP Type]

The ICMP type number of the items enabled in [Allow Services And Ports] are shown.

#### [Additional ICMP Type]

Register the ICMP type number to allow communication.

The acceptable input values are as follows:

Active ICMP type	An integer from 0 to 43
Specifying multiple values	Delimit active ICMP types using a comma “,”
Maximum number of specifications	44 ports
No setting	Blank

#### Input Example

ICMP type	Comments
0	-
0,1,2,3	-
Blank	Keep it blank when no setting is needed.

#### [RS-232C]

Set the RS-232C connection.



- When [Tools] > [Barcode Checker] > [Test] > [Interface] is set to [RS-232C Reader], the following message appears on the screen and you cannot change the [RS-232C] menus.

"Reader is set for RS232C connection destination. Please check the setting of barcode checker."

---

The setting items are as follows:

### [Baudrate]

Set the baudrate (bps).

Available to change only if you have selected [RS-232C] in the [Tools] > [Barcode Checker] > [Test] > [Interface] menu.

The options are as follows:

- [2400]
- [4800]
- [9600]
- [19200]
- [38400]
- [57600]
- [115200]

### [Parameters]

Set the data parameters.

Available to change only if you have selected [RS-232C] in the [Tools] > [Barcode Checker] > [Test] > [Interface] menu.

The options are as follows:

Refer to the table below for the parameter configurations.

- [8-N-1]
- [8-O-1]
- [8-E-1]
- [8-N-2]
- [8-O-2]
- [8-E-2]
- [7-N-1]
- [7-O-1]
- [7-E-1]
- [7-N-2]
- [7-O-2]
- [7-E-2]

### Parameter Configurations List

Parameters	Data length (bit)	Parity	Stop bit (bit)
8-N-1	8	NONE	1
8-O-1	8	ODD	1
8-E-1	8	EVEN	1
8-N-2	8	NONE	2
8-O-2	8	ODD	2
8-E-2	8	EVEN	2
7-N-1	7	NONE	1
7-O-1	7	ODD	1
7-E-1	7	EVEN	1
7-N-2	7	NONE	2
7-O-2	7	ODD	2
7-E-2	7	EVEN	2

### [Flow Control]

Set the communication protocol.

Available to change only if you have selected [RS-232C] in the [Tools] > [Barcode Checker] > [Test] > [Interface] menu.

The options are as follows:

- [READY/BUSY Multi]
- [XON/XOFF Multi]
- [STATUS3]
- [STATUS4]
- [STATUS5]
- [None]

### [BCC]

Enable or disable the BCC check function.

Appears only if you have selected [RS-232C] in the [Tools] > [Barcode Checker] > [Test] > [Interface] menu and if you have selected [STATUS5] in the [Flow Control] menu.

The options are as follows:

#### Enabled

Enable the BCC check function.

Disabled

Disable the BCC check function.

**[USB]**

Set the USB connection.

The setting items are as follows:

**[Flow Control]**

Set the communication protocol.

The options are as follows:

- [Status4]
- [Status5]
- [None]

**[BCC]**

Enable or disable the BCC check function.

Appears only if you have selected [Status5] in the [Flow Control] menu.

The options are as follows:

Enabled

Enable the BCC check function.

Disabled

Disable the BCC check function.

**[Change USB Serial]**

Set the type of the USB serial number that the product returns.

The options are as follows:

Enabled

Returns the USB serial number (00000000).

This option is suitable when you want to replace the product without adding a new printer driver.

To do so, you need to set this setting to enabled before installing the product.

Disabled

Returns the factory set USB serial number (unique to each product).

This option is suitable when you want to set the printer driver for each product.



- If two products that have the same USB serial number connected to the same computer, it may cause the computer to show a blue screen error.
-

## [NFC]

Sets the NFC connection.

The setting item is as follows:

### [I/F Enable]

Enables or disables the NFC interface.

The options are as follows:

#### Enabled

Enables the NFC interface.

#### Disabled

Disables the NFC interface.

## [Ignore CR/LF]

Set whether to ignore the CR/LF code (0x0D / 0x0A) in the received data.

The options are as follows:

#### Enabled

Ignore the CR/LF code.

#### Disabled

Do not ignore the CR/LF code.

## [Ignore CAN/DLE]

Set whether to ignore the CAN/DLE code (0x18 / 0x10) in the received data.

The options are as follows:

#### Enabled

Ignore the CAN/DLE code.

#### Disabled

Do not ignore the CAN/DLE code.

## [External I/O]

Use the external (EXT) terminal as an interface between the external device and the product.

The setting items are as follows:

## [Print Start Signal]

Printing starts if the Print Start signal (PRIN) is detected when the print data is available in Online mode.

The setting items are as follows:

### [Enable]

Enable or disable the Print Start signal (PRIN).

If you have selected [Dispenser], [Linerless], or [Dispense & Print] in the [Printing] > [Print Mode] menu, the setting is fixed as [Enabled].

The options are as follows:

#### Enabled

Enable the Print Start signal (PRIN).

#### Disabled

Disable the Print Start signal (PRIN).

### [PIN]

Assign the pin number for the Print Start signal (PRIN) input.

Appears only if you have selected [Enabled] in the [Enable] menu.

The options are as follows:

#### PIN8

Assign Pin 8 to the Print Start signal (PRIN).

#### PIN20

Assign Pin 20 to the Print Start signal (PRIN).

#### AEP

Print starts when a request is sent from the AEP application.

### [Signal State]

Select the signal state to assign.

Appears only if you have selected an item other than [AEP] in [PIN].

The options are as follows:

- [Falling Edge]
- [Rising Edge]
- [Active Low]
- [Active High]

### [EXT I/O Re-print]

Prints the previously printed content again if the Reprint signal is detected when the print data is not available in Online mode.

The setting items are as follows:



### [Enable]

Set the reprint function that uses the external terminal.

Appears only if [Print Start Signal] > [Enable] is enabled.

The options are as follows:

#### Enabled

Enable the reprint function.

#### Disabled

Disable the reprint function.

### [PIN]

Assign the pin number for the Reprint signal input.

Appears only if you have selected [Enabled] in the [Enable] menu.

The options are as follows:

#### PIN8

Assign Pin 8 to the Reprint signal.

#### PIN20

Assign Pin 20 to the Reprint signal.

### [Signal State]

Select the signal state to assign.

The options are as follows:

- [Falling Edge]
- [Rising Edge]
- [Active Low]
- [Active High]

### [Continuous Print]

When this is enabled, reprint can be executed via the Print Start signal (PRIN).

Reprint can be executed either by enabling this setting or by the PIN assigned to the Reprint signal.

Appears only if you have selected [Enabled] in the [Enable] menu.

The options are as follows:

#### Enabled

Enable the continuous print function.

#### Disabled

Disable the continuous print function.

### [Enhanced Reprint]

When this is enabled, the data that was just printed is reprinted even when the print data remains.

Appears only if you have selected [Enabled] in the [Enable] menu.

The options are as follows:

Enabled

Enable the enhanced reprint function.

Disabled

Disable the enhanced reprint function.

## [Signals]

Assign to the input/output signals to the pin number.



- Do not assign the same function to multiple pin numbers when you are assigning input signal and output signal functions to pin numbers.
- 

The setting items are as follows:

## [Inputs]

Assign the input signals to the pin number.

Select the pin to assign the signal.

The available pins are as follows:

### [PIN7]/[PIN9]/[PIN10]/[PIN21]/[PIN22]/[PIN23]

The setting items are as follows:

#### [Function]

Select the function to assign.

The options are as follows:

Label Near End

The product becomes label near end status when a signal is detected.

Feed

Media feeds when a signal is detected.

Cancel

Cancels print data when a signal is detected.

Online/Offline

Switches Online/Offline modes when a signal is detected.

Dispense In

When [Backfeed] in the [Printing] menu is set to [Controlled], backfeed is performed when a signal is detected.

Unassigned

No signal is assigned.

## [Signal State]

Select the signal state to assign.

Appears only if you have selected an item other than [Unassigned] in [Function].

The options vary depending on the function set in [Function].

If you have selected [Label Near End] or [Feed] in [Function]:

- [Active Low]
- [Rising Edge]

If you have selected [Cancel], [Online/Offline] or [Dispense In] in [Function]:

- [Falling Edge]
- [Active High]

## [Outputs]

Assign the output signals to the pin number.

Select the pin to assign the signal.

The available pins are as follows:

[PIN3]/[PIN4]/[PIN5]/[PIN6]/[PIN16]/[PIN17]/[PIN18]/[PIN19]

The setting items are as follows:

### [Function]

Select the function to assign.

The options are as follows:

#### Paper End

Outputs a signal when the paper end is detected.

#### Ribbon End

Outputs a signal when the ribbon end is detected.

#### Machine Error

Outputs a signal when an error, such as a cover open, head error, or communication error is detected.

#### Print Done

Outputs a signal when printing is complete.

#### Print Ready

Outputs a signal when the product is in Online mode and ready for printing.

#### Online

Outputs a signal when the product is in Online mode.

#### Data Present

Outputs a signal when print data is available.

#### Ribbon Near End

Outputs a signal when the ribbon near end is detected.

Home Position

Outputs a signal when [Backfeed] in the [Printing] menu is set to [Controlled] and backfeed is done.

Paper End/Ribbon End

Outputs a signal when the paper end or the ribbon end is detected.

Machine Error/RFID Error (If RFID mode is enabled) (S84NX only)

Outputs a signal when an error, such as cover open, head error, or communication error, is detected.

Or, outputs a signal when an RFID system error occurs.

RFID error (If RFID mode is enabled) (S84NX only)

Outputs a signal when an RFID system error occurs.

RFID Tag Error (If RFID mode is enabled) (S84NX only)

Outputs a signal when an RFID tag error occurs.

BCR Error

Outputs a signal when a barcode reading/comparison error is detected.

AEP

Outputs a signal for AEP (Application Enabled Printing).

Unassigned

No signal is assigned.

**[Signal State]**

Select the signal state to assign.

Appears only if you have selected an item other than [Unassigned] or [AEP] in [Function].

The options vary depending on the function set in [Function].

If you have selected [Print Done] in [Function]:

- [TYPE1]
- [TYPE2]
- [TYPE3]
- [TYPE4]

If you have selected an item other than [Print Done] in [Function]:

- [Active Low]
- [Active High]

**[RFID] (S84NX Only)**

Set the RFID.

Appears only for the RFID model.



- To use the RFID option, use a firmware version that is later than 8.1.0.
-

The setting items are as follows:

#### [Antenna Position]

Follow the Inlay Configuration Guide to select an RFID antenna to use. For details, access the following URL:

<https://www.sato-global.com/rfid/guide.html>

To use inlays that are not in the Inlay Configuration Guide, contact your SATO sales representative or reseller.

The options are as follows:

##### Normal

Use a standard antenna (adjustable).

##### Front

Use a short pitch antenna (fixed position).

#### [Write Power]

Set radio power level used to write information to inlay according to the Inlay Configuration Guide. For details, access the following URL:

<https://www.sato-global.com/rfid/guide.html>

To use inlays that are not in the Inlay Configuration Guide, contact your SATO sales representative or reseller.

The setting range is from 0 to 30 dBm.

The setting range differs depending on where the product is being operated.

#### [Read Power]

Set radio power level used to read information from inlay according to the Inlay Configuration Guide. For details, access the following URL:

<https://www.sato-global.com/rfid/guide.html>

To use inlays that are not in the Inlay Configuration Guide, contact your SATO sales representative or reseller.

The setting range is from 0 to 30 dBm.

The setting range differs depending on where the product is being operated.

#### [Tag Offset]

Set the position at which to start writing data to the inlay. Data is written to an inlay on each tag at the point where the inlay passes over the product's RFID antenna, which is at the distance, from the print start position, specified in this setting.

This setting will be used when inlays are not compatible with the product's antenna positions. For details, access the following URL:

<https://www.sato-global.com/rfid/guide.html>

To use inlays that are not in the Inlay Configuration Guide, contact your SATO sales representative or reseller.

The setting range is from -15 to 240 mm (-0.59 to 9.45").

The minimum value is 0 mm (0") if other than [Continuous] is selected in the [Printing] > [Print Mode] menu.

### [Reader Model]

Shows the RFID module model.

### [Reader Version]

Shows the RFID module firmware version.

### [View]

Shows the inlay data.

Press the  button to change to the [Memory Bank] screen.

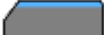
Press the  button (READ) to change to the [Data Reading] screen, to read and show the data.

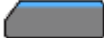
On the [Data Reading] screen, you can press the  button to feed the media and attempt to read the tag currently set in the product.

When no inlay has been detected, "Tag not found" appears on the screen. When multiple inlays have been detected at the same time, "Multiple tags error" appears on the screen.

### [Memory Bank]

Set the memory area of the inlay to read.

The readable memory areas are as follows:

#### EPC

EPC area

#### TID

TID area

#### USER

USER area

#### PC

PC/AFI area

#### RSSI

RSSI area

### [Filter Function]

Set the filter function by RSSI (Received Signal Strength Indication). If the RSSI value read while printing an RFID tag is lower than the specified threshold value, an RFID tag error occurs. An error message is printed on the inlay/RFID tag that caused the error.

The setting items are as follows:

### [RSSI Filter]

Enable or disable the RSSI filter function.

The options are as follows:

### Enabled

Enable the RSSI filter function.

### Disabled

Disable the RSSI filter function.

### [Threshold Value]

Set the threshold value for the RSSI filter.

Appears only if [Enabled] is selected in the [RSSI Filter] menu.

The setting range is from -99 to -1 dBm.

### [Retry Mode]

Set whether to retry encoding of failed data when an RFID error occurs.

The options are as follows:

#### Retry

If an RFID error occurs, the product will retry writing according to the number of times of [Retries]. If the RFID errors occur consecutively, printing stops after the number of retries in [Retries] plus one more retry occur, and the RFID error screen opens.

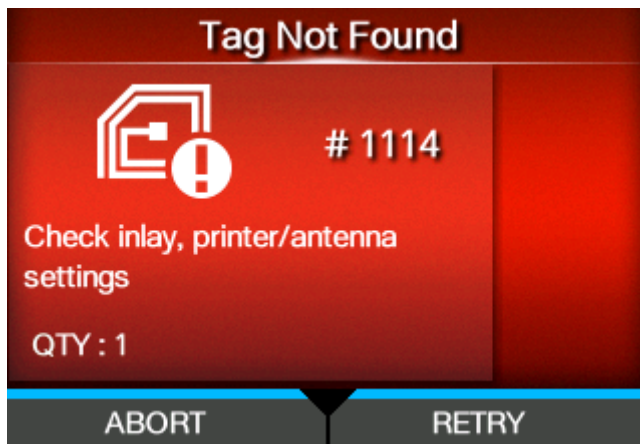

Pressing the  button (RETRY) retries writing the number of times in [Retries].

Pressing the  button (ABORT) deletes one current item.

#### Release

If an RFID error occurs, the next data is written, without trying to write the same data again. If the RFID errors occur consecutively, printing stops after the number of retries in [Retries] occurs, and the RFID error screen opens.

Pressing the  button (RETRY) deletes one copy of the current print data, and then starts printing the next.

Example:

- If one copy each of 10 items are being printed, the current item is deleted, and the remaining items are printed.
- If 10 copies of one item are being printed, the current print data is deleted, and the remaining copies are printed.

Pressing the  button (ABORT) deletes the one current item, and then starts printing the next.

Example:

- If one copy each of 10 items are being printed, the current item is deleted, and the remaining items are printed.
- If 10 copies of one item are being printed, the current item is deleted, and then printing stops.



- To cancel an entire print job, open and close the top cover to switch the product to Offline mode, and then press the  button (CANCEL).
- 

### [Retries]

Set the number of times the retry/release operations as set in [Retry Mode] are repeated before printing stops and the RFID error screen opens, when an RFID error occurs.

The setting range is from 0 to 9.

If you set to 0, the RFID error screen appears and printing continues.

### [Mark bad tags]

Set the error print for the RFID tag error.

#### Enabled

Enable the RFID error print function.

#### Disabled

Disable the RFID error print function.

### [RFID Undetected Warning]

To prevent wasting RFID tags, set whether to stop printing and display an RFID undetected warning error if there is no RFID command in the print job.

The RFID commands that are detected by this function are EPC code write <IP0> and UID/EPC/IDm print <TU> commands.

The options are as follows:

#### Disable

The RFID undetected warning error is not displayed. Printing continues.

#### RFID Tag

Printing stops and an RFID undetected warning error is displayed if there is no RFID command in the print job when an RFID tag is loaded.

The error is no longer displayed if the media is replaced with normal labels.

#### RFID Command

Printing stops and an RFID undetected warning error is displayed if there is no RFID command in the print job.





- An RFID undetected warning is displayed even when using an RFID command that is intended to be detected in the print job, if it is written in the data that caused the command error.
- 

### [Log RFID Data]

Set the log function to record the encoded tag information.

The log data can record up to 100 inlays of information. When the log file reaches its maximum size, the new log data overwrites the older log data.

All the log data will be lost if the product is powered off.

The options are as follows:

#### Enabled

Enable the log function to record the RFID data.

#### Disabled

Disable the log function to record the RFID data.

### [Data To Record]

Set the data to record the log when [Log RFID Data] is enabled.

The options are as follows:

#### EPC and TID

Store the EPC and TID data.

#### EPC

Store the EPC data.

#### TID

Store the TID data.

### [Output Error Mode]

Set the signal type for RFID errors.

The options are as follows:

#### Pulse

Outputs a pulse as the output signal when an RFID error occurs.

#### Level

Outputs a level as the output signal when an RFID error occurs.

### [Pulse Length]

Set the length of an RFID error pulse.

Appears only if you have selected [Pulse] in the [Output Error Mode] menu.

The options are as follows:

- [100 ms]
- [200 ms]
- [300 ms]
- [400 ms]
- [500 ms]

### [Counters]

Shows the RFID counter.

RFID writing operations by the following commands are counted.

- RFID write: EPC code write <IP0> command
- Tag data print: UID/EPC/IDm print <TU> command

However, writing that is not accompanied by printing and media feeding is not counted.

The display items are as follows:

### [Life]

Shows the number of RFID write successes, failures, and total attempts.

The display items are as follows:

#### Count Success

Shows the total number of successful times you have written to an RFID tag.

#### Count Failure

Shows the total number of RFID write errors.

#### Count Total

Shows the total number of times you have written to an RFID tag.

This is the total number including [Count Success] and [Count Failure].

### [User]

Shows the number of RFID write successes, failures, and total attempts after the RFID counter is cleared.

The display items are as follows:

#### Count Success

Shows the total number of successful times you have written to an RFID tag after the RFID counter is cleared.

#### Count Failure

Shows the total number of RFID write errors after the RFID counter is cleared.

#### Count Total

Shows the total number of times you have written to an RFID tag after the RFID counter is cleared.

This is the total number including [Count Success] and [Count Failure].



- You can reset the counter pressing the  button ([CLEAR]) when the counter is 1 or higher.
- 

## [Paper]

Set the paper type of RFID tags and the print reference position in the vertical direction.

The setting items are as follows:

## [Types]

Set the paper type of RFID tags.

The options are as follows:

### Label

Use normal RFID tags.

### Side Hole Tag

Use side hole tags.

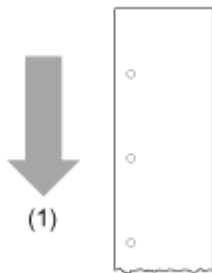

(1) Media feed direction

## [Starting Point]

Set the print reference position of RFID tags in the vertical direction.

Set the print reference position as "+" for the direction of the paper feed and "-" for the direction opposite to the paper feed.

The setting range is from -600 to +600 dots.



- When the direction of the paper feed is set to "+", the total length including other pitch values should not exceed 25 mm (0.98"). If it exceeds 25 mm (0.98"), the product may not stop properly.
- 



- The length of 1 dot varies depending on the print resolution of the product.
  - 203 dpi : 1 dot = 0.125 mm (0.0049")
  - 305 dpi : 1 dot = 0.083 mm (0.0033")
  - 609 dpi : 1 dot = 0.042 mm (0.0017")

- You can change the units to dots, " (inches), or mm in the [System] > [Regional] > [Unit] menu.

### [RFID Tag Model]

Register, edit, read, and delete RFID tag models. The RFID tag model is a registered combination of the optimal antenna position, writing/reading power, and tag offset value for each type of RFID tag.

You can register a maximum of 10 RFID tag models.

The setting items are as follows:

#### [Load]

Read a registered RFID tag model and apply the settings to the product.

You can use this if more than one RFID tag model has been registered.

Select the RFID tag model and press the  button to read, and then press the  button in the confirmation message.

The name of the RFID tag model that was read appears on the right side of [Load] on the [RFID Tag Model] menu.

#### [Edit]

Register a new RFID tag model or edit registered RFID tag models.

To edit registered RFID tag models, read the targeted RFID tag model in advance in the [Load] menu.

For information needed for these settings, refer to the Inlay Configuration Guide. To view the Inlay Configuration Guide, access the following URL:

<https://www.sato-global.com/rfid/guide.html>

To use inlays that are not in the Inlay Configuration Guide, contact your SATO sales representative or reseller.

The setting items are as follows:

Antenna Position

Write Power

Read Power

Tag Offset

Pitch Size

Set the length of the RFID tag.

The setting range varies depending on the print resolution of the product.

The setting range of the RFID tag length is as follows:

Resolution	Setting range
203 dpi (1 dot = 0.125 mm (0.0049"))	8 to 1920 dots
305 dpi (1 dot = 0.083 mm (0.0033"))	12 to 2880 dots
609 dpi (1 dot = 0.042 mm (0.0017"))	24 to 5760 dots

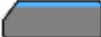

- You can change the units to dots, " (inches), or mm in the [System] > [Regional] > [Unit] menu.
  - Set a value that includes the liner.
- 

When the settings are complete, select [Save as], press the  button, and input a name.

You can enter a maximum of 32 characters. Alphabets, numbers and symbols can be used.

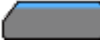
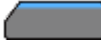

After inputting a name, press the  button, and press the  button in the confirmation screen to confirm.

If you specify a name that is the same as a registered RFID tag model, a confirmation message appears. To overwrite the settings, press the  button.

### [Delete]

Delete registered RFID tag models.

You can use this if more than one RFID tag model has been registered.

Select the RFID tag model to delete and press the  button, and then press the  button in the confirmation message.



## [Applications] Menu

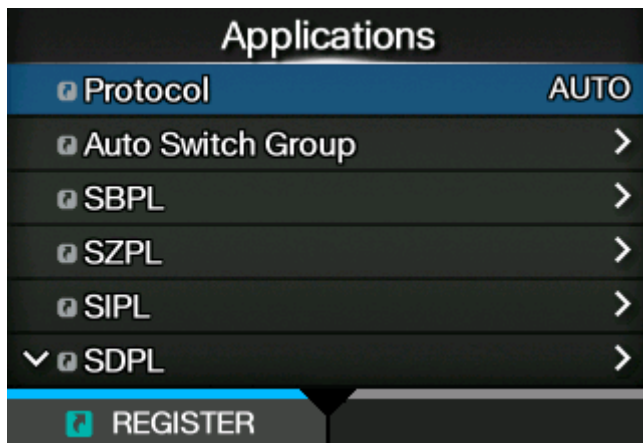

The following settings are available in the [Applications] menu:

### [Protocol]

Set the printer language.

The options are as follows:

#### AUTO

Automatically analyze the received print data and set the printer language. In [AUTO] mode, the product can change the language after startup by receiving another language.

#### SBPL

Set when you use the SBPL printer language or XML.

#### SZPL

Set when you use the SZPL printer language.

#### SIPL

Set when you use the SIPL printer language.

#### SDPL

Set when you use the SDPL printer language.



(When [AUTO] is selected in the [Protocol] menu)

- A message prompting you to restart the product will appear on the Online/Offline screen if you select [AUTO]. In such a case, reboot the product to apply the settings.

- Once the printer language is set, the name of the printer language will appear on the Online/Offline screen.



- Printer language is finalized with the received print data.
- When [SBPL] > [Standard Code] in the [Applications] menu is disabled, the [Protocol] setting will be changed to [SBPL].

### [Auto Switch Group]

Set the printer languages to switch automatically.

Appears only if you have selected [AUTO] in the [Protocol] menu.



- The printer language set in [AUTO] mode is grayed out.

The options are as follows:

### [SBPL]

Enable or disable the SBPL printer language.

The options are as follows:

Enabled

Enable the SBPL printer language.

Disabled

Disable the SBPL printer language.

[SZPL]

Enable or disable the SZPL printer language.

The options are as follows:

Enabled

Enable the SZPL printer language.

Disabled

Disable the SZPL printer language.

[SIPL]

Enable or disable the SIPL printer language.

The options are as follows:

Enabled

Enable the SIPL printer language.

Disabled

Disable the SIPL printer language.

[SDPL]

Enable or disable the SDPL printer language.

The options are as follows:

Enabled

Enable the SDPL printer language.

Disabled

Disable the SDPL printer language.

[SBPL]

SBPL (SATO Barcode Printer Language) is the common command that controls SATO barcode label printers.

To use SBPL as a printer command, set the following items:



### [Show Error]

Enable or disable the command error indication when incorrect command or parameter is detected in the print data.

The options are as follows:

#### Enabled

The command error is shown and the printing operation is paused when incorrect commands or parameters are detected in the print data.

#### Disabled

Ignores incorrect commands or parameters and continues printing operations. The status icon for command error is displayed.

### [Standard Code]

Set the protocol code.

The options are as follows:

#### Enabled

Use a standard code.

#### Disabled

Use a non-standard code.



- A message prompting you to restart the product will appear on the Online/Offline screen if you have made any changes. In such a case, reboot the product to apply the settings. When [AUTO] is selected in the [Protocol] menu while [Disabled] is selected, the setting will be changed to [Enabled].
- 

### [Orientation]

Select the layout for printing the label.

#### Portrait

Use a portrait layout. (No rotation)

#### Landscape

Use a landscape layout. (90-degree rotation)

#### Inv. Portrait

Use an inverse portrait layout. (180-degree rotation)

#### Inv. Landscape

Use an inverse landscape layout. (270-degree rotation)

### [Font Settings]

Set the font.

The setting items are as follows:

**[Zero Slash]**

Set whether to print the number zero (0) with or without a slash (/).

This setting is applied to the following bitmap fonts:

U, S, M, WB, WL, XU, XS, XM, XL, X20, X21, X22, X23, X24

The options are as follows:

Enabled

Print zero with a slash.

Disabled

Print zero without a slash.

**[Kanji]**

Set the kanji code to be used.

The setting items are as follows:

**[Kanji Set]**

Set the kanji code to be used.

The options are as follows:

- [JP-COMPATIBLE]
- [JP-JISX0208]
- [JP-JISX0213]
- [GB18030]
- [BIG5]
- [KSC5601]

**[Character Code]**

Set the character code to be used.

The options vary depending on the kanji code set in the [Kanji Set]:

- **When set to [JP-COMPATIBLE] or [JP-JISX0208]**
  - [JIS]
  - [SJIS]
  - [UTF-16]
  - [UTF-8]
- **When set to [JP-JISX0213]**
  - [SJIS]
  - [UTF-16]
  - [UTF-8]
- **When set to [GB18030]**

- [GB18030]
- [UTF-8]
- **When set to [BIG5]**
  - [BIG5]
  - [UTF-8]
- **When set to [KSC5601]**
  - [KSC5601]
  - [UTF-8]

### [Kanji Style]

Set the font to be used.

The options are as follows:

- [Mincho]
- [Gothic]

### [Proportional]

Set whether to print each character using a proportional pitch or fixed pitch.

The options are as follows:

#### Enabled

Print each character with a proportional pitch.

#### Disabled

Print all characters with a fixed pitch.

### [Code Page]

Select the code page to be used from the list.

### [€]

Set the European currency symbol to the ASCII code.

The setting range is from 00 to ff (hexadecimal).

### [Compatible]

Set the compatible code for SBPL.

The setting items are as follows:

### [M-8400 Compatibility]

Enable or disable the M-8400 printer compatibility function.

The options are as follows:

Enabled

Enable the M-8400 printer compatibility function.

Disabled

Disable the M-8400 printer compatibility function.



- Contact your SATO sales representative for more information about the M-8400 printer compatibility function.
  - If [M-8400 Compatibility] is set to [Enabled], [CODE128(C) Zero Fill] is automatically enabled and the setting item does not appear.
- 

**[CODE128(C) Zero Fill]**

Set whether to allow odd digits and print the barcode with zero-filling at the end of the data when start code C is used in CODE128.

If [M-8400 Compatibility] is set to [Enabled], this setting is automatically enabled and does not appear.

The options are as follows:

Enabled

Allow odd digits and print the barcode with zero-filling.

Disabled

Do not allow odd digits. A command error occurs and the barcode will not be printed.

**[Kanji Command]**

Set the product behavior when the received data includes the Kanji command ESC+K5, ESC+K6 or ESC+K7.

The options are as follows:

Enabled

Change the Kanji commands ESC+K5, ESC+K6 and ESC+K7 in the received data to the proper commands and print.

- ESC+K5: 16x16 dots Kanji in horizontal line with one-byte character
- ESC+K6: 24x24 dots Kanji in horizontal line with one-byte character
- ESC+K7: 22x22 dots Kanji in horizontal line

Disabled

Do not change the Kanji commands ESC+K5, ESC+K6 and ESC+K7 in the received data. The product behavior when it receives these commands is as follows:

- ESC+K5: Print with 40x40 dots Kanji in horizontal line.
- ESC+K6: A command error occurs and the data will not be printed.
- ESC+K7: A command error occurs and the data will not be printed.

### [Call Font/Logo]

Set how to process the character code specified in Recall font & logo command (ESC+RF).

The options are as follows:

#### Enabled

Character codes are processed in little-endian format.

#### Disabled

Character codes are processed in big-endian format.

### [A3 Command Save(S-type)]

Set whether to save all values (with or without +/- sign) specified by the Base Reference Point command ESC+A3 to the product's [Imaging] menu.

The options are as follows:

#### Enabled

All values (with or without +/- sign) specified by the command ESC+A3 are saved to the product's [Imaging] menu.

#### Disabled

Only values without +/- sign specified with the command ESC+A3 are saved to the product's [Imaging] menu. Values with +/- sign are not saved.

### [PDF417 ECC Level fixed]

Set whether to print the PDF417 code with the security level specified by the PDF417 printing command.

The options are as follows:

#### Enabled

Print the PDF417 code with the security level specified by the PDF417 printing command.

#### Disabled

Print the PDF417 code with the security level specified by the PDF417 (or higher) printing command.

### [Head Size] (S86NX Only)

Set the compatible mode in relation to the head size.

The options vary depending on the print resolution of the product.

The options are as follows:

Resolution	Option	Head Width
203 dpi (1 dot = 0.125 mm (0.0049"))	[Normal]	167.5 mm (6.59")
	[M8460Se]	152.0 mm (5.98")
	[M8485Se]	128.0 mm (5.04")

Resolution	Option	Head Width
305 dpi (1 dot = 0.083 mm (0.0033"))	[Normal]	167.5 mm (6.59")
	[M8465Se]	152.0 mm (5.98")

**[Darkness]**

Set the compatible mode used by the print darkness ESC+#E command.

The options are as follows:

Disabled

The print darkness ESC+#E command is ignored.

M8485/90/60/65Se

The print darkness level that is acquired by the [DC2]PB command and the print darkness level that is displayed on screen become 3 times the value set by the ESC+#E command.

S84/M8459Se

The print darkness level that is acquired by the [DC2]PB command and the print darkness level that is displayed on screen become 2 times the value set by the ESC+#E command.

**[SZPL]**

To use SZPL as a printer command, set the following items:

**[Label]**

Set the print position.

The setting items are as follows:

**[Shift]**

Set the shift offset position of the label.

The setting range varies depending on the print resolution of the product.

The setting range is as follows:

Resolution	S84NX	S86NX
203 dpi (1 dot = 0.125 mm (0.0049"))	-832 to 0 to 832 dots	-832 to 0 to 832 dots
305 dpi (1 dot = 0.083 mm (0.0033"))	-1248 to 0 to 1248 dots	-1248 to 0 to 1248 dots
609 dpi (1 dot = 0.042 mm (0.0017"))	-2496 to 0 to 2496 dots	-



- You can change the units to dots, " (inches), or mm in the [System] > [Regional] > [Unit] menu.
- 

### [Top]

Set the top offset position of the label.

The setting range is from -120 to +120 dots.

---



- The length of 1 dot varies depending on the print resolution of the product.
    - 203 dpi : 1 dot = 0.125 mm (0.0049")
    - 305 dpi : 1 dot = 0.083 mm (0.0033")
    - 609 dpi : 1 dot = 0.042 mm (0.0017")
  - You can change the units to dots, " (inches), or mm in the [System] > [Regional] > [Unit] menu.
- 

### [Label Rotation]

Set the page orientation for label printing.

The label size set in the product is used as a reference for rotation.

The options are as follows:

#### 0 degree

Labels are printed in a portrait orientation.

#### 90 degree

Labels are printed in a landscape orientation.

#### 180 degree

Labels are printed in an inverse-portrait orientation.

#### 270 degree

Labels are printed in an inverse-landscape orientation.

### [Caret]

Set the caret (^) code.

The setting range is from 0 to 255.

---



- You need to set different values for each code (caret, delimiter, tilde).
- 

### [Delimiter]

Set the delimiter (,) code.

The setting range is from 0 to 255.



- You need to set different values for each code (caret, delimiter, tilde).
- 

### [Tilde]

Set the tilde (~) code.

The setting range is from 0 to 255.

---



- You need to set different values for each code (caret, delimiter, tilde).
- 

### [Clock Format]

Set the date format.

The options are as follows (January 24, 2017, at 1:45 pm, for example):

- [(none)]
- [MM/DD/YY (24-hour clock)] (Example: 01/24/17 (13:45))
- [MM/DD/YY (12-hour clock)] (Example: 01/24/17 (01:45))
- [DD/MM/YY (24-hour clock)] (Example: 24/01/17 (13:45))
- [DD/MM/YY (12-hour clock)] (Example: 24/01/17 (01:45))

### [Default Font]

Select a default font from the list for when printing using a multilingual font contained in the product.

### [SIPL]

To use SIPL as a printer command, set the following items:

### [Font Settings]

Set the font.

The setting items are as follows:

#### [Code Page]

Select the code page to be used from the list.

### [New Font Encoding]

Enable or disable new font encoding.

The options are as follows:

#### Enabled

Enable new font encoding.

#### Disabled

Disable new font encoding.





- Contact your SATO sales representative for more information about the new font.
- 

### [c20 Proportional Pitch]

Set whether to print each character using a proportional pitch or fixed pitch.

The options are as follows:

#### Enabled

Print each character with a proportional pitch.

#### Disabled

Print all characters with a fixed pitch.

### [Zero Slash]

Set whether to print the number zero (0) with or without a slash (/).

The options are as follows:

#### Enabled

Print zero with a slash.

#### Disabled

Print zero without a slash.

### [Format Save]

Set whether to save the user format data registered at printing in the product.

The options are as follows:

#### Enabled

Save the user format data registered at printing in the product.

#### Disabled

Do not save the user format data registered at printing in the product. The user format data remains in the product memory after printing until the product is powered off. You need to register a user format again after reboot.

### [SDPL]

To use SDPL as a printer command, set the following items:



- [Format Attribute], [Pause Mode], [1 Byte Codepage], [SDPL Measure Unit], [Scalable Font Style], [Feedback Character], [SOH Commands] and [Module Selection] are available only if [Settings] is selected for the corresponding setting item under the [Prioritize] menu.
- 

### [Control Code]

Set the control code.

The setting items are as follows:

#### [Code Type]

Set the type of the control code.

The options are as follows:

- [Standard]
- [Alternate 1]
- [Alternate 2]
- [Custom]

#### [SOH]

Set the SOH code.

You can change this if you have selected [Custom] in the [Code Type] menu.

The setting range is from 00 to ff (hexadecimal).

#### [STX]

Set the STX code.

You can change this if you have selected [Custom] in the [Code Type] menu.

The setting range is from 00 to ff (hexadecimal).

#### [CR]

Set the CR code.

You can change this if you have selected [Custom] in the [Code Type] menu.

The setting range is from 00 to ff (hexadecimal).

#### [CNTBY]

Set the CNTBY code.

You can change this if you have selected [Custom] in the [Code Type] menu.

The setting range is from 00 to ff (hexadecimal).

#### [Label Rotation]

Set the page orientation for label printing.

The label size set in the product is used as a reference for rotation.

The options are as follows:

##### 0 degree

Labels are printed in a portrait orientation.

##### 90 degree

Labels are printed in a landscape orientation.

##### 180 degree

Labels are printed in an inverse-portrait orientation.

## 270 degree

Labels are printed in an inverse-landscape orientation.

### [SOP Emulation]

Set the SOP emulation.

The options are as follows:

- [Disabled]
- [Prodigy Plus - 110]
- [Allegro - 220]
- [Prodigy - 250]
- [Auto]

### [Compatible Mode]

Set the compatible mode for SDPL.

The setting items are as follows:

#### [TTF]

Enable or disable TrueType font compatible mode.

The options are as follows:

##### Enabled

Enable TrueType font compatible mode. The bold TrueType fonts are printed in smaller pitch.

##### Disabled

Disable TrueType font compatible mode.

### [Graphics]

Set whether to allow the registration of graphic data even if a line feed code is omitted.

The options are as follows:

##### Enabled

Allow the registration of graphic data even when a line feed code is omitted.

##### Disabled

Do not allow the registration of graphic data when a line feed code is omitted.

### [Compression]

Set whether to accept graphic data created by a unique compression method.

The options are as follows:

##### Enabled

Accepts graphic data created by a unique compression method.

Disabled

Does not accept graphic data created by a unique compression method.

**[Right-to-Left print]**

Set the Right-to-Left printing function.

The options are as follows:

Disabled

All texts are printed from left to right.

Auto

When an Arabic font is detected, the Arabic text is printed from right to left.

**[Receive TimeOut]**

Set a period of time the product stays in binary data receiving mode.

When the specified period of time passes, the product exits from binary receiving mode and scans for SDPL commands.

The setting range is from 0 (off) to 9999 ms.

**[Blank Item Feed]**

Set whether to feed a label with nothing printed on it when the product receives label formatting commands that do not generate any printable image.

The options are as follows:

Enabled

Feeds a label with nothing printed on it.

Disabled

Does not feed a label with nothing printed on it.

**[Prioritize]**

Select the settings to be prioritized for each setting item of the SDPL command. You can set whether to prioritize settings that are done through the product or through commands.

When you select [Settings] for an item, the setting specified in the [SDPL] menu of the product will be used.

The setting items are as follows:

**[Format Attribute]**

Set whether to prioritize the settings that are done through the product or through commands for the format attribute setting.

The options are as follows:

Commands

Prioritize the settings through commands.

### Settings

Prioritize the settings that are done through the product.

### **[Pause Mode]**

Set whether to prioritize the settings that are done through the product or through commands for the pause mode setting.

The options are as follows:

#### Commands

Prioritize the settings through commands.

#### Settings

Prioritize the settings that are done through the product.

### **[1 Byte Codepage]**

Set whether to prioritize the settings that are done through the product or through commands for the 1 byte code page setting.

The options are as follows:

#### Commands

Prioritize the settings through commands.

#### Settings

Prioritize the settings that are done through the product.

### **[SDPL Measure Unit]**

Set whether to prioritize the settings that are done through the product or through commands for the measurement unit setting.

The options are as follows:

#### Commands

Prioritize the settings through commands.

#### Settings

Prioritize the settings that are done through the product.

### **[Scalable Font Style]**

Set whether to prioritize the settings that are done through the product or through commands for the scalable font style settings.

The options are as follows:

#### Commands

Prioritize the settings through commands.

#### Settings

Prioritize the settings that are done through the product.

### [Sensor Type]

Set whether to prioritize the settings that are done through the product or through commands for the sensor type setting.

The options are as follows:

#### Commands

Prioritize the settings through commands.

#### Settings

Prioritize the settings that are done through the product.

### [Feedback Character]

Set whether to prioritize the settings that are done through the product or through commands for the feedback character setting.

The options are as follows:

#### Commands

Prioritize the settings through commands.

#### Settings

Prioritize the settings that are done through the product.

### [SOH Commands]

Set whether to prioritize the settings that are done through the product or through commands for the SOH Commands settings.

The options are as follows:

#### Commands

Prioritize the settings through commands.

#### Settings

Prioritize the settings that are done through the product.

### [Module Selection]

Set whether to prioritize the settings that are done through the product or through commands for the module selection setting.

The options are as follows:

#### Commands

Prioritize the settings through commands.

#### Settings

Prioritize the settings that are done through the product.



- Even if you select [Commands], the settings that are done through the product are used if no command is sent.
- 

## Others

The option selected in the [Printing] > [Advanced] > [Prioritize] menu is applied to the following settings and shown on the screen.

- [Darkness]
- [Factory Offset]
- [Speed]

## [Format Attribute]

Set the format attribute.

You can change this setting if you have selected [Settings] in the [Prioritize] > [Format Attribute] menu.

The options are as follows:

- [XOR]
- [Transparent]
- [Opaque]
- [Inverse]

## [Pause Mode]

Enable or disable the pause mode.

You can change this setting if you have selected [Settings] in the [Prioritize] > [Pause Mode] menu.

The options are as follows:

### Enabled

Enable the pause mode.

### Disabled

Disable the pause mode.

## [1 Byte Codepage]

Select the code page to be used for one-byte characters from the list.

You can change this setting if you have selected [Settings] in the [Prioritize] > [1 Byte Codepage] menu.

## [SDPL Measure Unit]

Set the measurement unit.

You can change this setting if you have selected [Settings] in the [Prioritize] > [SDPL Measure Unit] menu.

The options are as follows:

- [Inch]
- [Millimeter]

### [Scalable Font Style]

Set the style of the scalable fonts.

You can change this setting if you have selected [Settings] in the [Prioritize] > [Scalable Font Style] menu.

The setting items are as follows:

#### [Bold]

Set whether to use bold for the scalable fonts.

The options are as follows:

##### Enabled

Use bold.

##### Disabled

Do not use bold.

#### [Italic]

Set whether to use italics for the scalable fonts.

The options are as follows:

##### Enabled

Use italics.

##### Disabled

Do not use italics.

### [Feedback Character]

Enable or disable the <STX>a command.

You can change this setting if you have selected [Settings] in the [Prioritize] > [Feedback Character] menu.

The options are as follows:

##### Enabled

Enable the <STX>a command.

##### Disabled

Disable the <STX>a command.

### [SOH Commands]

Set the SOH commands.

You can change this setting if you have selected [Settings] in the [Prioritize] > [SOH Commands] menu.

The setting items are as follows:



### [All Commands]

Enable or disable all the SOH commands. You can also select to set each command individually.

The options are as follows:

#### Disabled

Disable all the SOH commands.

#### Enabled

Enable all the SOH commands.

#### Custom

Enable or disable each type of the SOH commands individually.

### [SOH-B Command]

Enable or disable the SOH-B command.

Available if you have selected [Custom] in the [All Commands] menu.

The options are as follows:

#### Enabled

Enable the SOH-B command.

#### Disabled

Disable the SOH-B command.

### [SOH-C Command]

Enable or disable the SOH-C command.

Available if you have selected [Custom] in the [All Commands] menu.

The options are as follows:

#### Enabled

Enable the SOH-C command.

#### Disabled

Disable the SOH-C command.

### [Others]

Enable or disable the SOH commands other than the SOH-B and SOH-C commands.

Available if you have selected [Custom] in the [All Commands] menu.

The options are as follows:

#### Enabled

Enable the SOH commands other than the SOH-B and SOH-C commands.

#### Disabled

Disable the SOH commands other than the SOH-B and SOH-C commands.

### [Module Selection]

Select where to save the product settings.

You can change this setting if you have selected [Settings] in the [Prioritize] > [Module Selection] menu.

You can select from A, B, C (Assigned by <STX> X), D, F, G, H, I, J, X, Y, and Z.

### [AEP]

Set the functions for AEP (Application Enabled Printing).

AEP mode allows you to use the product as a stand-alone printer by running applications within the product.

Use the standard application, or install custom applications to the product from a USB memory, All-In-One Tool, WebConfig page, etc.

In AEP mode, you can use USB keyboards and barcode scanners to input data.

The setting items are as follows:



- Contact your SATO sales representative for more information about the use of AEP mode.
- 

### [Enable]

Enable or disable AEP (Application Enabled Printing) mode.

The options are as follows:

#### Enabled

Enable AEP mode.

#### Disabled

Disable AEP mode.



- A message prompting you to restart the product will appear on the Online/Offline screen if you have made any changes. In such a case, reboot the product to apply the settings.
- 

### [Starting Application]

Select the application to start at product startup in AEP (Application Enabled Printing) mode.

Select the application using the  /  buttons and press the  button to confirm.



- The simple standalone application is preloaded as the initial setting of the starting application in AEP mode.
- 

### [Delete Application]

Delete installed applications from the list.

Select the application to be deleted using the  /  buttons and press the  button to confirm.

### [Label Rotation]

Set whether to rotate the page orientation for label printing.

The options are as follows:

#### Enabled

Rotates the page orientation 180 degrees.

#### Disabled

Does not rotate the page orientation.

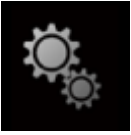

## [System] Menu

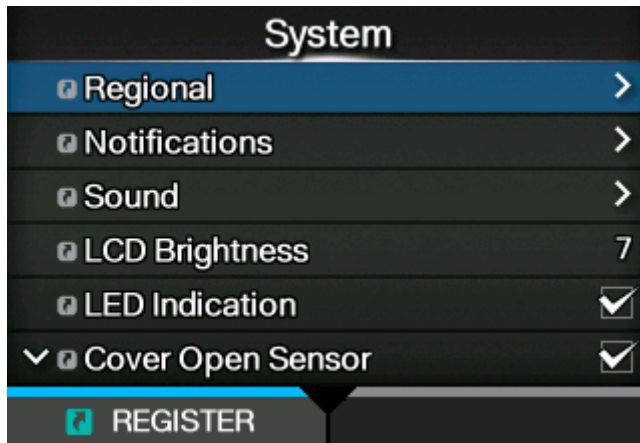

The following settings are available in the [System] menu:

### [Regional]

Set the display language, time zone, calendar and unit.

The setting items are as follows:

### [Messages]

Set the display language.

Select the display language from the list.

### [USB Keyboard]

Set the language for the USB keyboard connected to the product.

Select the USB keyboard layout from Western and Eastern European languages, Japanese, Chinese and Korean.



- Japanese, Chinese, and Korean only support a change in the layout of the keyboard. The IME (Input Method Editor) is not compatible, so you cannot input hiragana, katakana, or kanji.

### [Locale]

Set the locale to be used in AEP (Application Enabled Printing) mode.

This setting determines the format of time, dates, numbers, prices, names of weekdays, months, etc. in AEP applications.

Select the locale from the list.

## [Unit]

Set the unit of length for indication.

The options are as follows:



- [dot]
- ["'] (inches)
- [mm]

## [Time]

Set the time.

You can set the time only if you have selected [Disabled] in the [Interface] > [Network] > [Services] > [NTP] > [Enable] menu.

After setting the time and pressing the  button, the confirmation screen appears.

Press the  button to cancel, or press the  button to confirm the setting.

## [Date]

Set the date.

You can set the date only if you have selected [Disabled] in the [Interface] > [Network] > [Services] > [NTP] > [Enable] menu.



The setting range is as follows:

2000-01-01 to 2035-12-31



- The date format is Year - Month - Date.
- 

After setting the date and pressing the  button, the confirmation screen appears.

Press the  button to cancel, or press the  button to confirm the setting.

## [Time Zone]

Set the time zone.

First select the region from the [Region] list.

Then select the city from the [City] list.

## [Display Language Icon]

Set whether to display the [Language] icon on the top screen of the [Settings] menu.

The options are as follows:

### Enabled

Display the [Language] icon.

### Disabled

Do not display the [Language] icon.

If this function is enabled, the [Language] icon is added to the [Settings] menu screen as below. You can directly access the display language setting screen.

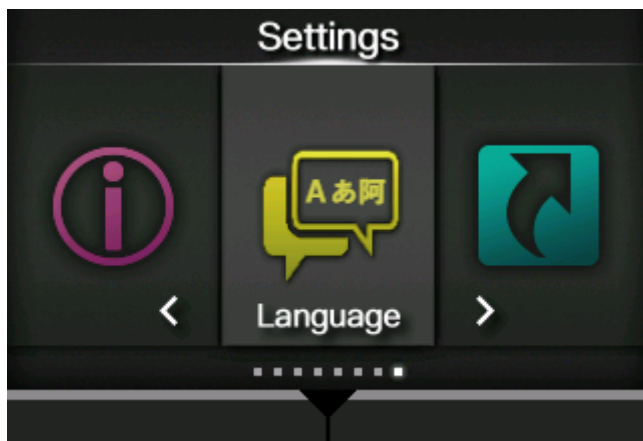

### [Notifications]

Set the function to notify when to clean and replace parts.

The setting items are as follows:

#### [Clean Printhead]

Notify when the print head needs to be cleaned.

The setting items are as follows:

#### [Clean Printhead]

Enable or disable the notification function about when the print head needs to be cleaned.

The options are as follows:

##### Enabled

Enable the notification function.

##### Disabled

Disable the notification function.

#### [Cleaning Interval]

Set the notification interval about when the print head needs to be cleaned.

You can change this setting if you have selected [Enabled] in the [Clean Printhead] menu.

The product shows the print distance as a set value. The setting range is from 10 to 1000 meters.

#### [Clean Counter]

Shows the current print distance.

#### [Change Printhead]

Notify when the print head needs to be replaced.

The setting items are as follows:

### **[Change Printhead]**

Enable or disable the notification function about when the print head needs to be replaced.

The options are as follows:

#### Enabled

Enable the notification function.

#### Disabled

Disable the notification function.

### **[Printhead Interval]**

Set the notification interval about when the print head needs to be replaced.

You can change this setting if you have selected [Enabled] in the [Change Printhead] menu.

The product shows the print distance as a set value. The setting range is from 10 to 100 km.

### **[Printhead Count]**

Shows the current print distance.

### **[Change Platen]**

Notify when the platen roller needs to be replaced.

The setting items are as follows:

### **[Change Platen]**

Enable or disable the notification function about when the platen roller needs to be replaced.

The options are as follows:

#### Enabled

Enable the notification function.

#### Disabled

Disable the notification function.

### **[Platen Interval]**

Set the notification interval about when the platen roller needs to be replaced.

You can change this setting if you have selected [Enabled] in the [Change Platen] menu.

The product shows the fed distance as a set value. The setting range is from 10 to 100 km.

### **[Platen Count]**

Shows the current distance the platen roller has fed.

### **[Change Belt(Gear Box)]**

Notify when the gearbox timing belt needs to be replaced.

The setting items are as follows:

### [Change Belt]

Enable or disable the notification function about when the gearbox timing belt needs to be replaced.

The options are as follows:

#### Enabled

Enable the notification function.

#### Disabled

Disable the notification function.

### [Belt Interval]

Set the notification interval about when the gearbox timing belt needs to be replaced.

You can change this setting if you have selected [Enabled] in the [Change Belt] menu.

The product shows the print distance as a set value. The setting range is from 10 to 300 km.

### [Belt Count]

Shows the current distance the belt has advanced the media in the eject direction.

### [Change Belt(Ribbon)]

Notify when the ribbon timing belt needs to be replaced.

The setting items are as follows:

### [Change Belt]

Enable or disable the notification function about when the ribbon timing belt needs to be replaced.

The options are as follows:

#### Enabled

Enable the notification function.

#### Disabled

Disable the notification function.

### [Belt Interval]

Set the notification interval about when the ribbon timing belt needs to be replaced.

You can change this setting if you have selected [Enabled] in the [Change Belt] menu.

The product shows the print distance as a set value. The setting range is from 10 to 300 km.

### [Belt Count]

Shows the current distance the belt has advanced the media in the eject direction.

### [Sound]

Set the buzzer sound.

The setting item is as follows:



### [Error Sound]

Set the buzzer volume for the error sound.

The options are as follows:

#### Off

Mute the sound.

#### Low

Low volume.

#### Medium

Medium volume.

#### High

High volume.

### [LCD Brightness]

Set the brightness of the screen.

The setting range is from 0 to 9.

0 is the darkest and 9 is the brightest.



- The product has a built-in energy saving function, which will decrease the brightness of the screen when you have not operated the product for a period.
- 

### [LED Indication]

Enable or disable the LED indicator to show the current status of the product.

The options are as follows:

#### Enabled

The LED indicator lights up, flashes, or turns off according to the product status.

#### Disabled

The LED indicator is always off.

### [Cover Open Sensor]

Enable or disable cover open switch.

The options are as follows:

#### Enabled

Enables the cover open switch.

A cover open error (error 1029) occurs when the top cover is opened.

### Disabled

Disables the cover open switch.

A cover open error (error 1029) does not occur even if the top cover is opened.



- If this setting is disabled, the product operates even while the top cover is open. Be careful that nothing, such as your hands or hair, becomes trapped in the rollers.
- Dust may get into the product if it is used while the top cover is open, which could lead to bad print quality.



- You can disable this setting so the cover open error is disabled and you can work with the top cover open while doing maintenance or to temporarily print when the cover open switch has malfunctioned. However, if the cover open switch malfunctions, immediately contact your SATO technical support to request replacement parts.
- 

## [Show Total Count]

Enable or disable the indication of the total print count.

If set to [Enabled], the total print count appears on both the Online and Offline screens.

The number in the brackets to the right of [QTY] on the Online and Offline screens is the total print count.

The options are as follows:

### Enabled

Enable the indication of the total print count.

### Disabled

Disable the indication of the total print count.



- Shows the total print count from the time the product is on until it is off. When you power off the product, the count is reset to [0].
- 

## [Password]

Set the password.

The setting items are as follows:

### [Password Enable]

Enable or disable the password setting.

If you have set the password to [Enabled], the product requires you to enter the password set in the [Password] screen before you enter the [Settings] menu.

The options are as follows:

#### Enabled

Enable the password setting.

#### Disabled

Disable the password setting.



- The default password is "USB serial number (8 digits of uppercase English letters and numerals) +user". You can confirm the USB serial number in the following ways.
  - [USB Serial] item on [Device] on the [Dashboard] page of the web configuration page
  - [Information] > [USB Serial] menu
  - Test print results executed by [Tools] > [Test Print] > [Configure List] menu

You can change the password in [Password] > [Change Password] > [level1].

---

### [Install Security]

Enable or disable the password input for installing the pkg file to the product.

If you have enabled the password input, the product requires you to enter the password set in the [Password] screen before you can download the package file.

The options are as follows:

#### Disabled

No password is required to install a pkg file.

#### USB

Password is required to install a pkg file from the USB memory.

#### Always

Password is required to install a pkg file from the USB memory or downloaded from computer.



- The password used for installing a pkg file can be any passwords set in the [System] > [Password].

Contact your SATO reseller or technical support for more information of the pkg file.

---

### [NFC Security]

Set whether to show the confirmation message or enable the password input before settings are written to the product from an Android device with the NFC interface.

To use the NFC Security function, the settings must be written from the Android device while the product is powered off. The confirmation message or password input screen is shown when the product is powered on.

The options are as follows:

#### None

No confirmation message is shown and no password is required before the settings are written to the product.

### Confirm

The confirmation message is shown before the settings are written to the product.

### Password

You need to enter the password set in the [Password] screen before the settings are written to the product.

## [Change Password]

Change the password.

You can enter 4 to 32 characters. Alphabets (capital and small letters), numbers and symbols can be used.

The setting items are as follows:

### admin

This is the setting item for factory.

Strictly for SATO authorized personnel use.

### manager

The password for accessing the [Service] menu.

Strictly for SATO authorized personnel use.

### level1

The password for accessing the [Settings] menu.



- Passwords other than [level1] are exclusively for factory and maintenance personnel.
-



## [Tools] Menu



The following settings are available in the [Tools] menu:



### [Test Print]

Perform a test print.

The setting items are as follows:

### [Factory]

Perform the factory test print.

1. Check and set the items as listed on the [Factory] menu.
2. Press the  button to start the test print. Press the  button again to pause the print.

To stop the test print, first pause the print and then press the  button.

The setting items are as follows:

#### Label Width

Set the media width used for the test print.

The options are [Large] (101.6 mm (4")) and [Small] (50.8 mm (2")).

#### Pitch

Set the print position in the vertical direction.

The setting range varies depending on the print resolution of the product.

The setting range is as follows:

Resolution	S84NX	S86NX
203 dpi (1 dot = 0.125 mm (0.0049"))	-30 to 0 to 30 dots	-30 to 0 to 30 dots
305 dpi (1 dot = 0.083 mm (0.0033"))	-45 to 0 to 45 dots	-45 to 0 to 45 dots
609 dpi (1 dot = 0.042 mm (0.0017"))	-90 to 0 to 90 dots	-

When you decrease the setting value, the print position moves in the feed direction (toward the front part of the media).

When you increase the setting value, the print position moves opposite the feed direction (toward the end part of the media).

#### Offset

Set the stop position of the media.

The setting range varies depending on the print resolution of the product.

The setting range is as follows:

Resolution	S84NX	S86NX
203 dpi (1 dot = 0.125 mm (0.0049"))	-30 to 0 to 30 dots	-30 to 0 to 30 dots
305 dpi (1 dot = 0.083 mm (0.0033"))	-45 to 0 to 45 dots	-45 to 0 to 45 dots
609 dpi (1 dot = 0.042 mm (0.0017"))	-90 to 0 to 90 dots	-

When you decrease the setting value, the stop position moves in the feed direction (toward the front part of the media).

When you increase the setting value, the stop position moves opposite the feed direction (toward the end part of the media).

#### Darkness Adjust

Fine tune the print darkness of the test print.

The setting range is from 0 to 99.



0 is the lightest and 99 is the darkest.



- You can change the units to dots, " (inches), or mm in the [System] > [Regional] > [Unit] menu.
- The value of [Pitch], [Offset] and [Darkness Adjust] set in the [Factory] menu will be reflected to the same item settings in the [Configure List] menu, [Configure QR] menu, [Paper Sensor] menu and [Head Check] menu.
- The settings in [Pitch], [Offset], and [Darkness Adjust] are linked and are changed with the settings in the [Printing] > [Advanced] > [Adjustments] menu.

## [Configure List]

Print the product's settings information.

1. Check and set the items as listed on the [Configure List] menu.
2. Press the  button to start the test print. Press the  button again to pause the print.

To stop the test print, first pause the print and then press the  button.

The setting items are as follows:

### Label Width

Shows the necessary media width of the test print.

The necessary media width is 50.8 mm (2") for [Small].

### Label Length

Set the length of one piece of the media used for the test print.

The setting range varies depending on the print resolution of the product.

The setting range is as follows:

Resolution	S84NX	S86NX
203 dpi (1 dot = 0.125 mm (0.0049"))	400 to 1600 dots	400 to 1600 dots
305 dpi (1 dot = 0.083 mm (0.0033"))	600 to 2400 dots	600 to 2400 dots
609 dpi (1 dot = 0.042 mm (0.0017"))	1200 to 4800 dots	-

### Pitch

Set the print position in the vertical direction.

The setting range varies depending on the print resolution of the product.

The setting range is as follows:

Resolution	S84NX	S86NX
203 dpi (1 dot = 0.125 mm (0.0049"))	-30 to 0 to 30 dots	-30 to 0 to 30 dots
305 dpi (1 dot = 0.083 mm (0.0033"))	-45 to 0 to 45 dots	-45 to 0 to 45 dots
609 dpi (1 dot = 0.042 mm (0.0017"))	-90 to 0 to 90 dots	-

When you decrease the setting value, the print position moves in the feed direction (toward the front part of the media).

When you increase the setting value, the print position moves opposite the feed direction (toward the end part of the media).

#### Offset

Set the stop position of the media.

The setting range varies depending on the print resolution of the product.

The setting range is as follows:

Resolution	S84NX	S86NX
203 dpi (1 dot = 0.125 mm (0.0049"))	-30 to 0 to 30 dots	-30 to 0 to 30 dots
305 dpi (1 dot = 0.083 mm (0.0033"))	-45 to 0 to 45 dots	-45 to 0 to 45 dots
609 dpi (1 dot = 0.042 mm (0.0017"))	-90 to 0 to 90 dots	-

When you decrease the setting value, the stop position moves in the feed direction (toward the front part of the media).

When you increase the setting value, the stop position moves opposite the feed direction (toward the end part of the media).

#### Darkness Adjust

Fine tune the print darkness of the test print.

The setting range is from 0 to 99.

0 is the lightest and 99 is the darkest.







- You can change the units to dots, " (inches), or mm in the [System] > [Regional] > [Unit] menu.
- The changes to the settings in this menu are linked and are changed with each of the test print settings under the [Test Print] menu.
- The settings in [Pitch], [Offset], and [Darkness Adjust] are linked and are changed with the settings in the [Printing] > [Advanced] > [Adjustments] menu.

## [Configure QR]

Print the product's settings information as a QR code.

1. Check and set the items as listed on the [Configure QR] menu.
2. Press the  button to start the test print. Press the  button again to pause the print.

To stop the test print, first pause the print and then press the  button.

The setting items are as follows:

### Label Width

Shows the necessary media width of the test print.

The necessary media width is 50.8 mm (2") for [Small].

### Label Length

Set the length of one piece of the media used for the test print.

The setting range varies depending on the print resolution of the product.

The setting range is as follows:

Resolution	S84NX	S86NX
203 dpi (1 dot = 0.125 mm (0.0049"))	400 to 1600 dots	400 to 1600 dots
305 dpi (1 dot = 0.083 mm (0.0033"))	600 to 2400 dots	600 to 2400 dots
609 dpi (1 dot = 0.042 mm (0.0017"))	1200 to 4800 dots	-

### Pitch

Set the print position in the vertical direction.

The setting range varies depending on the print resolution of the product.

The setting range is as follows:

Resolution	S84NX	S86NX
203 dpi (1 dot = 0.125 mm (0.0049"))	-30 to 0 to 30 dots	-30 to 0 to 30 dots
305 dpi (1 dot = 0.083 mm (0.0033"))	-45 to 0 to 45 dots	-45 to 0 to 45 dots
609 dpi (1 dot = 0.042 mm (0.0017"))	-90 to 0 to 90 dots	-

When you decrease the setting value, the print position moves in the feed direction (toward the front part of the media).

When you increase the setting value, the print position moves opposite the feed direction (toward the end part of the media).

#### Offset

Set the stop position of the media.

The setting range varies depending on the print resolution of the product.

The setting range is as follows:

Resolution	S84NX	S86NX
203 dpi (1 dot = 0.125 mm (0.0049"))	-30 to 0 to 30 dots	-30 to 0 to 30 dots
305 dpi (1 dot = 0.083 mm (0.0033"))	-45 to 0 to 45 dots	-45 to 0 to 45 dots
609 dpi (1 dot = 0.042 mm (0.0017"))	-90 to 0 to 90 dots	-

When you decrease the setting value, the stop position moves in the feed direction (toward the front part of the media).

When you increase the setting value, the stop position moves opposite the feed direction (toward the end part of the media).

#### Darkness Adjust

Fine tune the print darkness of the test print.

The setting range is from 0 to 99.



0 is the lightest and 99 is the darkest.



- You can change the units to dots, " (inches), or mm in the [System] > [Regional] > [Unit] menu.
- The changes to the settings in this menu are linked and are changed with each of the test print settings under the [Test Print] menu.
- The settings in [Pitch], [Offset], and [Darkness Adjust] are linked and are changed with the settings in the [Printing] > [Advanced] > [Adjustments] menu.

## [Paper Sensor]

Print the detection result of the media sensor level.

1. Check and set the items as listed on the [Paper Sensor] menu.
2. Press the  button to start the test print. Press the  button again to pause the print.

To stop the test print, first pause the print and then press the  button.

The setting items are as follows:

### Label Width

Shows the necessary media width of the test print.

The necessary media width is 50.8 mm (2") for [Small].

### Label Length

Set the length of one piece of the media used for the test print.

The setting range varies depending on the print resolution of the product.

The setting range is as follows:

Resolution	S84NX	S86NX
203 dpi (1 dot = 0.125 mm (0.0049"))	400 to 1600 dots	400 to 1600 dots
305 dpi (1 dot = 0.083 mm (0.0033"))	600 to 2400 dots	600 to 2400 dots
609 dpi (1 dot = 0.042 mm (0.0017"))	1200 to 4800 dots	-

### Pitch

Set the print position in the vertical direction.

The setting range varies depending on the print resolution of the product.

The setting range is as follows:

Resolution	S84NX	S86NX
203 dpi (1 dot = 0.125 mm (0.0049"))	-30 to 0 to 30 dots	-30 to 0 to 30 dots
305 dpi (1 dot = 0.083 mm (0.0033"))	-45 to 0 to 45 dots	-45 to 0 to 45 dots
609 dpi (1 dot = 0.042 mm (0.0017"))	-90 to 0 to 90 dots	-

When you decrease the setting value, the print position moves in the feed direction (toward the front part of the media).

When you increase the setting value, the print position moves opposite the feed direction (toward the end part of the media).

#### Offset

Set the stop position of the media.

The setting range varies depending on the print resolution of the product.

The setting range is as follows:

Resolution	S84NX	S86NX
203 dpi (1 dot = 0.125 mm (0.0049"))	-30 to 0 to 30 dots	-30 to 0 to 30 dots
305 dpi (1 dot = 0.083 mm (0.0033"))	-45 to 0 to 45 dots	-45 to 0 to 45 dots
609 dpi (1 dot = 0.042 mm (0.0017"))	-90 to 0 to 90 dots	-

When you decrease the setting value, the stop position moves in the feed direction (toward the front part of the media).

When you increase the setting value, the stop position moves opposite the feed direction (toward the end part of the media).

#### Darkness Adjust

Fine tune the print darkness of the test print.

The setting range is from 0 to 99.



0 is the lightest and 99 is the darkest.



- You can change the units to dots, " (inches), or mm in the [System] > [Regional] > [Unit] menu.
- The changes to the settings in this menu are linked and are changed with each of the test print settings under the [Test Print] menu.
- The settings in [Pitch], [Offset], and [Darkness Adjust] are linked and are changed with the settings in the [Printing] > [Advanced] > [Adjustments] menu.

## [Head Check]

Perform the head check print.

1. Check and set the items as listed on the [Head Check] menu.
2. Press the  button to start the head check print. Press the  button again to pause the print.

To stop the head check print, first pause the print and then press the  button.

The setting items are as follows:

### Label Width

Set the media width used for the head check print.

The setting range varies depending on the print resolution of the product.

The setting range is as follows:

Resolution	S84NX	S86NX
203 dpi (1 dot = 0.125 mm (0.0049"))	320 to 832 dots	320 to 1340 dots
305 dpi (1 dot = 0.083 mm (0.0033"))	480 to 1248 dots	480 to 2010 dots
609 dpi (1 dot = 0.042 mm (0.0017"))	960 to 2496 dots	-

### Label Length

Set the length of one piece of the media used for the head check print.

The setting range varies depending on the print resolution of the product.

The setting range is as follows:

Resolution	S84NX	S86NX
203 dpi	40 to 240 dots	40 to 240 dots

Resolution	S84NX	S86NX
(1 dot = 0.125 mm (0.0049"))		
305 dpi (1 dot = 0.083 mm (0.0033"))	60 to 360 dots	60 to 360 dots
609 dpi (1 dot = 0.042 mm (0.0017"))	120 to 720 dots	-

### Pitch

Set the print position in the vertical direction.

The setting range varies depending on the print resolution of the product.

The setting range is as follows:

Resolution	S84NX	S86NX
203 dpi (1 dot = 0.125 mm (0.0049"))	-30 to 0 to 30 dots	-30 to 0 to 30 dots
305 dpi (1 dot = 0.083 mm (0.0033"))	-45 to 0 to 45 dots	-45 to 0 to 45 dots
609 dpi (1 dot = 0.042 mm (0.0017"))	-90 to 0 to 90 dots	-

When you decrease the setting value, the print position moves in the feed direction (toward the front part of the media).

When you increase the setting value, the print position moves opposite the feed direction (toward the end part of the media).

### Offset

Set the stop position of the media.

The setting range varies depending on the print resolution of the product.

The setting range is as follows:

Resolution	S84NX	S86NX
203 dpi (1 dot = 0.125 mm (0.0049"))	-30 to 0 to 30 dots	-30 to 0 to 30 dots
305 dpi	-45 to 0 to 45 dots	-45 to 0 to 45 dots

Resolution	S84NX	S86NX
(1 dot = 0.083 mm (0.0033"))		
609 dpi (1 dot = 0.042 mm (0.0017"))	-90 to 0 to 90 dots	-

When you decrease the setting value, the stop position moves in the feed direction (toward the front part of the media).

When you increase the setting value, the stop position moves opposite the feed direction (toward the end part of the media).

#### Darkness Adjust

Fine tune the print darkness of the head check print.

The setting range is from 0 to 99.

0 is the lightest and 99 is the darkest.



- You can change the units to dots, " (inches), or mm in the [System] > [Regional] > [Unit] menu.
  - The changes to the settings in this menu are linked and are changed with each of the test print settings under the [Test Print] menu.
  - The settings in [Pitch], [Offset], and [Darkness Adjust] are linked and are changed with the settings in the [Printing] > [Advanced] > [Adjustments] menu.
- 

## [HEX-Dump]

Save the hex dump print data or dump data from the receive buffer to the USB memory.

The setting items are as follows:

### [Hex Dump Mode]

Enable or disable the Hex Dump mode.

If you set [Hex Dump Mode] to [Enabled], the product prints the received data and at the same time creates a file of the received data inside "hexdump/".

When you return the setting to [Disabled], you can check the file on the screen.



- If you set [Hex Dump Mode] to [Enabled], the icon on the Online/Offline screen changes.



- You can save a maximum of 10 received data files for each type of interface. Depending on the file size, the number of files you can save will be less than 10.
- The details of the files created in "hexdump/" in the product are as follows:

#### **LAN00xx.bin**

Received data through LAN.

#### **NFC00xx.bin**

Received data through NFC.

#### **PIPE00xx.bin**

Received data through pipe.

#### **SCI00xx.bin**

Received data through RS-232C.

#### **USB00xx.bin**

Received data through USB.



### **WIFI00xx.bin**

Received data through wireless LAN.

- You can print or delete the files created inside "hexdump/" of the product from [Log Files] menu.
- 

### **[Buffer Dump]**

Save the receive buffer data to the product.

Available if you have set to [Disabled] in the [Hex Dump Mode] menu.

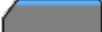
Press the [START] button (  button) on the startup screen to save the data to the product.

Save the receive buffer data to "buff/" in the product.

---



- The data files of the receive buffer are created for each type of interface.
- The details of the files created in "buff/" in the product are as follows:

#### **LAN0001.bin**

The contents of the receive buffer for LAN.

#### **NFC0001.bin**

The contents of the receive buffer for NFC.

#### **PIPE0001.bin**

The contents of the receive buffer for pipe.

#### **SCI0001.bin**

The contents of the receive buffer for RS-232C.

#### **USB0001.bin**

The contents of the receive buffer for USB.

#### **WIFI0001.bin**

The contents of the receive buffer for wireless LAN.

- If you perform the [Buffer Dump] again, the existing file will be overwritten.
  - You can print or delete files from the [Log Files] menu.
- 

### **[Log Files]**

Manage the log files of the product.

The setting items are as follows:

#### **[Copy]**



Copy the log files of the product to the USB memory.

Available only if you have installed the USB memory.



- Be sure to perform a virus check on the USB memory before connecting it to the product. SATO Corporation shall not be held responsible for any product malfunctions caused by a virus spread via USB memory.
- 

The procedure to copy the log files is as follows:

1. Select the file type to copy and press the  button.
  - **buff/**  
The buffer data saved when you perform the [Buffer Dump].
  - **hexdump/**  
The received data created through [Hex Dump Mode].
2. Select the file to copy and press the  button. A check mark appears on the right side of the file name.
3. After you select the file, press the  button to copy the selected file to the USB memory.





- When [Hex Dump Mode] is set to [Enabled], it may take some time before the files appear.
- 

### [Remove]

Delete the log files of the product.

The procedure to delete the log files is as follows:

1. Select the file type to delete and press the  button.
  - **buff/**  
The buffer data saved when you perform the [Buffer Dump].
  - **hexdump/**  
The received data created through [Hex Dump Mode].
2. Select the file to delete and press the  button. A check mark appears on the right side of the file name.
3. After you select the file, press the  button to delete the selected file.





- When [Hex Dump Mode] is set to [Enabled], it may take some time before the files appear.
- 

### [Print]

Print a hex dump of the log files of the product.

The procedure to print the log files is as follows:

1. Select the file type to print and press the  button.
  - **buff/**  
The buffer data saved when you perform the [Buffer Dump].
  - **hexdump/**  
The received data created through [Hex Dump Mode].
2. Select the file to print and press the  button or  button to perform the dump print.



- Printing the contents of the file may use a lot of media.



- When [Hex Dump Mode] is set to [Enabled], it may take some time before the files appear.
- 

## [Reset]

Initialize the setting values and data saved on the product.

Press  button to show the [Select] menu.

## [Select]

Select the items to be initialized.

The items are as follows:

## [Data]

Initialize the data saved on the product.

The data to be initialized are the fonts and graphics registered in the product.

When you select [Data], the confirmation screen appears.

Press the  button to cancel or  button to perform the initialization.

The product will reboot after the initialization.



- Normally, it is not necessary to perform the initialization. Doing so could change the print conditions.
- 

## [Data & Settings]

Initialize the data and setting values on the product.

Select the setting items to be initialized.

The options are as follows:

### User Reset

Initialize the data and setting values.

### User Reset (-Interface)

Initialize the data and setting values that are not included in the [Interface] menu.

Factory Reset

Initialize to the status after factory shipment.

Factory Reset (-Interface)

Initialize the items that are not included in the [Interface] menu to the status after factory shipment.

Interface

Initialize the data and setting values in the [Interface] menu.

Printing

Initialize the data and setting values in the [Printing] menu.

Select the item to be initialized using the  /  buttons and then press the  button to show the confirmation screen.

Press the  button to cancel or  button to perform the initialization.

The product will reboot after the initialization.



- The data to be initialized are the fonts and graphics registered in the product.
- 

**[Settings]**

Select the setting items to be initialized.

The options are as follows:

User Reset

Initialize the setting values.

User Reset (-Interface)

Initialize the setting values that are not included in the [Interface] menu.

Factory Reset

Initialize to the status after factory shipment.

Factory Reset (-Interface)

Initialize the items that are not included in the [Interface] menu to the status after factory shipment.

Interface

Initialize the setting values in the [Interface] menu.

Printing

Initialize the setting values in the [Printing] menu.

Select the item to be initialized using the  /  buttons and then press the  button to show the confirmation screen.

Press the  button to cancel or  button to perform the initialization.

After initialization, if a message prompting you to restart the product appears on the Online/Offline screen, reboot the product to apply the settings.

## [Profiles]

Maintain the customized profile of the product settings.

The name of the last loaded profile appears in the parentheses.





The setting items are as follows:

## [Delete]

Delete the profile of the product.

Not available if no profile is registered.

The procedure to delete the profile is as follows:





1. Select the profile to be deleted using the  /  buttons.
2. Press the  button or press the  button to confirm.  
The profile name is deleted from the list.

## [Load]

Load the profile of the product.

Not available if no profile is registered.

The procedure to load the profile is as follows:

1. Select the profile to be loaded using the  /  buttons.
2. Press the  button or press the  button to confirm.

A check mark appears on the right side of the loaded profile name. And the name of the loaded profile appears on the [Profiles] menu in the parentheses.

## [Save]

Save the current product settings as a new profile.

The screen shows a list of the profiles saved in the product. If no profile is saved, the screen shows an empty list.

## [Save as]

To save the current product settings as a new profile, press the  button and enter the name of the profile.

You can enter a maximum of 32 characters. You can use alphabets (capital and small letters), numbers and symbols.

Press the  button to confirm.

The new profile name appears on the list and is loaded.

**[Start with]**

Select the profile to be loaded at product startup.

Not available if no profile is registered.

The procedure to load the profile at product startup is as follows:

1. Select the profile to be loaded at product startup using the  /  buttons.
2. Press the  button or the  button to confirm.

**[Service]**

These are the setting items for service.

Strictly for SATO authorized service personnel use.

**[Factory]**

These are the setting items for factory.

Strictly for SATO authorized service personnel use.

**[Certificates]**

Install certificates used for Wi-Fi authentication and for HTTPS.

Available only if you have installed the USB memory.



- Be sure to perform a virus check on the USB memory before connecting it to the product. SATO Corporation shall not be held responsible for any product malfunctions caused by a virus spread via USB memory.
- 

The setting items are as follows:

**HTTPS**

Installs the HTTPS certificates from the USB memory.

**Wi-Fi Root CA**

Installs the Wi-Fi Root CA certificates from the USB memory.

**Wi-Fi Client**

Installs the Wi-Fi client certificates from the USB memory.

**Wi-Fi Private Key**

Installs the Wi-Fi private key from the USB memory.

**EAP-FAST PAC File**

Installs the EAP-FAST PAC file from the USB memory.

The procedure to install the certificates and PAC files is as follows:

1. Save the certificate files to the USB thumb drive memory's root folder.  
Acceptable file extensions are as follows:
  - .pem, .crt, .cer, .der for Root CA and client certificate in PEM or DER format
  - .pfx and .p12 for client certificates in PKCS #12 format
  - .prv and .key for private keys in PEM/PKCS#8 format
  - .pac for PAC files
2. Insert the USB memory into the USB connector (Type A).
3. Go to the [Settings] > [Tools] > [Certificates] menu.
4. Select the certificate you want to install. Refer to the item description above.
5. Select the certificate file from the list.

## [Barcode Checker]

Set the barcode check function.

By connecting a barcode checker to the product, you can check the barcodes after printing.



- This function is available only when the print mode is set to continuous mode.
  - You cannot use this function with the S84NX RFID models.
  - You cannot use this function in AEP mode.
- 

The setting items are as follows:

## [Test]

Set up the barcode checker.

The setting items are as follows:

### [Reader Name]

Shows the barcode checker connected to the product.

### [Reading Test]

Perform a test read with the connected barcode checker.

Available only if you have connected the barcode checker.

Set a label with barcodes within the scanning range of the barcode checker, and then press the



button to start reading.

If reading is successful, the code type and read data are displayed. The data is displayed only up to 23 bytes from the beginning.

If reading is unsuccessful, or the displayed results of the read are not correct, adjust the position of the barcode checker. For details on how to use the barcode checker, refer to the manual that came with the barcode checker.

## [Interface]

Set the RS-232C interface usage.

The options are as follows:

#### RS-232C

Use the RS-232C interface for communicating with computers.

#### RS-232C Reader

Select this when you connect a barcode checker with RS-232C interface connection for the barcode check function.



- A [RS-232C Reader] will be available in the future for expanded functions. If you are using a scanner manufactured by DATALOGIC, then you do not need to change this setting from [RS-232C] (initial value).
  - A message prompting you to restart the product will appear on the Online/Offline screen if you have made any changes. In such a case, reboot the product to apply the settings.
- 

### [Settings]

Set the barcode check function.

The setting items are as follows:

#### [Mode]

Select the check mode or disable the barcode check function.

Available only if you have selected [Continuous] in the [Print Mode] menu.

The options are as follows:

#### Disabled

Disable the barcode check function.

#### Readable

Check if the printed barcodes are readable.

To include barcodes that are not created by barcode commands (such as graphic data or preprinted barcodes) as the target of the barcode readability check, select [Settings] in [Set No. of Barcodes], and specify the number of barcodes per label in [Barcodes per Label].

#### Comparison

Check if the read results of the printed barcodes match the barcode data in the print data. This mode is for barcodes created by barcode commands.

### [Set No. of Barcodes]

Select the method to specify the number of barcodes per label.

Appears only if you have selected [Readable] in the [Mode] menu.

The options are as follows:

#### Command

Set barcodes created by barcode commands as the target of the barcode readability check.



## Setting

Include barcodes that are not created by barcode commands (such as graphic data or preprinted barcodes) as the target of the barcode readability check.

You need to specify the number of barcodes per label in [Barcodes per Label].

### [Barcodes per Label]

Specify the number of barcodes per label when you include barcodes which are not created by barcode commands as the target of the barcode readability check.

Appears only if you have selected [Readable] in the [Mode] menu. Available only if you have selected [Setting] in the [Set No. of Barcodes] menu.

The setting range is from 1 to 10.



- When excluding first barcode(s) from the check target by setting [Start Position], specify the number of barcodes without the excluded barcodes.

### [Start Position]

Adjust the position at which the barcode check starts (position of the barcode checker at which reading starts).

The barcode checker starts reading each media after the specified length passes from the printing start position.

This setting can be used to exclude first barcode(s) from the check target when multiple barcodes are printed on each media.

The setting range varies depending on the print resolution of the product.

The setting range is as follows:

Resolution	S84NX	S86NX
203 dpi (1 dot = 0.125 mm (0.0049"))	10 to 20000 dots	10 to 20000 dots
305 dpi (1 dot = 0.083 mm (0.0033"))	15 to 18000 dots	15 to 18000 dots
609 dpi (1 dot = 0.042 mm (0.0017"))	30 to 9600 dots	-



- You can change the units to dots, " (inches), or mm in the [System] > [Regional] > [Unit] menu.

### [VOID Print]

Set whether to print error marks on the media when a barcode reading error or barcode comparison error occurs.

6 x 6 mm (0.24" x 0.24") error marks are printed within the width of the print data image and in a length of up to 30 mm (1.18") from the trailing end of the label. The length varies depending on the image length of the print data and the operation mode.

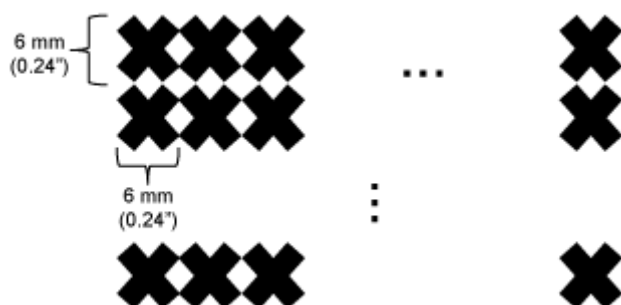

The options are as follows:

#### Enabled

If a reading error or comparison error occurs, the product prints error marks on the label without pausing.

After VOID printing, the product prints and checks the same label until it reaches the number of retries specified in [Retry Count]. If the error still occurs after the specified number of retries are done, the product pauses after VOID printing, and shows an error message on the display.

#### Disabled

If a reading error or comparison error occurs, the product pauses and shows an error message on the display.



- The VOID Print function is not available when the length of the print data is less than 8 mm (0.31").
  - The VOID printing length becomes 4 mm (0.16") shorter when the media sensor type is set to [Gap].
  - The VOID printing length becomes 1 mm (0.04") shorter when the media sensor type is set to [I-Mark].
  - The backfeed amount of VOID printing is 30.0 mm (1.18"). However, if the image length printed on the label to be checked is less than 30.0 mm (1.18"), the backfeed amount will be the same as the image length.
- 

#### [Retry Count]

Set how many times the product will try to print and check the same barcode after VOID printing when a barcode reading error or barcode comparison error occurs.

Appears only if you have selected [Enabled] in the [VOID Print] menu.

The setting range is from 0 to 10.

As long as the error continues to occur, the label is reprinted up to the number of times specified in this setting.

For example, if you set it to 0, if the error occurs while checking the first label, the product pauses and shows an error message after VOID printing. If set to 5, if the error continues to occur until the 6th label, the product pauses after VOID printing for the 6th label, and shows an error message.

## [Host Notification]

Set whether to return the barcode check results to the host from which the print data is sent.

The options are as follows:

### Enabled

Return the barcode check result of each label to the host as follows:

- When the check is successful: <STX>BV, OK<ETX>
- When the check is unsuccessful: <STX>BV, NG<ETX>

### Disabled

Do not return the barcode check results to the host.

## [Logs]

Manage the barcode check log data saved in the product.

Available only if there is barcode check log data in the product.

Note that new log data overwrites on older log data when the log file reaches its maximum size (1 MB).

### **Format and Contents of the Barcode Check Log Data**

The barcode check log data is created in the following format:

```
YYYY/MM/DD hh:mm:ss (ZZZ) [TTTTTTT] READING[IR]:SRSR:drrdr...<CR><LF>  
[RRRRRRR] COMMAND[IC]:SCSC:dcdc...<CR><LF>
```

Format ID	Description
YYYY	Year of the date when the barcode check was performed
MM	Month of the date when the barcode check was performed
DD	Day of the date when the barcode check was performed
hh	Hour of the time when the barcode check was performed
mm	Minute of the time when the barcode check was performed
ss	Second of the time when the barcode check was performed
ZZZ	Time zone
TTTTTTT	The total number of printed labels after the product is powered on. *When the total number of printed labels becomes greater than an 8-digit number, the output digit will increase.
IR	The number of read data received after reaching the position at which the check starts. *When the check result is "IGNORED", this shows "00".

Format ID	Description	
SRSR	Size of read data (bytes)	
drdr...	Read data	
RRRRRRR	Check result	
	SUCCESS	<ul style="list-style-type: none"> <li>In readable mode, this means everything is correct.</li> <li>In comparison mode, this means that the read data and print data match.</li> </ul>
	FAILURE	<ul style="list-style-type: none"> <li>In readable mode, this means that the barcode checker could not read the number of printed barcode data.</li> <li>In comparison mode, this means that the read data and print data do not match.</li> </ul>
	IGNORED	This means that the data is read during a period other than from the start to the end of checking, while the product is active.
IC	The amount of print data as a check target *If the check result is "IGNORED", this becomes "--".	
SCSC	Size of print data (bytes) *If the check result is "IGNORED", this becomes "----".	
dcdc...	Print data *If the check result is "IGNORED", nothing is output.	

The setting items are as follows:

### [Copy]

Copy the barcode check log data to the USB memory.

Available only if there is barcode check log data in the product and if you have installed the USB memory.



- Be sure to perform a virus check on the USB memory before connecting it to the product. SATO Corporation shall not be held responsible for any product malfunctions caused by a virus spread via USB memory.

Press the  button to copy the log data to the USB memory.

### [Remove]

Delete the barcode check log file.

Available only if there is barcode check log data in the product.

Press the  button to delete the log data.

## [Clone]

Copy the current product settings and the installed data to the USB memory.

Available only if you have installed the USB memory.



- Be sure to perform a virus check on the USB memory before connecting it to the product. SATO Corporation shall not be held responsible for any product malfunctions caused by a virus spread via USB memory.
- 

This function is useful to transfer the settings of a product you are replacing to continue using them in a new product, or if you are setting up multiple products with the same settings.

The options are as follows:

### Excl. LAN/Wi-Fi/IP

Copy the product settings and data, excluding network information, to the USB memory. This is useful when you set up multiple products, that are already connected to a network, with the same settings.

### Incl. LAN/Wi-Fi

Copy the product settings and data, including network information (excluding the IP address), to the USB memory. This is useful when you set up multiple products to be connected to the same network with the same settings.

### Incl. LAN/Wi-Fi/IP

Copy the product settings and data, including network information (including the IP address), to the USB memory. This is useful when transferring the settings of a product you are replacing to continue using them in a new product.

## [Clone Notice Setting]

Enable or disable the clone notification.

By enabling this, a message prompting you to create a clone appears if the product's settings have been changed.

Available only if you have connected the USB memory to the USB connector (Type A) on the back of the product.



- Be sure to perform a virus check on the USB memory before connecting it to the product. SATO Corporation shall not be held responsible for any product malfunctions caused by a virus spread via USB memory.
- 

The options are as follows:

### Enabled

Enable the clone notification.

### Disabled

Disable the clone notification.

The message appears after you change settings, when you go from the setting menu to the Offline screen.

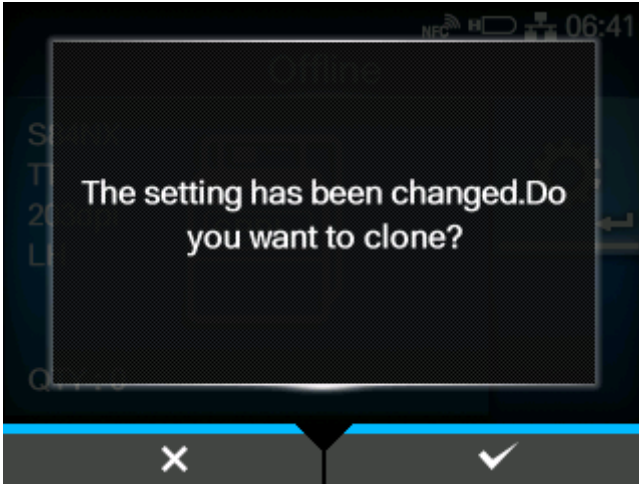

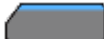
Press the  button to move to the [Clone] settings screen.



- To use this function, connect the USB memory to the connector on the back of the product. If it is connected to the connector on the side of the product, this function does not work.
- When this function is enabled, the USB connector (Type A) on the back is dedicated to the clone function, and functions other than the clone function cannot be used.

### [Support Info]

Save various information about the product, such as attached options, serial number, application versions and settings configuration, in a text file (.txt) to the USB memory.

Available only if you have installed the USB memory.



- Be sure to perform a virus check on the USB memory before connecting it to the product. SATO Corporation shall not be held responsible for any product malfunctions caused by a virus spread via USB memory.

By selecting [Support Info] and pressing the  button, the support information is saved to the USB memory.

After saving is complete, the saved location is displayed.

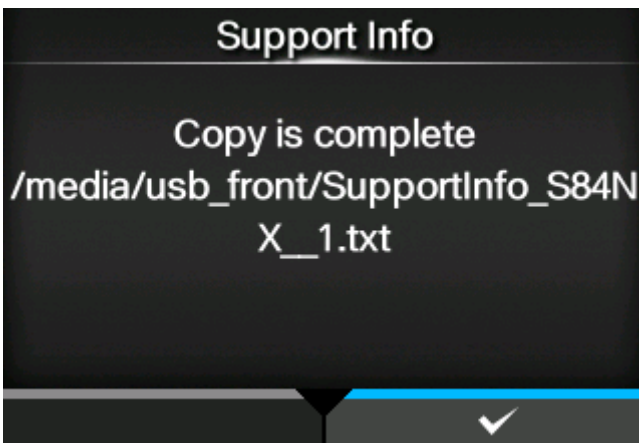

Press the  button to complete.

## [Logging Function]

Save the log data.

The setting items are as follows:

### [Enabled]

Enable or disable the logging function.

The options are as follows:





#### Enabled

Enable the logging function. When this function is enabled, the log data is saved when powering off the product.





#### Disabled

Disable the logging function.



- The logging function does not operate when powering off is done by using the power (I/O) switch. Pressing and holding the four arrow (  /  /  /  ) buttons at the same time for about 3 seconds saves log data and turns off the power.

Saving the log may take a long time. Wait until the product is powered off.

- When powering off the product with the four arrow (  /  /  /  ) buttons to use the logging function, use the same buttons to power on the product again.

If the product is powered off with the four arrow buttons and then powered on again with the power (I/O) switch, the product will not start until discharge process is complete (for approximately 2 minutes).

- While the log data is being saved, a message that says "Log Saving" appears on the screen.
- The product stores log data for the last five times the product was powered off.
- The types of log data that are saved are as follows:
  - Key events
  - Analysis status
  - System logs and settings
  - Shared memory (including receive buffer)
  - Operational logs for the barcode scanner

---

### [Save]

Save the log data to the USB memory.

Available only if there is log data in the product and if you have installed the USB memory.



- Be sure to perform a virus check on the USB memory before connecting it to the product. SATO Corporation shall not be held responsible for any product malfunctions caused by a virus spread via USB memory.
-

Press the  button to copy the log data to the USB memory.



- The saved log data is strictly for the use of SATO authorized service personnel.
- 

### [Remove]

Delete the log data.

Press the  button to delete the log data.

### [Startup Guide]

The startup guide is a function to help you through the initial product settings (such as setting date and time, and loading the ribbon and media).

Enable or disable the startup guide.

The options are as follows:

#### Enabled

Enable the startup guide.

#### Disabled

Disable the startup guide.

If you have selected [Enabled], the startup guide appears when you power on the product.





## [Information] Menu

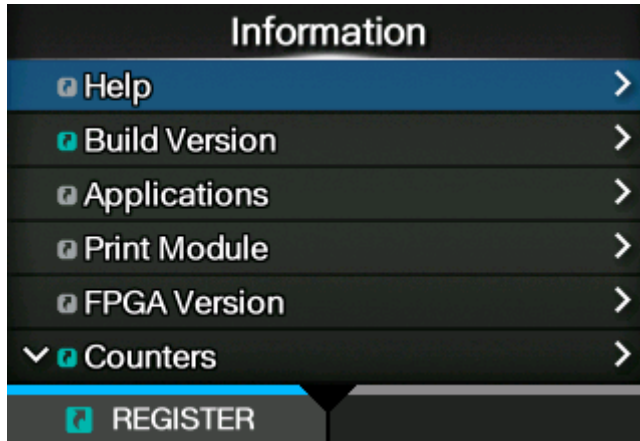

The following settings are available in the [Information] menu:

### [Help]

Shows the guidance video.

You can view the video for loading the media and ribbon, the cleaning method and replacement method of consumables.

The video corresponding to the orientation of your product (Standard/Left-hand type or Opposite/Right-hand type) will be displayed.

The list of videos are as follows:

### [Install/Replace Media]

Shows the video for loading or replacing the media and ribbon.

The items are as follows:

#### [Install Paper]

Shows the video for loading the media.

#### [Install Ribbon]

Shows the video for loading the ribbon.

Available only for the combined direct thermal/thermal transfer model.

#### [Replace Paper]

Shows the video for replacing the media.

#### [Replace Ribbon]

Shows the video for replacing the ribbon.

Available only for the combined direct thermal/thermal transfer model.

### [Cleaning]

Shows the video of the cleaning method.

The items are as follows:

#### [Cleaning(Print head)]

Shows the video for cleaning the print head.

#### [Cleaning(Roller)]

Shows the video for cleaning the rollers, such as platen roller, pressure roller, and feed roller.

#### [Cleaning(Paper path)]

Shows the video for cleaning the routes for the media.

#### [Cleaning(Ribbon path)]

Shows the video for cleaning the routes for the ribbon.

Available only for the combined direct thermal/thermal transfer model.

### [Replace Parts]

Shows the video for replacing the parts.

The items are as follows:

#### [Replace Printhead]

Shows the video for replacing the print head.

#### [Replace Platen]

Shows the video for replacing the platen roller.

#### [Replace Pressure roller]

Shows the video for replacing the pressure roller.

#### [Replace Feed roller]

Shows the video for replacing the feed roller.

#### [Replace Pressure plate]

Shows the video for replacing the pressure plate.

#### [Replace Fan filter]

Shows the video for replacing the fan filter.

### [Build Version]

Shows the information and version of the product.

### Name

Shows the name of the build version.

### Date

Shows the build date.

### Checksum

Shows the checksum of the build version.

### Kernel Version

Shows the kernel version of the product.

### Boot Version

Shows the boot version of the product.

## [Applications]

Shows the versions of the applications installed in the product, such as printer languages.

## [Installation Log]

Show or clear the installation log data in the product.

Press the  button (CLEAR) to clear the selected log data.



- This screen does not appear if there is no log data in the product.
- 

The setting items are as follows:

## [RPM log]

Shows a list of RPM log files containing three sections: installed, updated and obsolete.

The RPM log file is created after installing a pkg-file containing rpm-files.

## [System Restore]

Shows the system restore log.

The system restore log file is created after installing a pkg-file that caused a state in which the product's operator panel cannot be operated.

## [Print Module]

Shows information about the print module on the product.

The items are as follows:

### Boot

Shows the Boot firmware version.

Main

Shows the Main firmware version.

[FPGA Version]

Shows the FPGA version on the product.

The item is as follows:

Name

Shows the FPGA version.

[Counters]

Shows information about the counters on the product.



- Only SATO authorized service personnel are permitted to clear the counter.
- 

The setting items are as follows:

[Head]

Shows information about the head counter on the product.

Life

Shows the current print distance.

Head 1

Head 2

Head 3

[Head 1] shows the current print distance. When you replace the print head, the value of [Head 2] appears in [Head 3] and the value of [Head 1] appears in [Head 2]. [Head 1] will start to count from 0 again.

[Dispenser]

Shows the current print distance in dispenser mode.

[Belt(Gear Box)]

Shows the current distance the gearbox timing belt has advanced the media in the eject direction.

Belt 1

Belt 2

### Belt 3

[Belt 1] shows the current distance the belt has fed.

When you replace the belt and the counter is cleared, the value of [Belt 2] appears in [Belt 3] and the value of [Belt 1] appears in [Belt 2]. [Belt 1] will start to count from 0 again.

### **[Belt(Ribbon)]**

Shows the current distance the ribbon timing belt has advanced the media in the eject direction.

#### Belt 1

#### Belt 2

#### Belt 3

[Belt 1] shows the current distance the belt has fed.

When you replace the belt and the counter is cleared, the value of [Belt 2] appears in [Belt 3] and the value of [Belt 1] appears in [Belt 2]. [Belt 1] will start to count from 0 again.

### **[IPv4 Address]**

Shows the IPv4 address.

### **[IPv6 Address]**

Shows the IPv6 address.



- When Wi-Fi Direct is active, this IPv6 address screen does not appear.
- 

### **[LAN MAC]**

Shows the MAC address of the LAN.

Appears only if LAN is the active interface.

### **[Wi-Fi MAC]**

Shows the MAC address of the wireless LAN.

Appears only if you have installed the optional wireless LAN and Wi-Fi is the active interface.

### **[Wi-Fi Region]**

Shows the region information of the wireless LAN.

Appears only if you have installed the optional wireless LAN and Wi-Fi is the active interface.

### [Wi-Fi Status]

Shows the status of the wireless LAN.

Appears only if you have installed the optional wireless LAN and Wi-Fi is the active interface.

### [Wi-Fi Direct]

Shows the connection information of Wi-Fi Direct.

Appears only if Wi-Fi Direct is the active interface and you are connected using Wi-Fi Direct.

### [Wi-Fi Versions]

Shows the version of the wireless LAN.

Appears only if you have installed the optional wireless LAN and Wi-Fi is the active interface.

### [Wi-Fi Module]

Shows the name of the installed wireless LAN module.

Appears only if the optional wireless LAN is installed and the Wi-Fi interface is selected.

### [USB Serial]

Shows the USB serial number.

# Configuring the Product Settings from a Web Browser

## Accessing to the Web Configuration Page

The product can be operated through a web configuration page using any browser.

With an Ethernet LAN or WLAN connection, users can remotely get information from the product or perform the product settings.



- You need the product's IP address to access the web configuration page. The product's IP address can be checked in [Settings] > [Information] > [IPv4 Address].
- If the product's [Settings] > [Interface] > [Network] > [Advanced] > [Firewall] > [Enable] menu is set to [Enabled], [Settings] > [Interface] > [Network] > [Advanced] > [Firewall] > [Allow Services And Ports] > [WebConfig] must be set to [Enabled].

### 1. Open up the browser and enter the product's URL.

If the product's IP address is 192.168.143.123, enter the following URL: https://192.168.143.123

When a security certificate is prompted, you must acknowledge and click Continue.

The web configuration page for the product appears. On the upper right (1) of each page, the model name, current resolution and MAC address are shown.

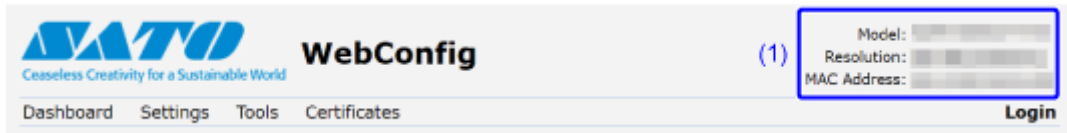

### 2. Log in.

You can view a part of the [Dashboard] page without logging in.

- a. Click [Login] (2).

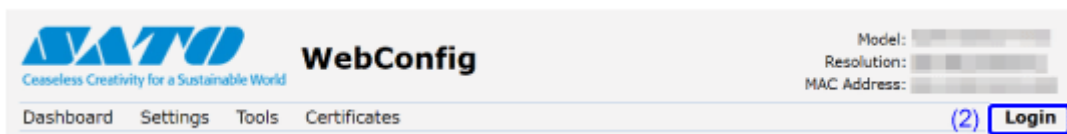

- b. Select [settings] for the user, enter the password, and click [Login].

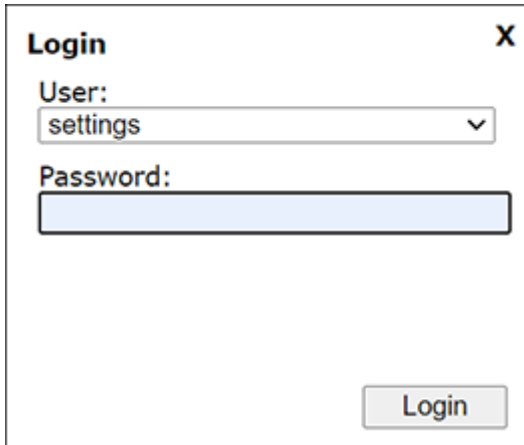

The default setting for user is [settings], and for password is "USB serial number (8 digits of uppercase English letters and numerals) +user". You can confirm the USB serial number in the following ways.

- [USB Serial] item on [Device] on the [Dashboard] page of the web configuration page
- [Information] > [USB Serial] menu
- Test print results executed by [Tools] > [Test Print] > [Configure List] menu

- 3. Click on the page (3) you want to view.

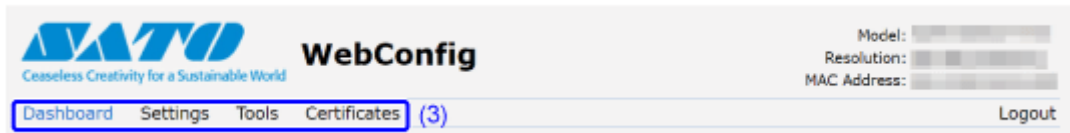



## Dashboard

[Dashboard] is the default page for the web configuration page. Each section shows specific information or the current status of the product.

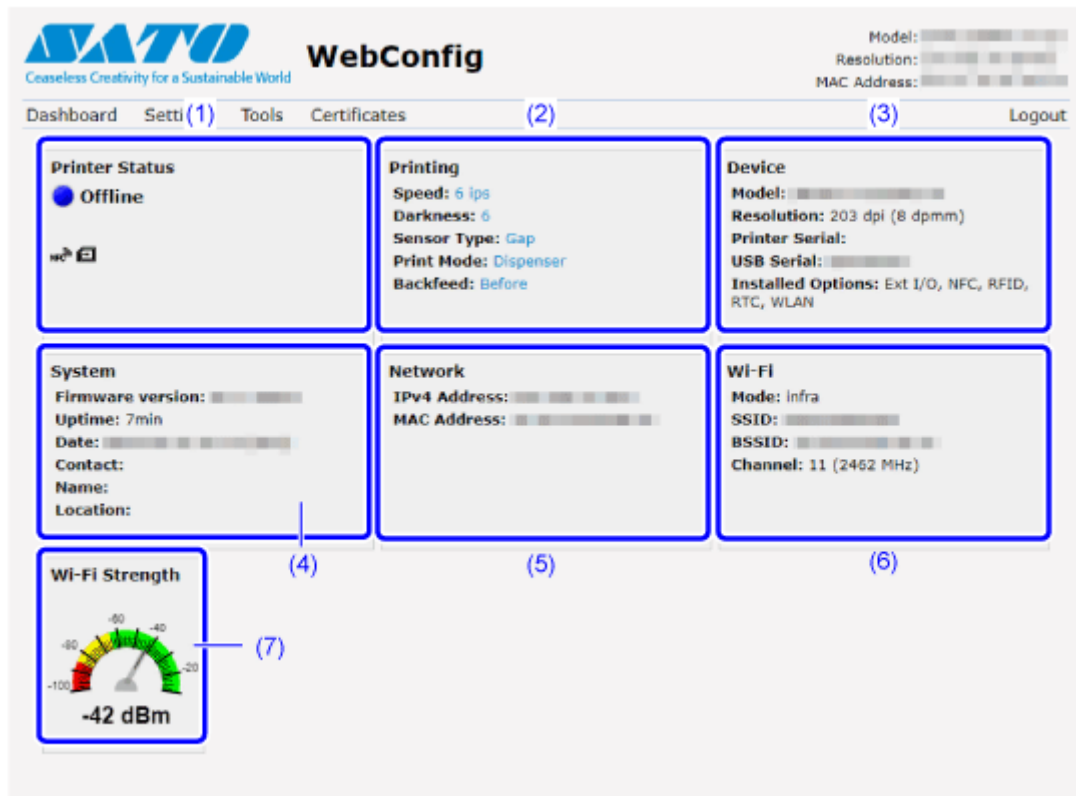

(1) [Printer Status]

Shows the current state (online, offline, error) and current status icons.

(2) [Printing]

Shows the print speed, darkness, sensor, print mode and backfeed setting.

(3) [Device]

Shows the model, current resolution and options that are installed.

(4) [System]

Shows the current firmware version, uptime, SNMP contact, name and location.

(5) [Network]

Shows the current IP address and MAC address of the active interface.



- Click [Login] to log in for viewing.

The default setting for user is [settings], and for password is "USB serial number (8 digits of uppercase English letters and numerals) +user". You can confirm the USB serial number in the following ways.

- [USB Serial] item on [Device] on the [Dashboard] page of the web configuration page
  - [Information] > [USB Serial] menu
  - Test print results executed by [Tools] > [Test Print] > [Configure List] menu
- 

#### (6) [Wi-Fi]

Shows the current Wi-Fi setting.

---



- Click [Login] to log in for viewing.

The default setting for user is [settings], and for password is "USB serial number (8 digits of uppercase English letters and numerals) +user". You can confirm the USB serial number in the following ways.

- [USB Serial] item on [Device] on the [Dashboard] page of the web configuration page
  - [Information] > [USB Serial] menu
  - Test print results executed by [Tools] > [Test Print] > [Configure List] menu
- This information is shown only if Wi-Fi is available and active.
- 

#### (7) [Wi-Fi Strength]

Shows the current Wi-Fi communication strength.

---



- If the product is P2P GO, the Wi-Fi Strength will not be shown.
-

## Settings

The settings equivalent to the product's Settings mode can be performed on the browser.



- Login is required to view the [Settings] page. Click [Login] to log in before opening the [Settings] page.

The default setting for user is [settings], and for password is "USB serial number (8 digits of uppercase English letters and numerals) +user". You can confirm the USB serial number in the following ways.

- [USB Serial] item on [Device] on the [Dashboard] page of the web configuration page
- [Information] > [USB Serial] menu
- Test print results executed by [Tools] > [Test Print] > [Configure List] menu



### (1) [Printing]

You can do the settings equivalent to the [Printing] menu in the Settings mode.

### (2) [Interface]

You can do the settings equivalent to the [Interface] menu in the Settings mode.

### (3) [Applications]

You can do the settings equivalent to the [Applications] menu in the Settings mode.

### (4) [System]

You can do the settings equivalent to the [System] menu in the Settings mode.

### (5) [Tools]

You can do the settings equivalent to the [Tools] menu in the Settings mode.

## (6) [Information]

You can do the settings equivalent to the [Information] menu in the Settings mode.

The screen below is the example of [Printing] page.

**ATTO** WebConfig  
Ceaseless Creativity for a Sustainable World

Model: [REDACTED]  
Resolution: [REDACTED]  
MAC Address: [REDACTED]

Dashboard Settings Tools Certificates Logout

**Printing**

Label Length: 20000 1 <-> 20000 dot  
Label Width: 832 1 <-> 832 dot  
Auto Measure:   
Printing Mode: Use Ribbon  
Ribbon Near End:   
Speed: 8  
Sensor Type: Gap

▶ **Micro Label Print Mode**

Print Mode: Dispenser  
Backfeed: Before  
Darkness: 8

▶ **Imaging**

▶ **Advanced**



- If you have changed the RFID antenna position in the [Interface] > [RFID] > [Antenna Position] menu on the Web Configuration Page, restart the product. Just changing the setting values does not affect the position of the antenna.
- If a message prompting you to restart the product appears at the top of the page, click [Reboot printer] to reboot the product to apply the settings.

**ATTO** WebConfig  
Ceaseless Creativity for a Sustainable World

Model: [REDACTED]  
Resolution: [REDACTED]  
MAC Address: [REDACTED]

Dashboard Settings Tools Certificates Logout

Restart to apply changes.  
Reboot printer

## Tools

Various settings and operations can be performed in this page: installing certificates for authentication, checking the log, and test printing.



- Login is required to view the [Tools] page. Click [Login] to log in before opening the [Tools] page.

The default setting for user is [settings], and for password is "USB serial number (8 digits of uppercase English letters and numerals) +user". You can confirm the USB serial number in the following ways.

- [USB Serial] item on [Device] on the [Dashboard] page of the web configuration page
- [Information] > [USB Serial] menu
- Test print results executed by [Tools] > [Test Print] > [Configure List] menu

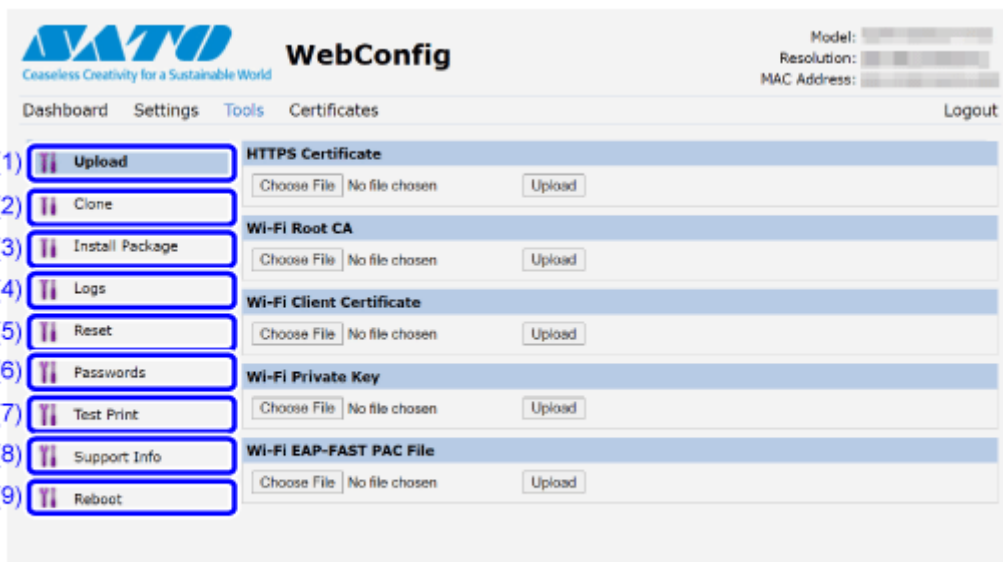

### (1) [Upload]

Click [Choose File] of the certificate you want to install.

Select the certificate file from the list and click [Upload], and the authentication file will be installed.

### (2) [Clone]

You can do the setting equivalent to [Tools] > [Clone] in the Settings mode. Copy the current product settings and the data that is installed.

### (3) [Install Package]

Contact your SATO reseller or technical support for more information of the package file.

### (4) [Logs]

List all log files in the log directory. Users can click to download the file.

(5) [Reset]

You can do the setting equivalent to [Tools] > [Reset] in the Settings mode. Initialize the setting values and data saved on the product.

(6) [Passwords]

You can do the setting equivalent to [System] > [Password] > [Change Password] in the Settings mode. Change the each password of the product.

(7) [Test Print]

You can do the setting equivalent to [Tools] > [Test Print] in the Settings mode. Perform a test print.

(8) [Support Info]

You can do the setting equivalent to [Tools] > [Support Info] in the Settings mode.

You can also get a screenshot of the current product display and an image of the last printout.

(9) [Reboot]

Reboot the product.

## Certificates

Shows the root certificate authority and client certificates installed on the product.



- Login is required to view the [Certificates] page. Click [Login] to log in before opening the [Certificates] page.

The default setting for user is [settings], and for password is "USB serial number (8 digits of uppercase English letters and numerals) +user". You can confirm the USB serial number in the following ways.

- [USB Serial] item on [Device] on the [Dashboard] page of the web configuration page
- [Information] > [USB Serial] menu
- Test print results executed by [Tools] > [Test Print] > [Configure List] menu

The screenshot shows the SATO WebConfig interface. At the top left is the SATO logo with the tagline "Ceaseless Creativity for a Sustainable World". To the right is the "WebConfig" title. In the top right corner, there are fields for "Model:", "Resolution:", and "MAC Address:". Below the title bar is a navigation menu with "Dashboard", "Settings", "Tools", and "Certificates" (which is highlighted). A "Logout" link is also present. The main content area is titled "Installed Certificates" and features a blue header for "HTTPS (Pre-installed)". Below this, the details of a certificate are displayed in a monospaced font:

```
Certificate:
Data:
  Version: 3 (0x2)
  Serial Number:
    a0:0e:9d:f7:05:2e:c6:34
  Signature Algorithm: sha256WithRSAEncryption
  Issuer: C=SE, ST=Vastergotland, L=Gothenburg, O=SATO Techno Lab Europe AB
  Validity
    Not Before: Mar 24 08:31:09 2016 GMT
    Not After : Mar 24 08:31:09 2026 GMT
  Subject: C=SE, ST=Vastergotland, L=Gothenburg, O=SATO Techno Lab Europe AB
  Subject Public Key Info:
    Public Key Algorithm: rsaEncryption
    Public-Key: (2048 bit)
    Modulus:
      00:a4:00:01:c4:76:c0:b4:3d:2f:47:b9:e0:71:0b:
      c1:06:00:14:27:76:dd:7e:97:71:4f:f7:35:fc:1f:
      57:f5:41:97:af:3e:ee:0c:5b:80:a7:00:56:b5:bf:
      2a:9a:81:f1:5d:bd:a2:18:c3:2c:39:5b:53:fc:e9:
      6d:a7:d5:ed:03:cf:c8:89:85:ec:5c:78:1c:be:ee:
      65:7b:e0:a3:9e:0b:1a:b4:53:08:38:98:81:f1:6e:
      d0:89:32:9c:15:9d:d5:8d:51:1f:bb:e0:34:66:fe:
      ba:6f:0a:9a:4e:72:5a:d4:74:62:61:c9:1a:59:e9:
      cb:0b:a8:09:82:4d:f3:6c:83:a7:9f:7a:39:b2:94:
```



- The client certificate that is a PFX (PKCS #12) file will not be shown.

# Adjusting the Product

## Printable Area

The printable area of the product is as follows:

### S84NX

- **For Standard/Left-Hand Type**

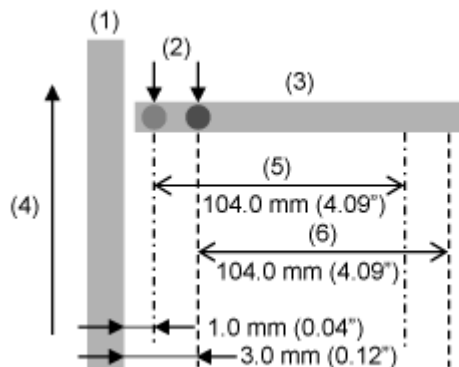

- (1) Frame
- (2) Base reference position for printing
- (3) Print head
- (4) Media feed direction
- (5) Printable area (Left-justify)
- (6) Printable area (Standard)

- **For Opposite/Right-Hand Type**

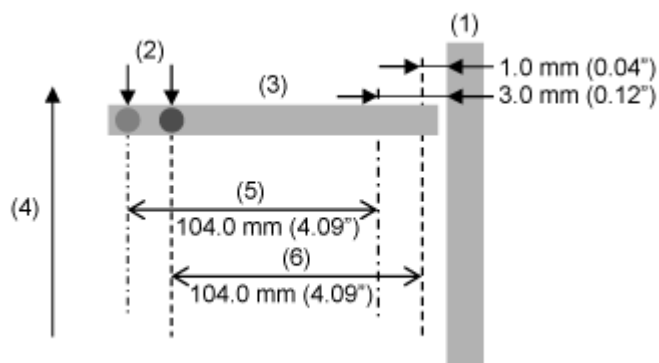

- (1) Frame
- (2) Base reference position for printing
- (3) Print head
- (4) Media feed direction



- (5) Printable area (Standard)
- (6) Printable area (Left-justify)

**S86NX**

- **For Standard/Left-Hand Type**

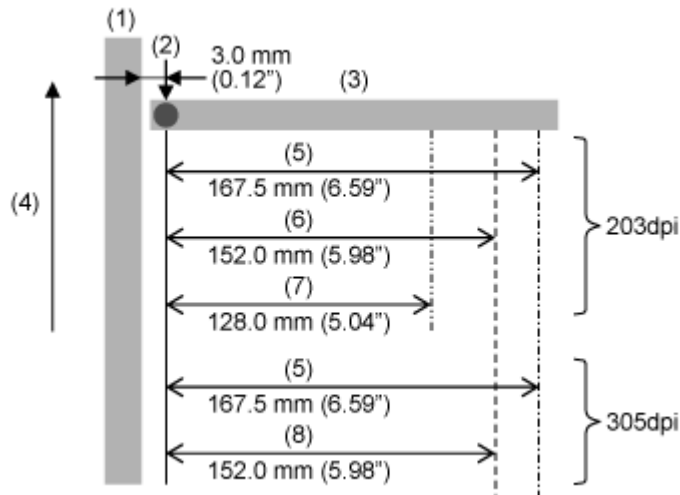

- (1) Frame
- (2) Base reference position for printing
- (3) Print head
- (4) Media feed direction
- (5) Printable area (Standard)
- (6) Printable area (M8460Se compatible)
- (7) Printable area (M8485Se compatible)
- (8) Printable area (M8465Se compatible)

- **For Opposite/Right-Hand Type**

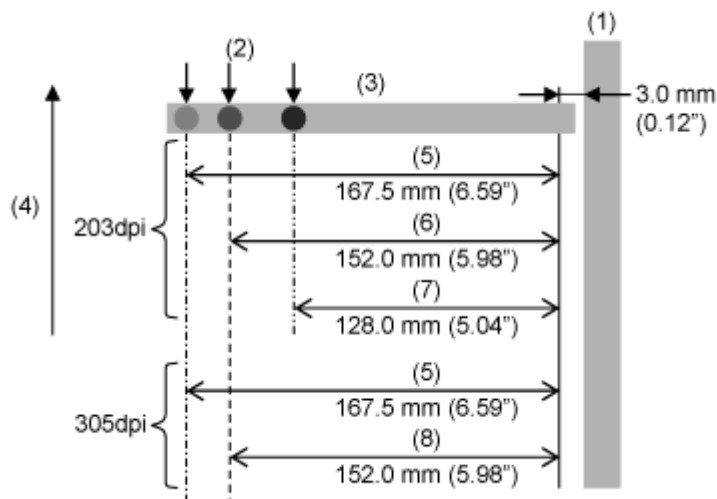

- (1) Frame
- (2) Base reference position for printing
- (3) Print head
- (4) Media feed direction
- (5) Printable area (Standard)
- (6) Printable area (M8460Se compatible)
- (7) Printable area (M8485Se compatible)
- (8) Printable area (M8465Se compatible)

## Media Sensor Positions and Media Stop Positions

The positions of the media sensors and the media stop positions are as follows:

### Standard/Left-Hand Type

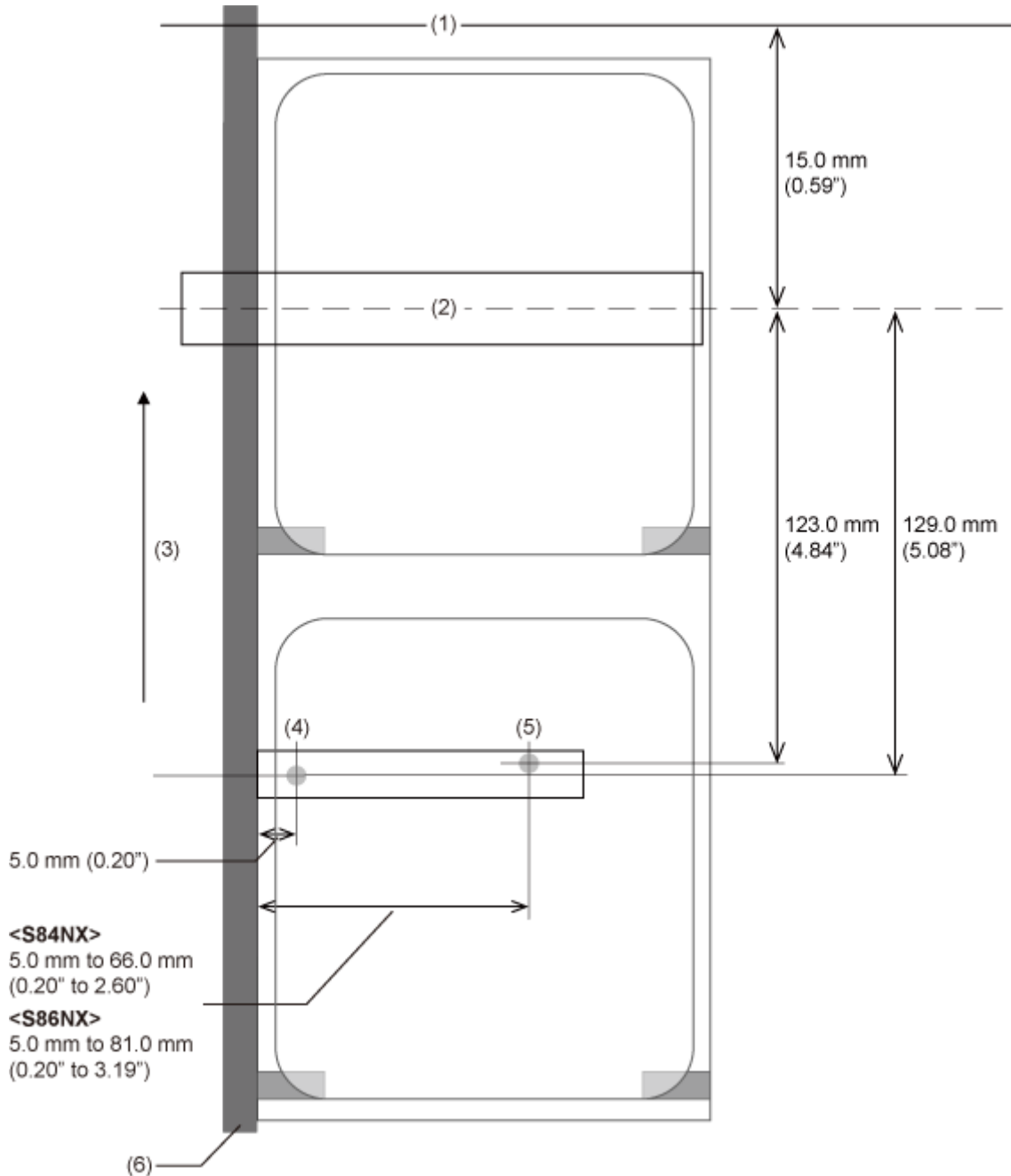

(1) Media stop position for dispense operation

(2) Print head

(3) Media feed direction

(4) I-mark sensor

(5) Gap sensor

(6) Frame

Opposite/Right-Hand Type

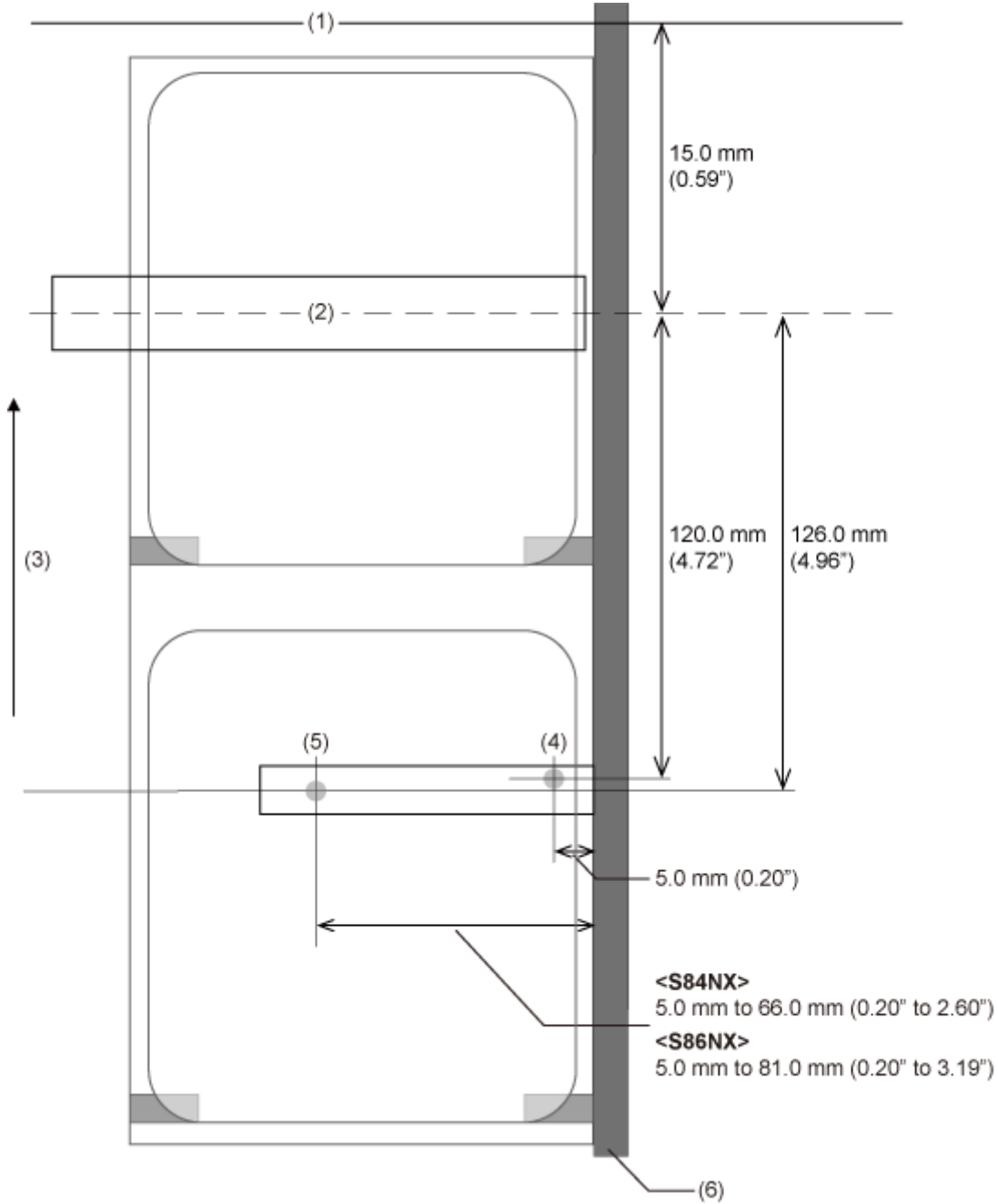

- (1) Media stop position for dispense operation
- (2) Print head
- (3) Media feed direction
- (4) I-mark sensor
- (5) Gap sensor
- (6) Frame

## Flow of Printing Operations

---

### Printing Operations

Printing operations vary depending on the combination of the following settings.

- Print Mode
- Enabled/disabled media sensor
- Backfeed operation
- With/without pulse input (from external signal (EXT) interface)
- Enabled/disabled head check

## Operations in Continuous Mode

### Continuous Mode, with Media Sensor Enabled, and without Pulse Input

#### Operation

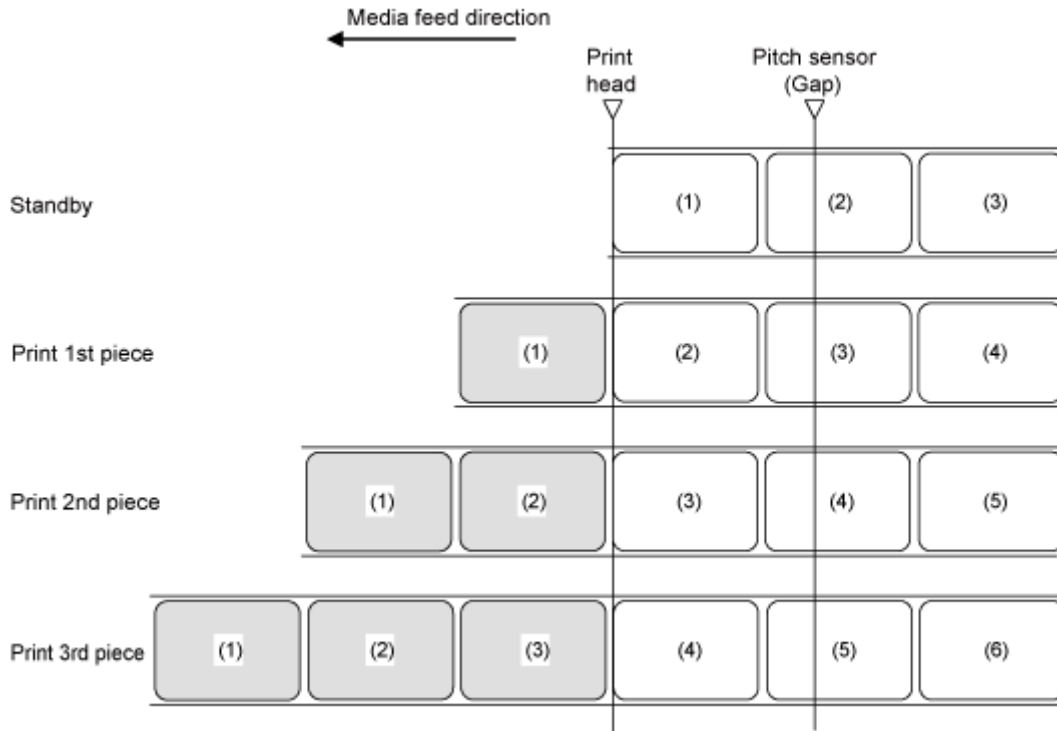

- The figure above shows the reference position when the Gap sensor is used.

#### Timing Chart (Without Head Check)

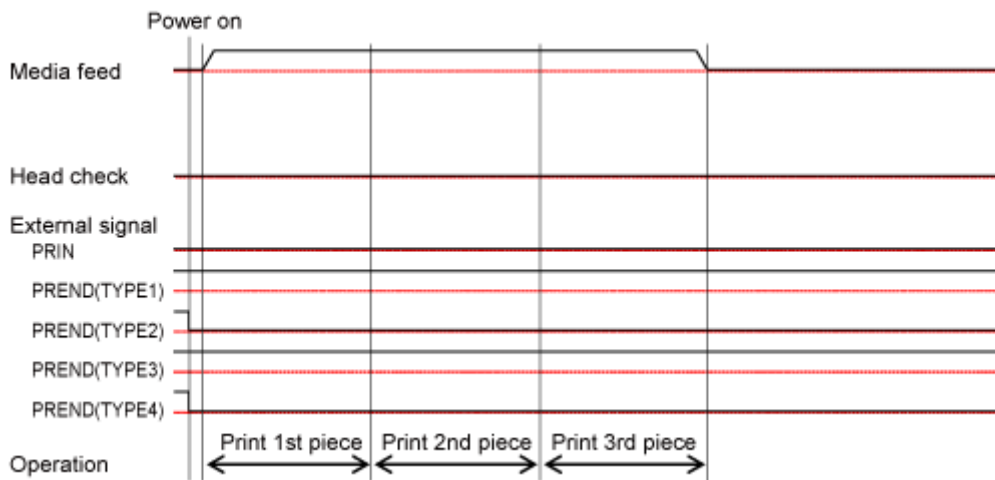

### Timing Chart (With Head Check)

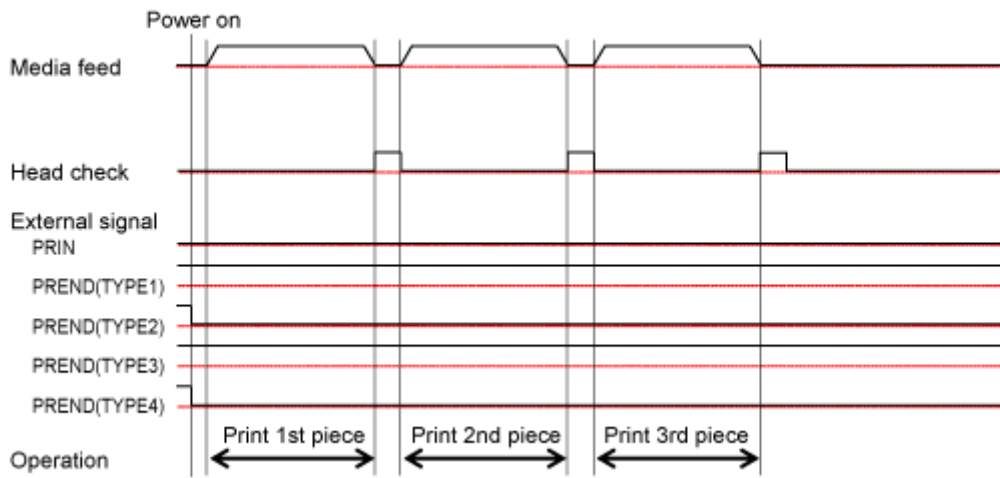

## Continuous Mode, with Media Sensor Disabled, and without Pulse Input

### Operation

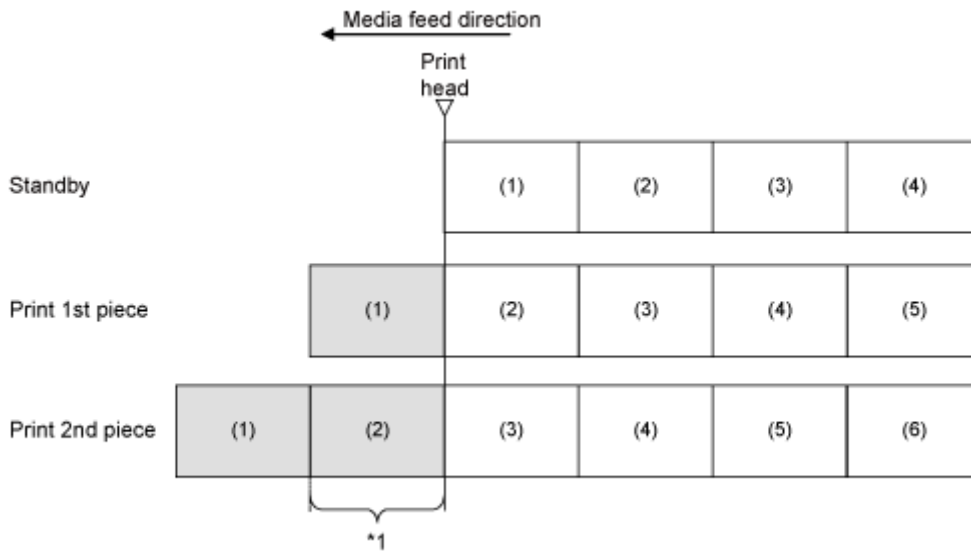

\*1 The product will feed the actual vertical print size of media. However, if you specify the End Position (<EP>) command, the product will feed the specified vertical size of media.



- The spaces between each layout varies depending on the print speed.

In the figure above, as you set the print speed faster, the space between the first and second print becomes wider.

### Timing Chart (Without Head Check)

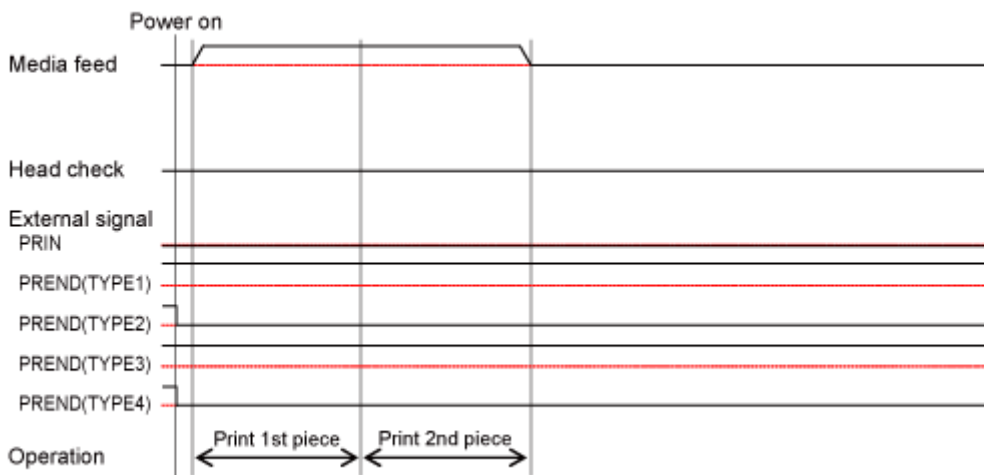



### Timing Chart (With Head Check)

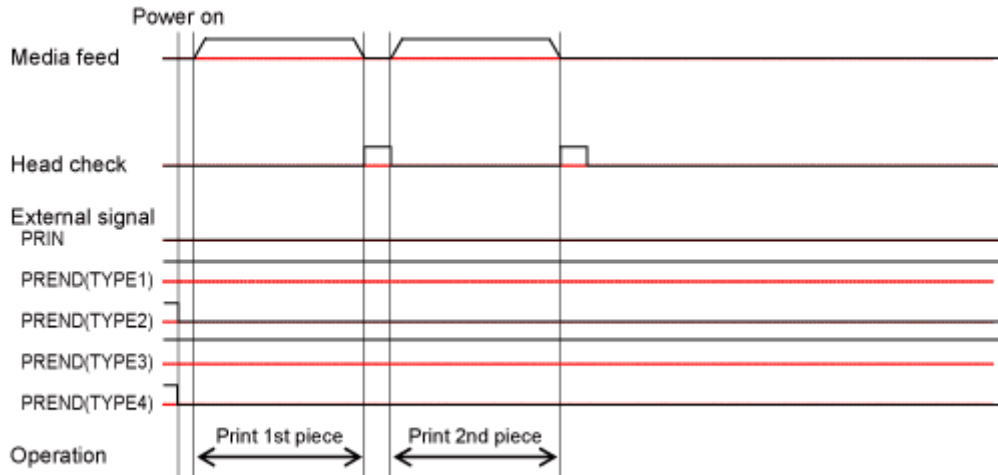

- Do feeding while pressing the  button in the Offline mode. However, the PREND (Print End) signal will not change.

## Continuous Mode, with Media Sensor Enabled, and with Pulse Input

### Operation

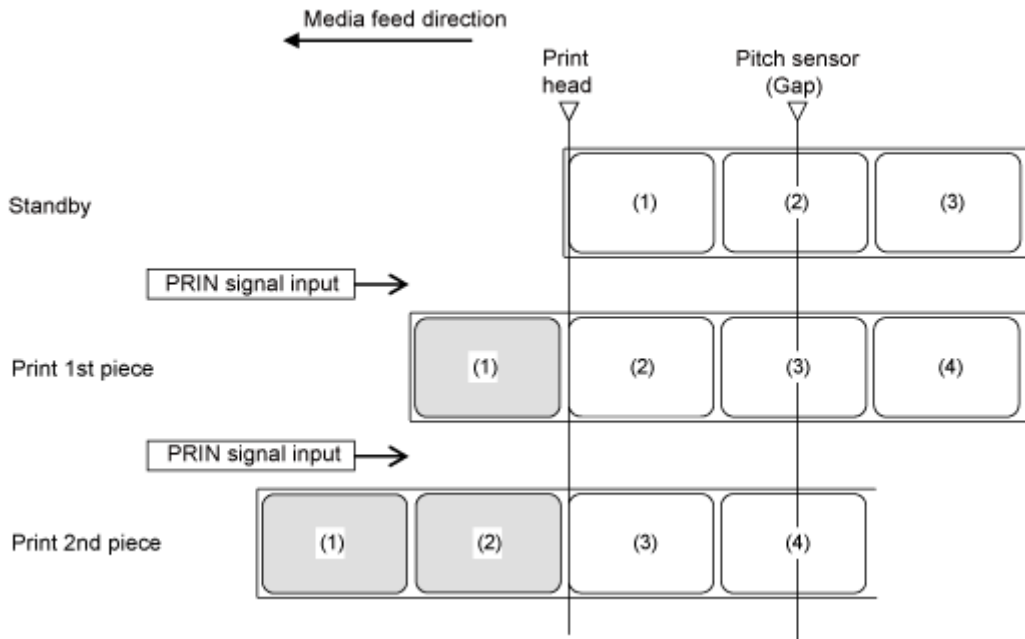

- The figure above shows the reference position when the Gap sensor is used.

### Timing Chart (Without Head Check)

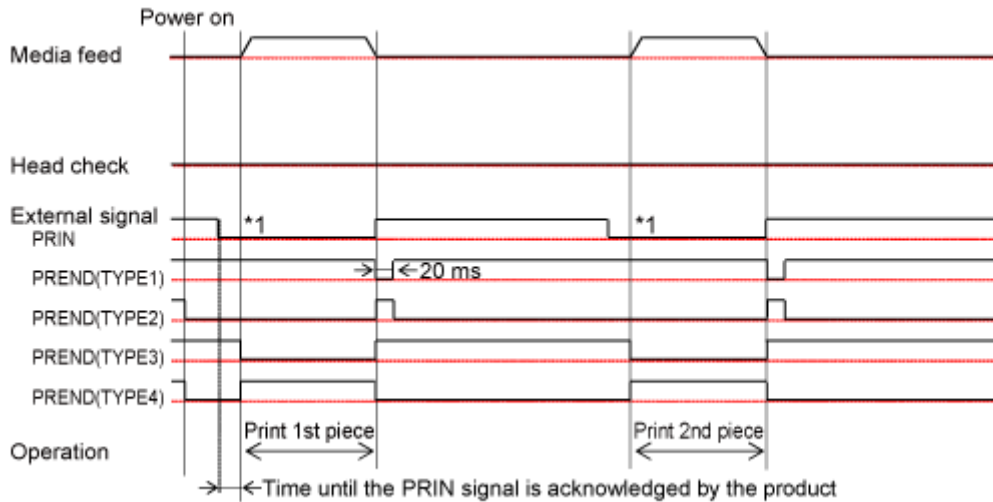

### Timing Chart (With Head Check)

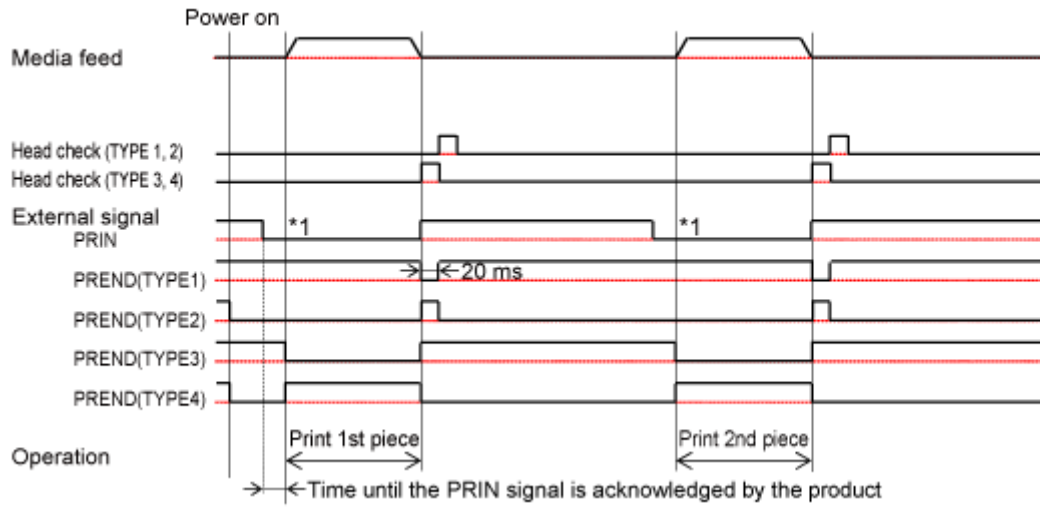

\*1 Keep the PRIN (Print Start) signal until the PREND (Print End) signal is outputted.

## Continuous Mode, with Media Sensor Disabled, and with Pulse Input

### Operation

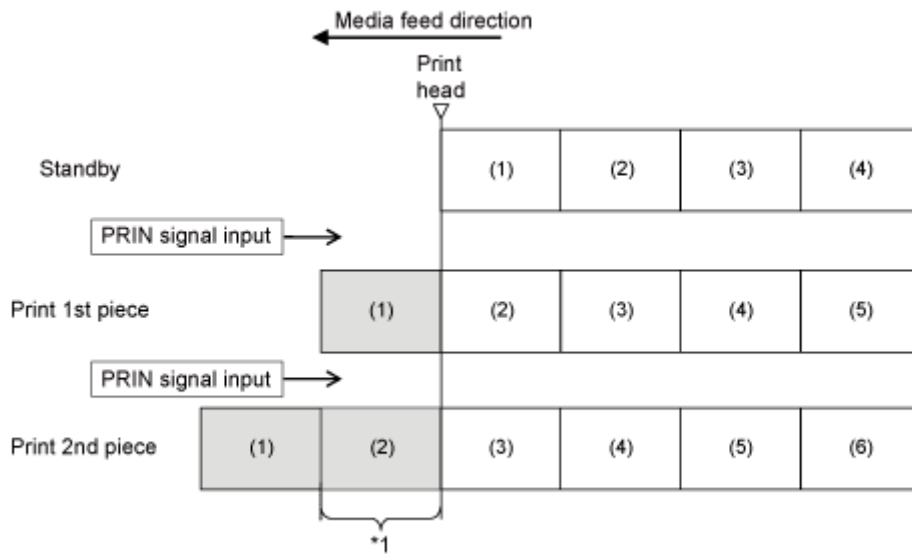

\*1 The product will feed the actual vertical print size of media. However, if you specify the End Position (<EP>) command, the product will feed the specified vertical size of media.



- The spaces between each layout varies depending on the print speed.

In the figure above, as you set the print speed faster, the space between the first and second print becomes wider.

### Timing Chart (Without Head Check)

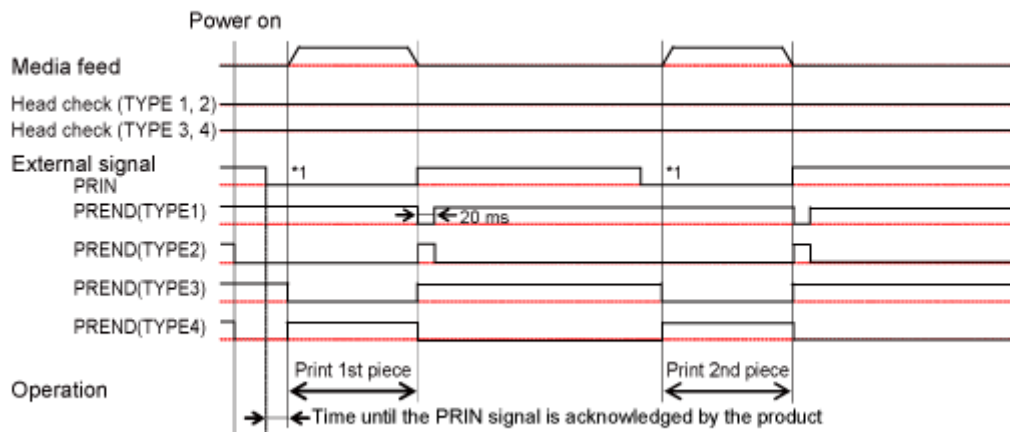

## Timing Chart (With Head Check)

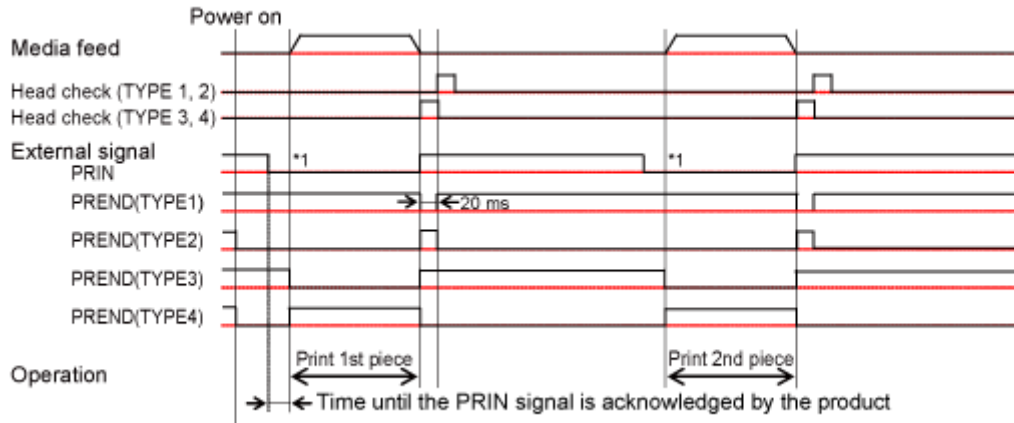

\*1 Keep the PRIN (Print Start) signal until the PREND (Print End) signal is outputted.

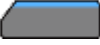

- Do feeding while pressing the  button in the Offline mode. However, the PREND (Print End) signal will not change.

## Operations in Dispenser Mode

### Dispenser Mode, Backfeed After Printing, with Media Sensor Enabled, and with Pulse Input

#### Operation

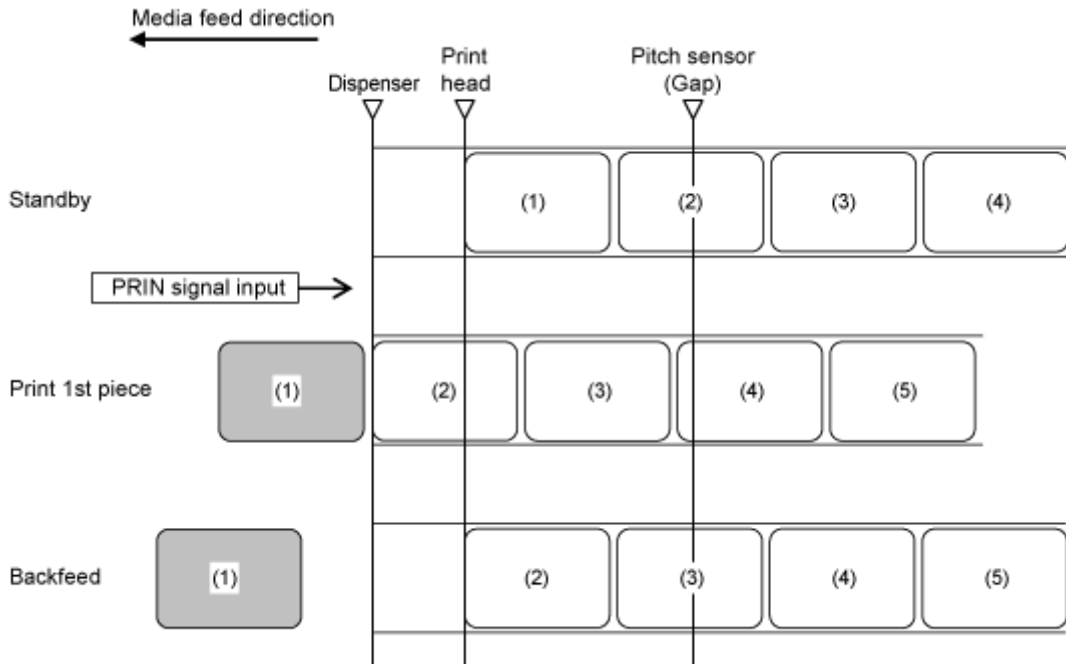

- The figure above shows the reference position when the Gap sensor is used.

#### Timing Chart (Without Head Check)

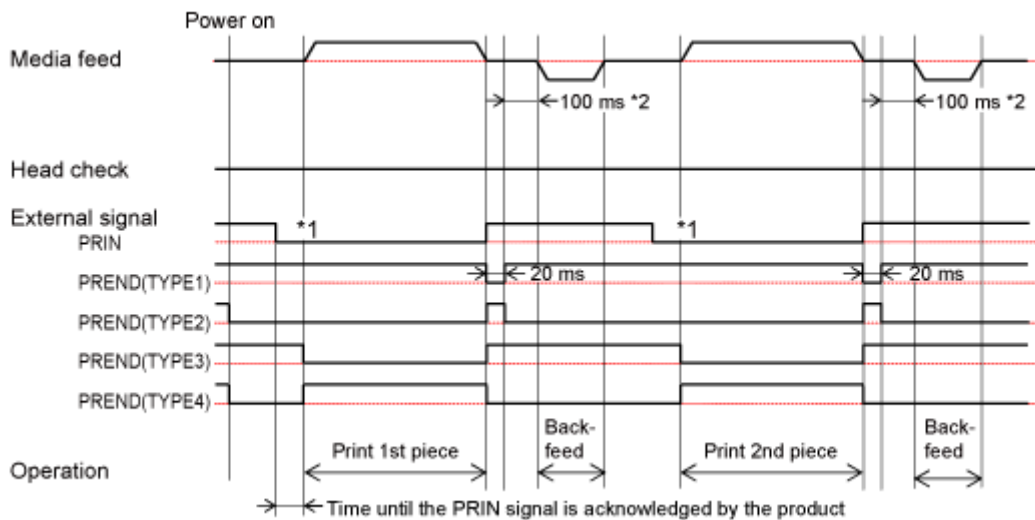

### Timing Chart (With Head Check)

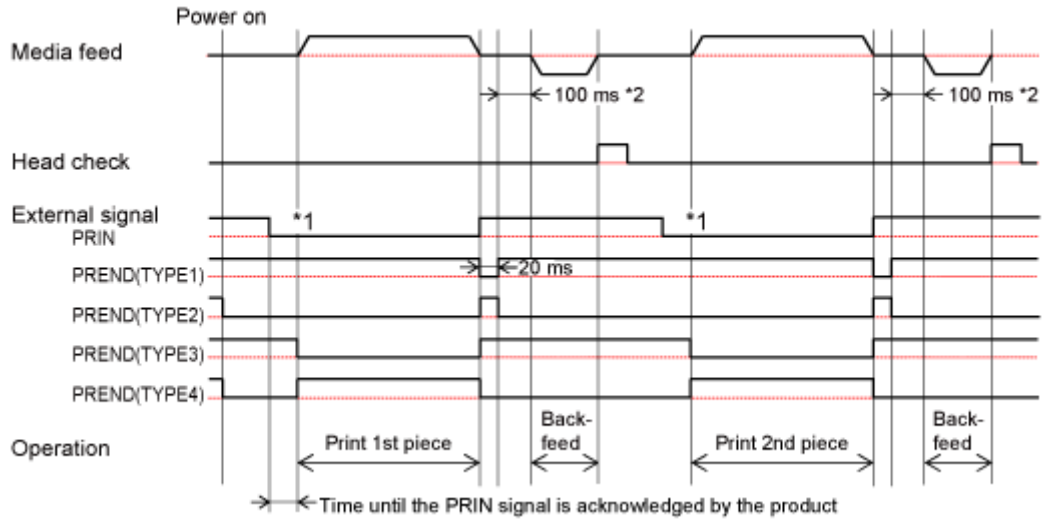

\*1 Keep the PRIN (Print Start) signal until the PREND (Print End) signal is outputted.

\*2 If you have selected [Enabled] for [Printing] > [Advanced] > [Printing Operations] > [Throughput Mode], then it is 7.5 ms.

## Dispenser Mode, Backfeed Before Printing, with Media Sensor Enabled, and with Pulse Input

### Operation

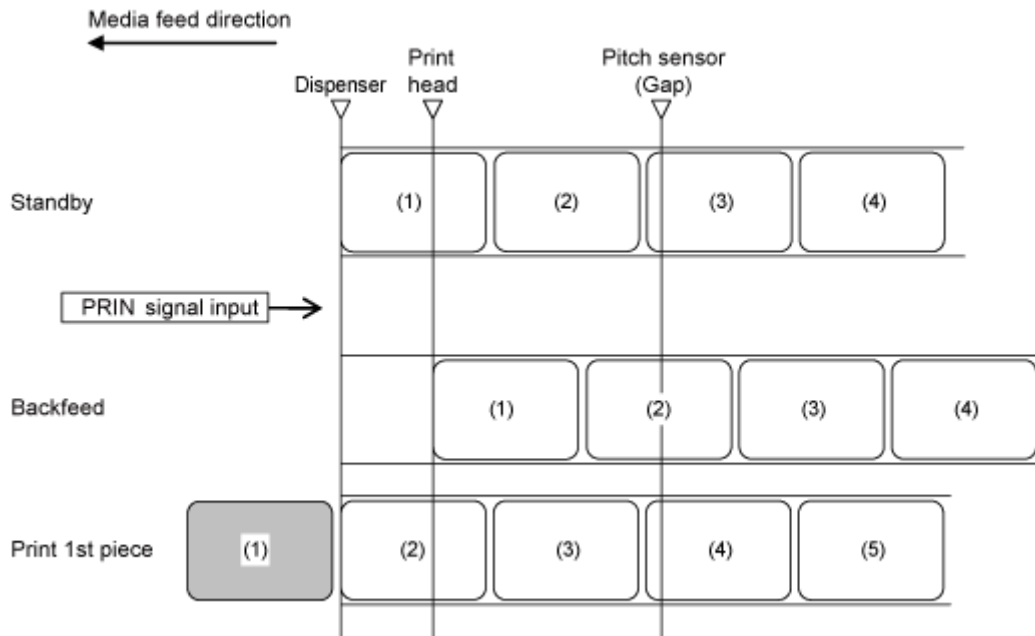

- The figure above shows the reference position when the Gap sensor is used.

### Timing Chart (Without Head Check)

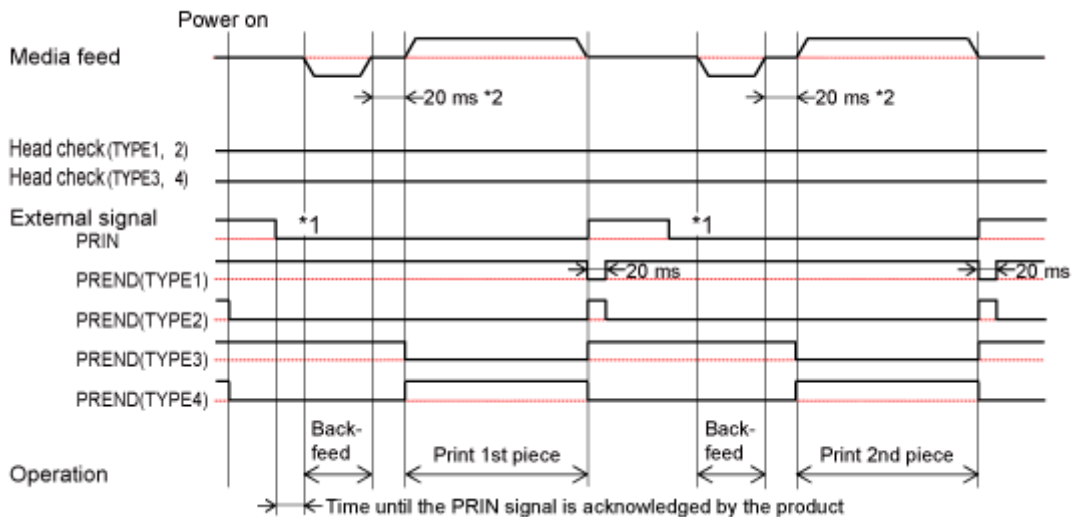



## Timing Chart (With Head Check)

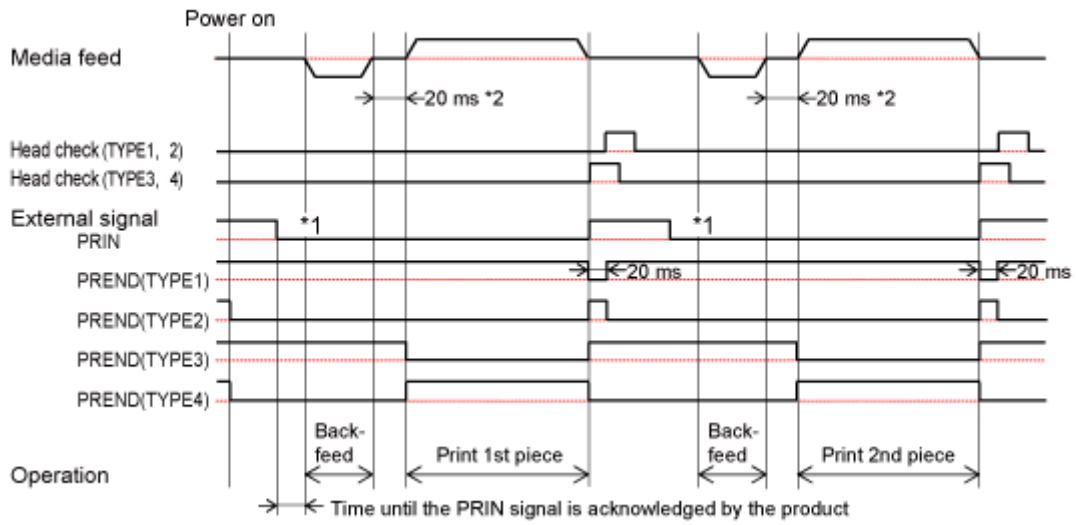

\*1 Keep the PRIN (Print Start) signal until the PREND (Print End) signal is outputted.

\*2 If you have selected [Enabled] for [Printing] > [Advanced] > [Printing Operations] > [Throughput Mode], then it is 7.5 ms.

## Dispenser Mode, Backfeed Before Printing, with Extend Backfeed Operation Function Enabled, with Media Sensor Enabled, and with Pulse Input

Operation that is enabled when [Printing] > [Advanced] > [Printing Operations] > [Extended Backfeed Operation] is enabled.

Print data is received, and at the stage that printing is possible, then backfeed is done and the product waits for input of the Print Start signal (PRIN).

### Operation

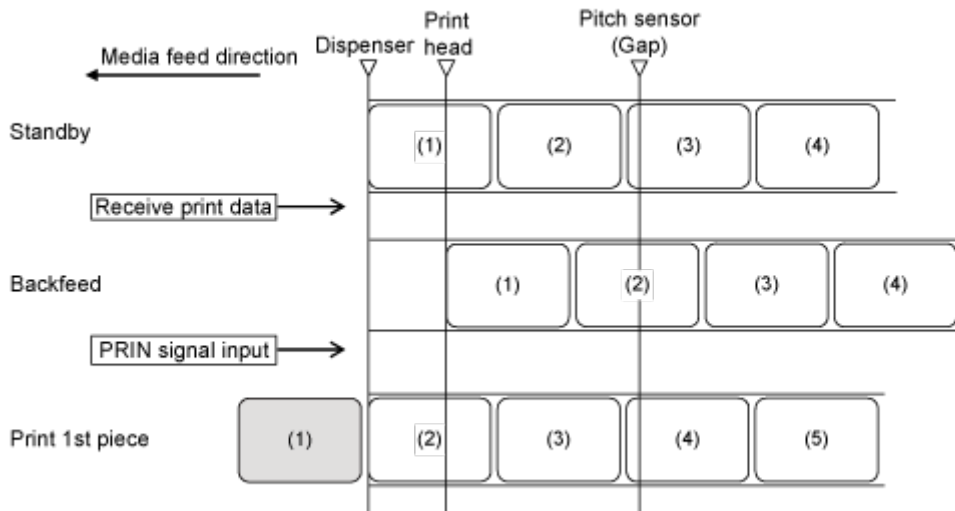

- The figure above shows the reference position when the Gap sensor is used.

### Timing Chart (Without Head Check)

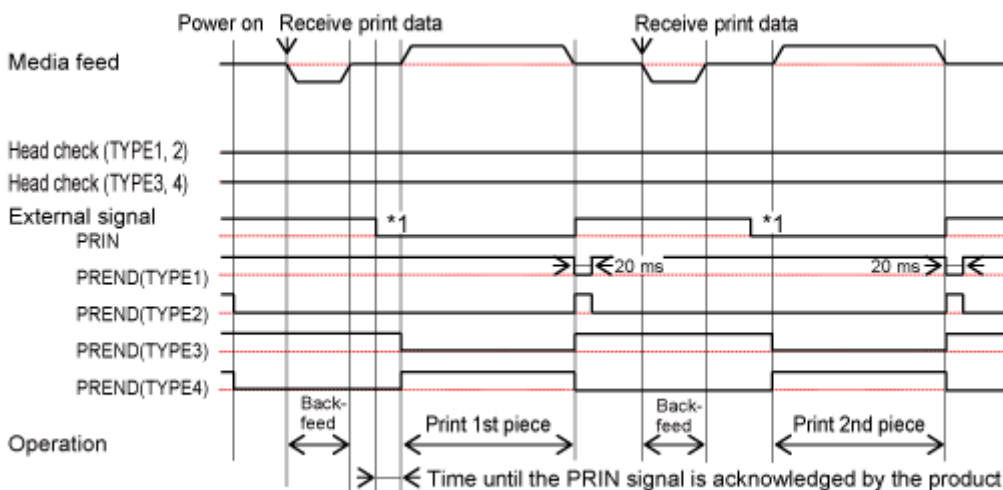

### Timing Chart (With Head Check)

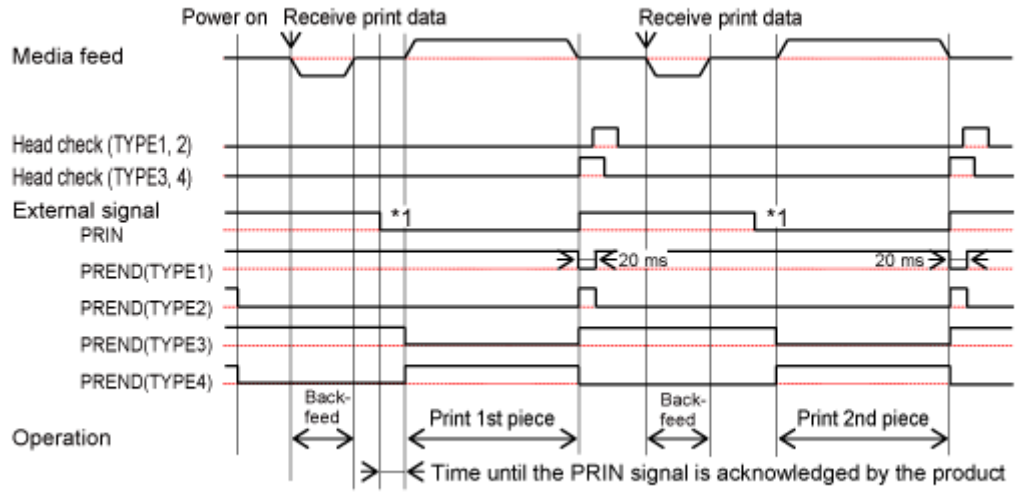

\*1 Keep the PRIN (Print Start) signal until the PREND (Print End) signal is outputted.

## Dispenser Mode, Backfeed After Printing with External Signal Input, with Media Sensor Enabled, and with Pulse Input

### Operation

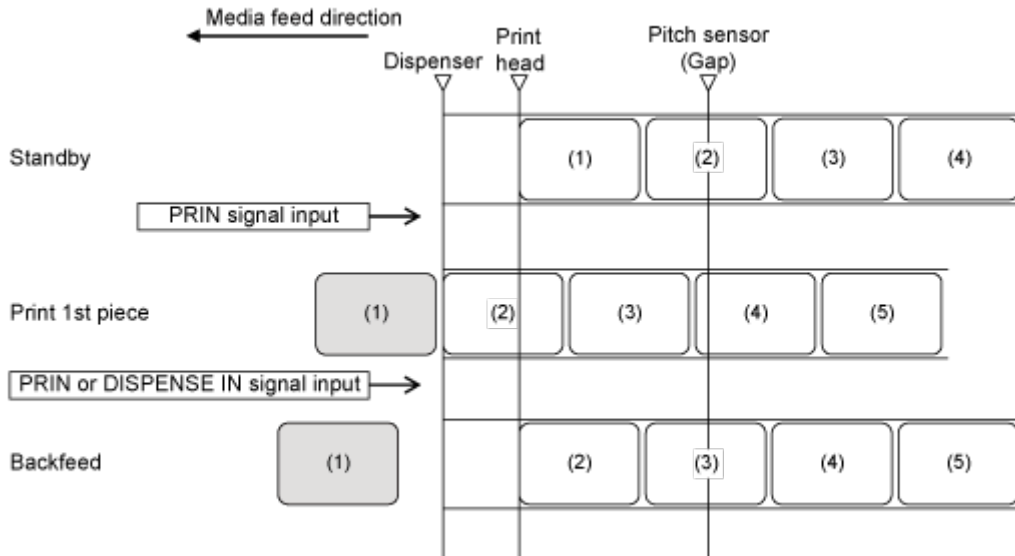

- The figure above shows the reference position when the Gap sensor is used.

### Timing Chart (Without Head Check)

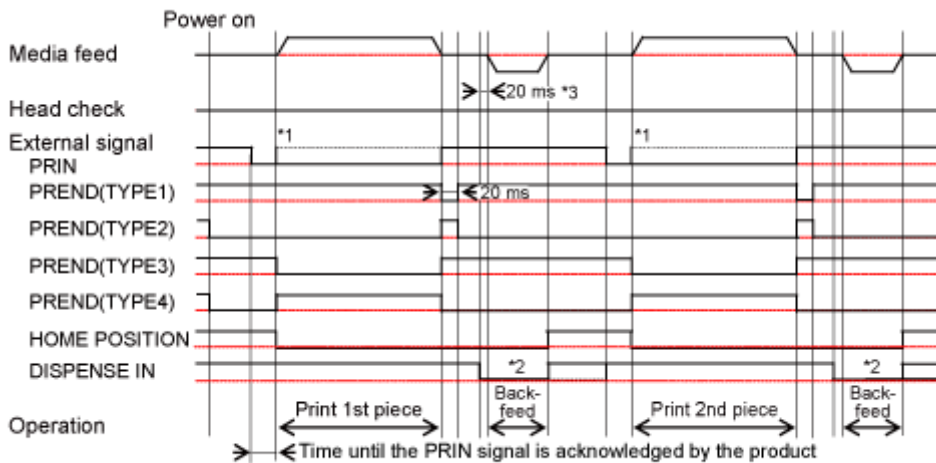

## Timing Chart (With Head Check)

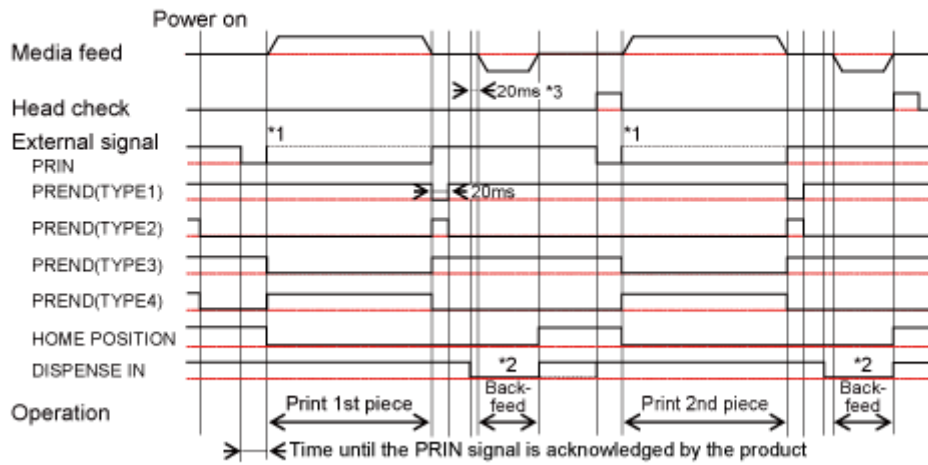

\*1 Keep the PRIN (Print Start) signal until the PREND (Print End) signal is outputted. And then, turn the PRIN (Print Start) signal off before the PREND (Print End) signal detects that printing has ended.

\*2 Keep the DISPENSE IN signal until the Home Position signal is output. And then, turn the DISPENSE IN signal off before the PRIN (Print Start) signal is input.

\*3 If you have selected [Enabled] for [Printing] > [Advanced] > [Printing Operations] > [Throughput Mode], then it is 7.5 ms.

## Operations in Dispense & Print Mode

### Dispense & Print Mode, Backfeed After Printing, with Media Sensor Enabled, and with Pulse Input

#### Operation

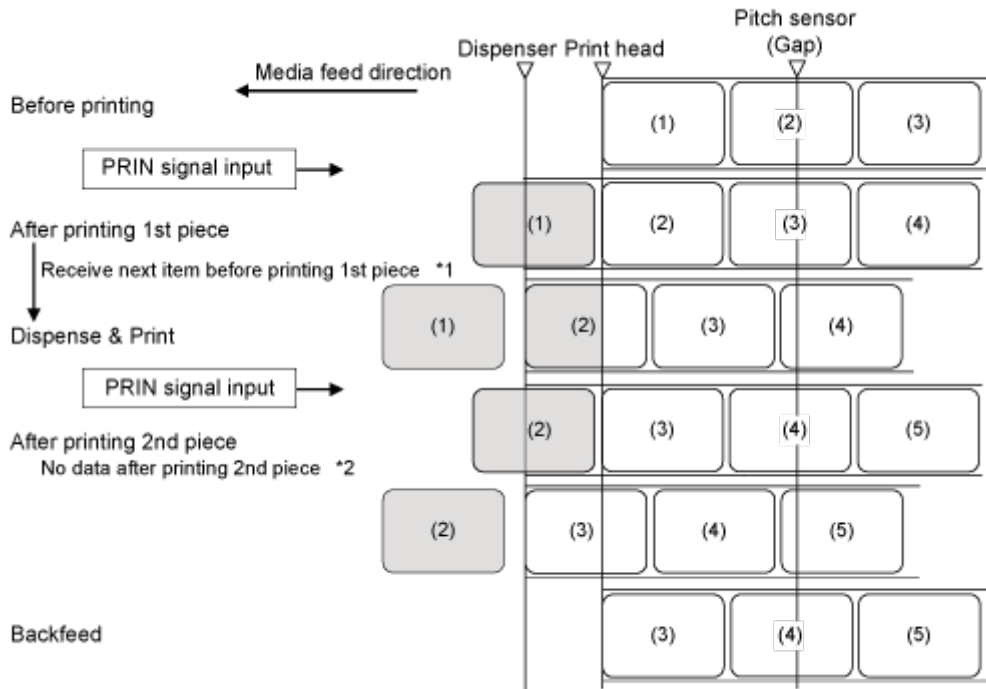

\*1 If the next data is received before printing finishes, then the next print operation is done and dispensing stops at the dispensing position.

\*2 If the next data is not completed before printing is finished, then blank media is fed and dispensing stops at the dispensing position.



- The figure above shows the reference position when the Gap sensor is used.

## Timing Chart (Without Head Check)

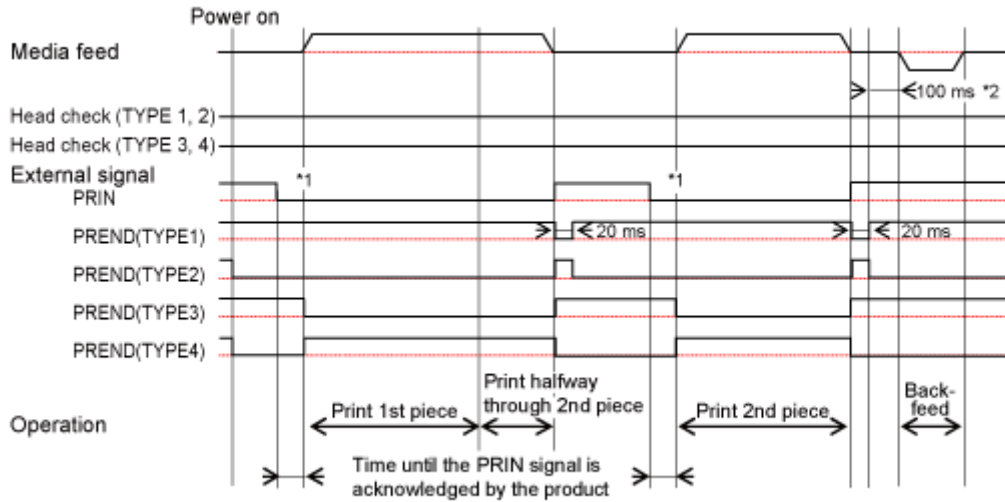

- If print data contains the RFID command, then printing stops temporarily after printing 1 label. In this case, the external signal input operations are the same as when head check is enabled.
- If you have selected [Enabled] in the [Printing] > [Advanced] > [Calendar Setting Mode] > [Calendar Reprint] menu or the [Interface] > [External I/O] > [EXT I/O Re-print] > [Enhanced Reprint] menu, then it is the operation of dispenser mode.

## Timing Chart (With Head Check)

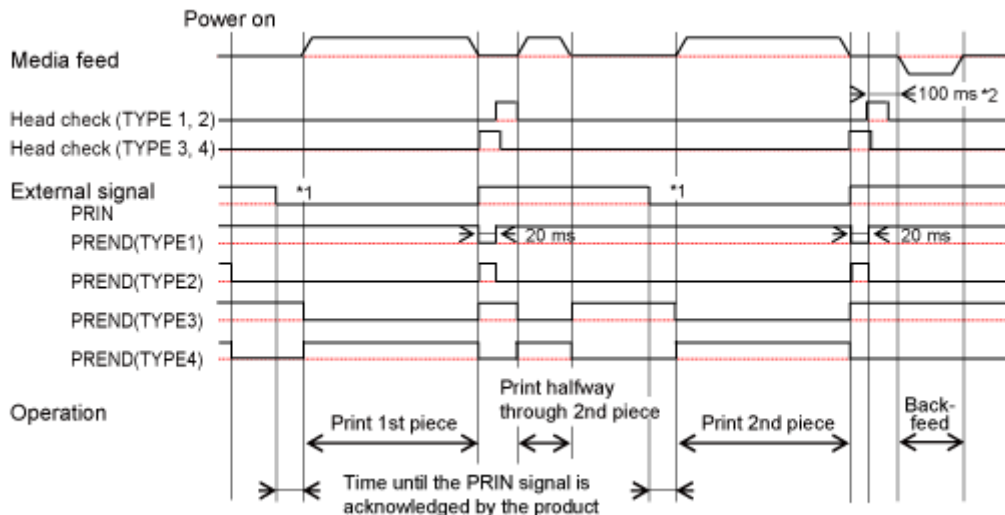

- It is recommended to use TYPE3 or TYPE4 PREND (Print End) signal.
- If you have selected [Enabled] in the [Interface] > [External I/O] > [EXT I/O Re-print] > [Enhanced Reprint] menu, then it is the operation of dispenser mode.

\*1 Keep the PRIN (Print Start) signal until the PREND (Print End) signal is outputted.

\*2 If you have selected [Enabled] for [Printing] > [Advanced] > [Printing Operations] > [Throughput Mode], then it is 7.5 ms.

## Dispense & Print Mode, Backfeed Before Printing, with Media Sensor Enabled, and with Pulse Input

### Operation

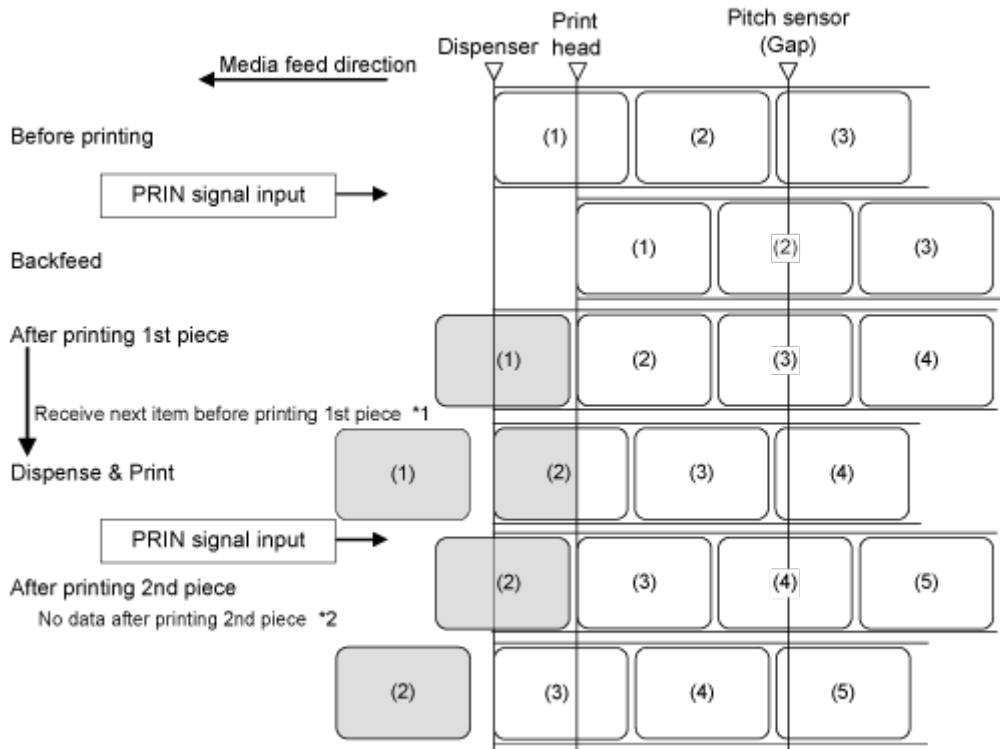

\*1 If the next data is received before printing finishes, then the next print operation is done and dispensing stops at the dispensing position.

\*2 If the next data is not completed before printing is finished, then blank media is fed and dispensing stops at the dispensing position.



- The figure above shows the reference position when the Gap sensor is used.



## Timing Chart (Without Head Check)

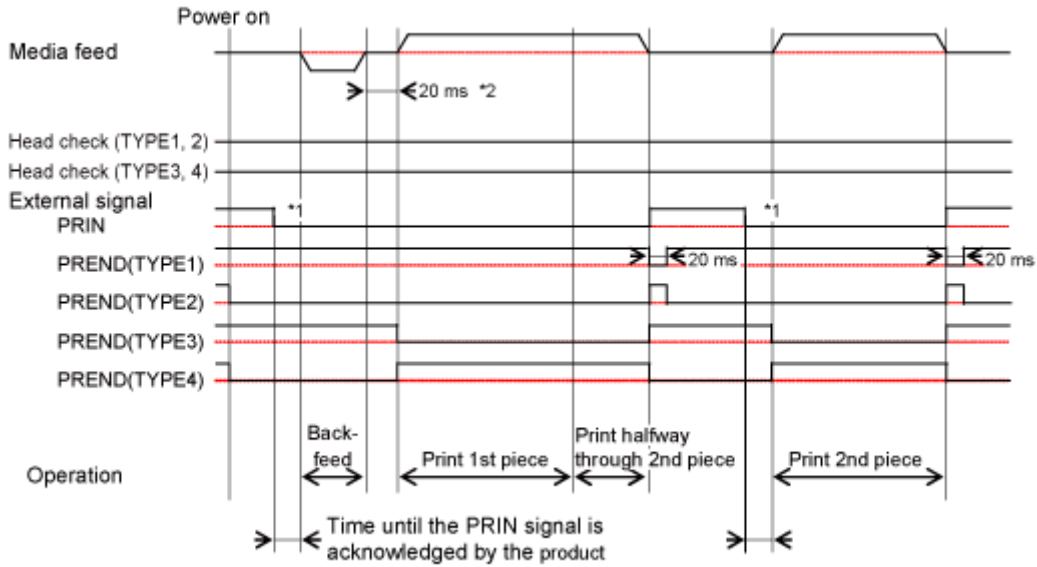

- If print data contains the RFID command, then printing stops temporarily after printing 1 label. In this case, the external signal input operations are the same as when head check is enabled.
- If you have selected [Enabled] in the [Printing] > [Advanced] > [Calendar Setting Mode] > [Calendar Reprint] menu or the [Interface] > [External I/O] > [EXT I/O Re-print] > [Enhanced Reprint] menu, then it is the operation of dispenser mode.

## Timing Chart (With Head Check)

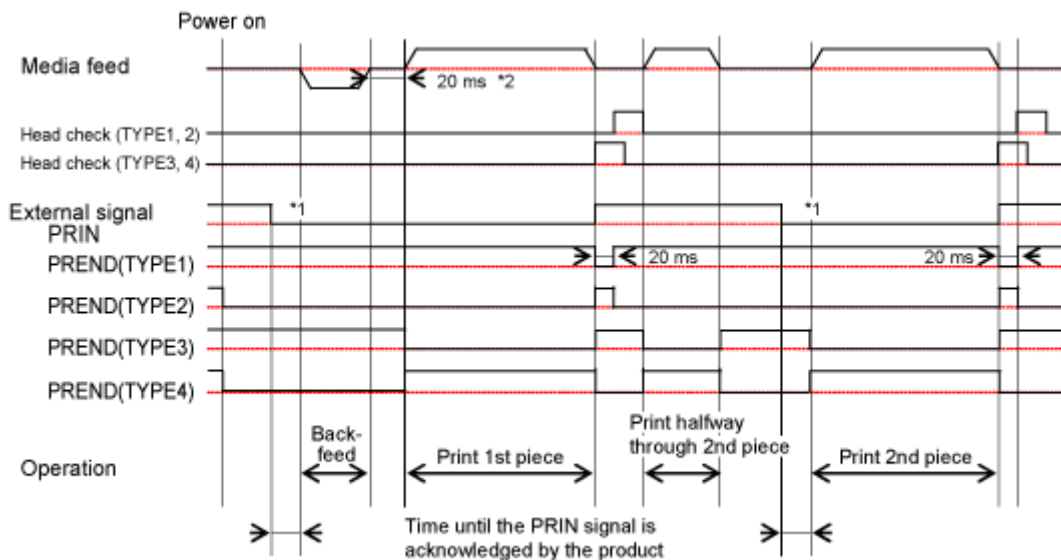

- It is recommended to use TYPE3 or TYPE4 PREND (Print End) signal.
- If you have selected [Enabled] in the [Interface] > [External I/O] > [EXT I/O Re-print] > [Enhanced Reprint] menu, then it is the operation of dispenser mode.

\*1 Keep the PRIN (Print Start) signal until the PREND (Print End) signal is outputted.

\*2 If you have selected [Enabled] for [Printing] > [Advanced] > [Printing Operations] > [Throughput Mode], then it is 7.5 ms.

## Operations in Linerless Mode

### Linerless Mode, Backfeed Before Printing, with Media Sensor Disabled, and with Pulse Input

#### Operation

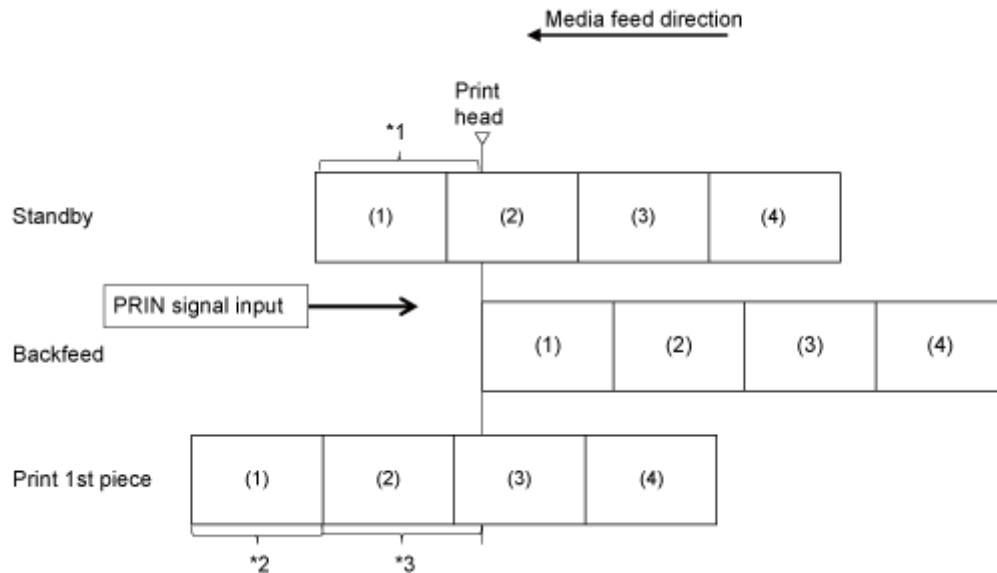

\*1 Feeds distance set for [Backfeed Offset]

\*2 Actual print size in vertical direction

\*3 Feeds total of distance set for [Feed Offset] and size specified by the End Position <EP> command



- The spaces between each layout varies depending on the print speed.  
In the figure above, as you set the print speed faster, the space between the first and second print becomes wider.
- You can set the [Feed Offset] and [Backfeed Offset] in the [Printing] > [Advanced] menu.

### Timing Chart (Without Head Check)

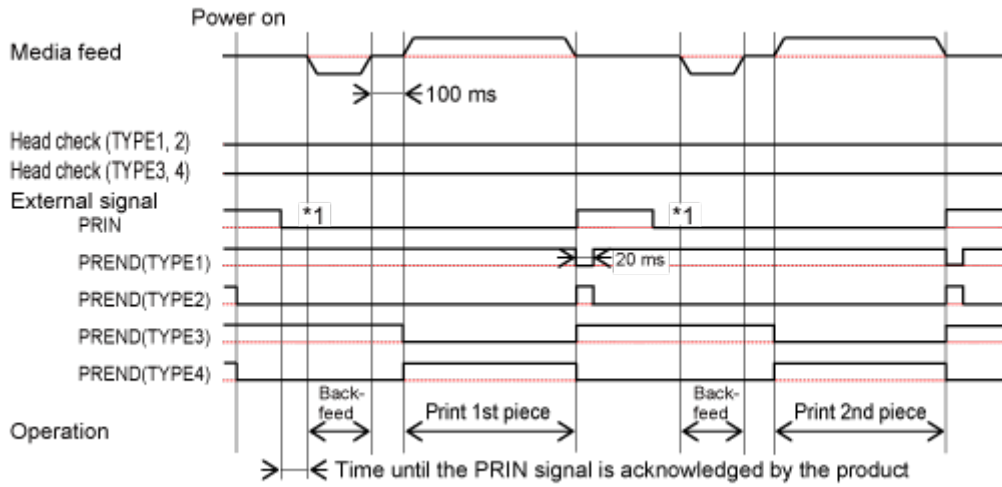

### Timing Chart (With Head Check)

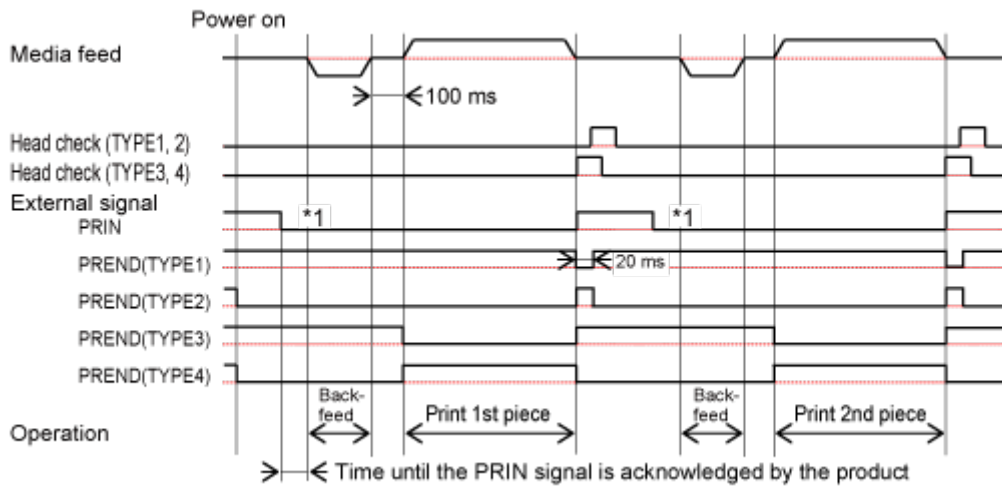

\*1 Keep the PRIN (Print Start) signal until the PREND (Print End) signal is outputted.



- Do feeding while pressing the  button in the Offline mode. However, the PREND (Print End) signal will not change.

## Operations for RFID Write (S84NX Only)

### RFID Write with Continuous Mode (Tag Offset = 0) (S84NX Only)

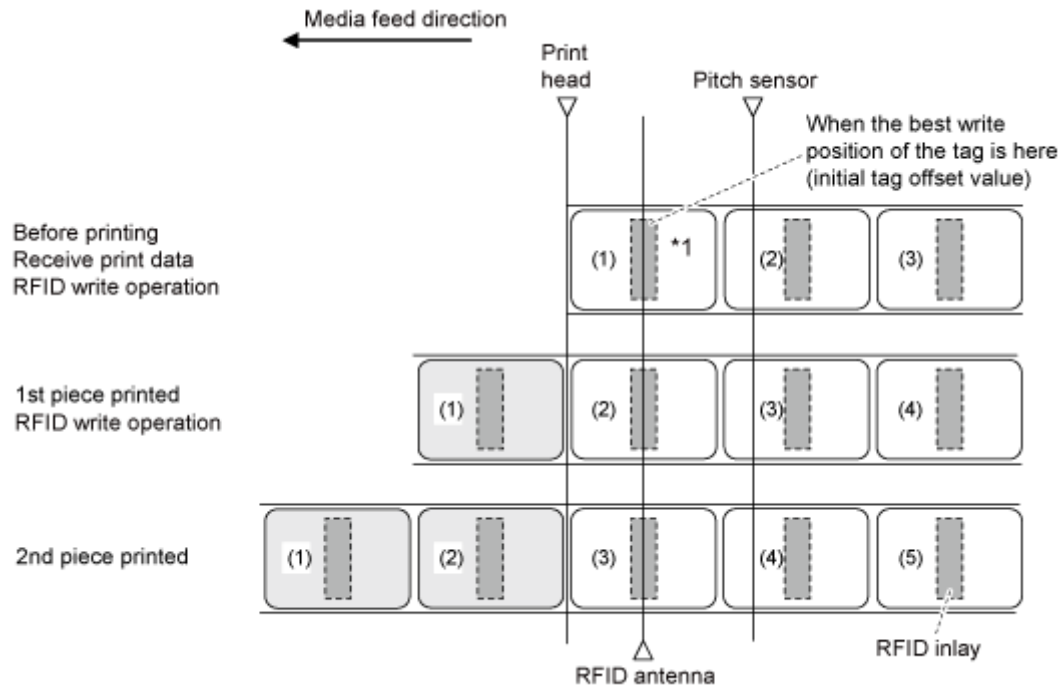

\*1 The EPC code write <IP0> command writes the data at this inlay position. The EPC code read, RFID read [DC2]PJ, UID/EPC/IDm print <TU>, and UID/EPC/IDm return <RU> commands acquire the information at this inlay position.

## RFID Write with Continuous Mode (Tag Offset > 0) (S84NX Only)

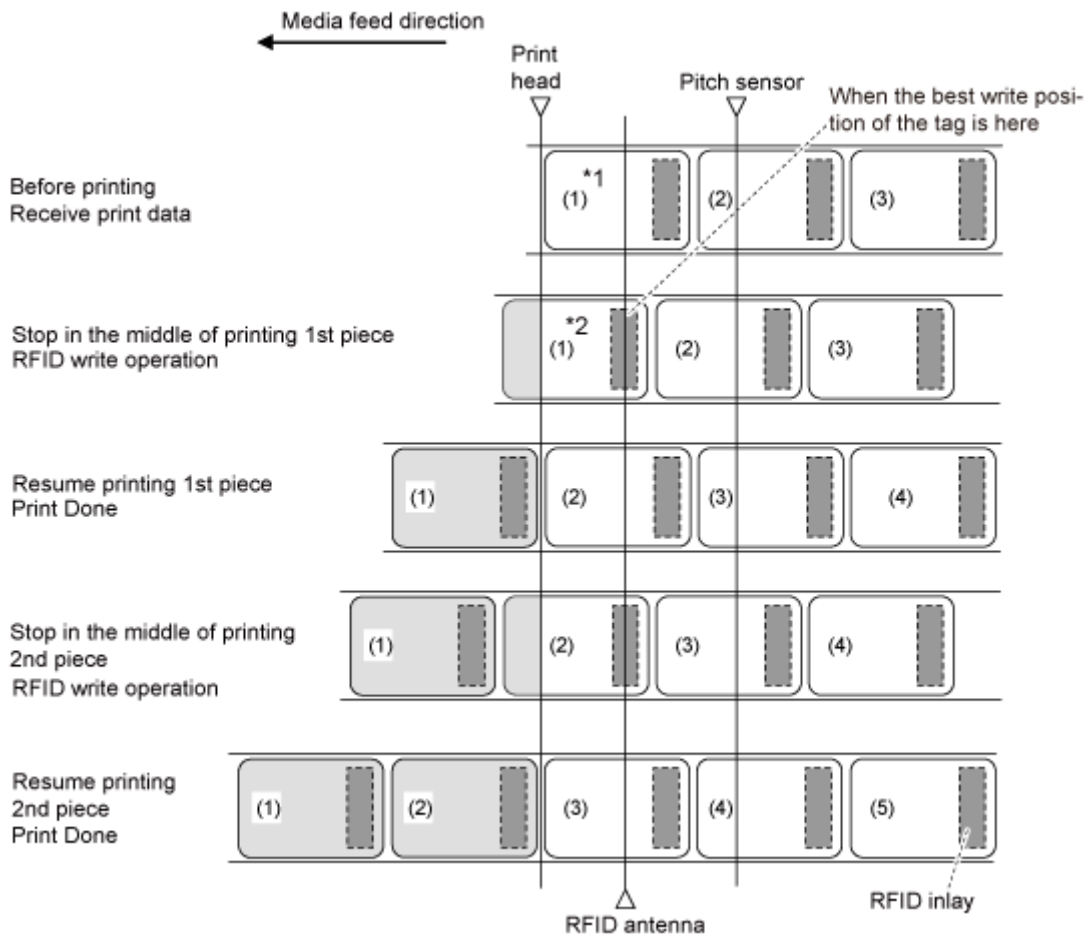

\*1 Because the EPC code read, RFID read [DC2]PJ and UID/EPC/IDm print <TU> commands acquire the information at this inlay position, do not use them.

\*2 The EPC code write <IP0> command writes the data at this inlay position. The EPC code read and UID/EPC/IDm return <RU> commands acquire the information at this inlay position.

## RFID Write with Continuous Mode (Tag Offset < 0) (S84NX Only)

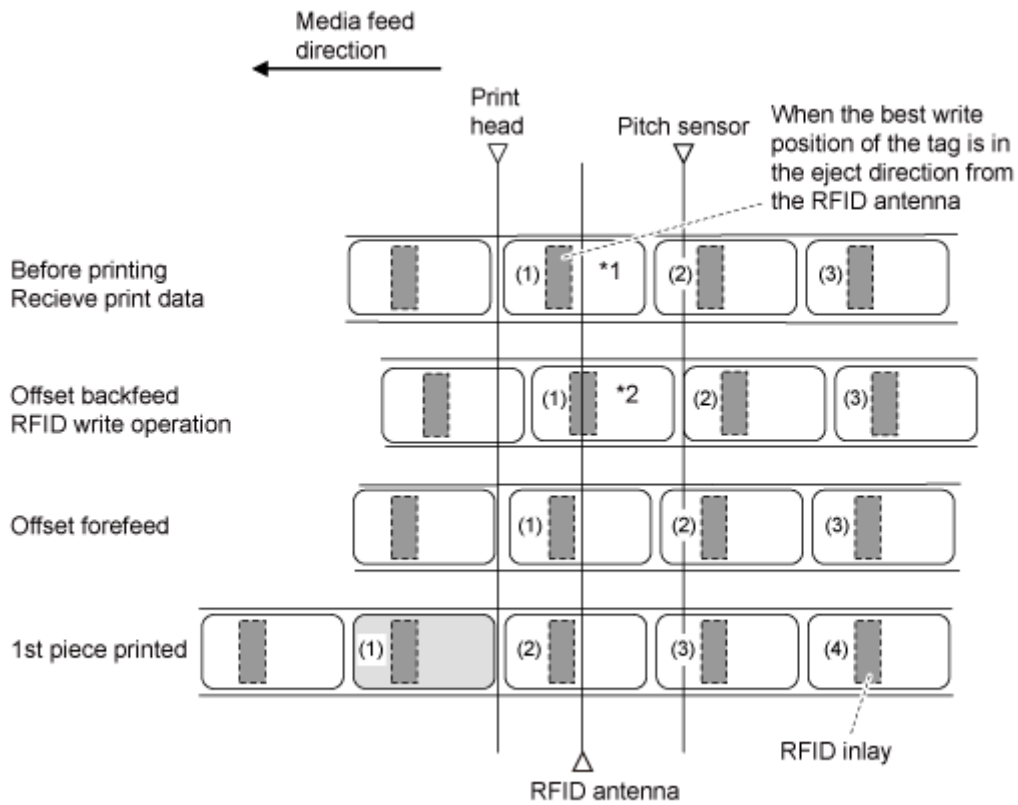

\*1 Because the EPC code read and RFID read [DC2]PJ commands acquire the information at this inlay position, do not use them.

\*2 The EPC code write <IP0> command writes the data at this inlay position. The EPC code read, UID/EPC/IDm print <TU>, and UID/EPC/IDm return <RU> commands acquire the information at this inlay position.

## RFID Write with Dispenser Mode and Backfeed After Printing (Tag Offset = 0) (S84NX Only)

When dispenser mode with backfeed after printing is selected, the tag backfeeds after the tag is removed and stops at the print head position.

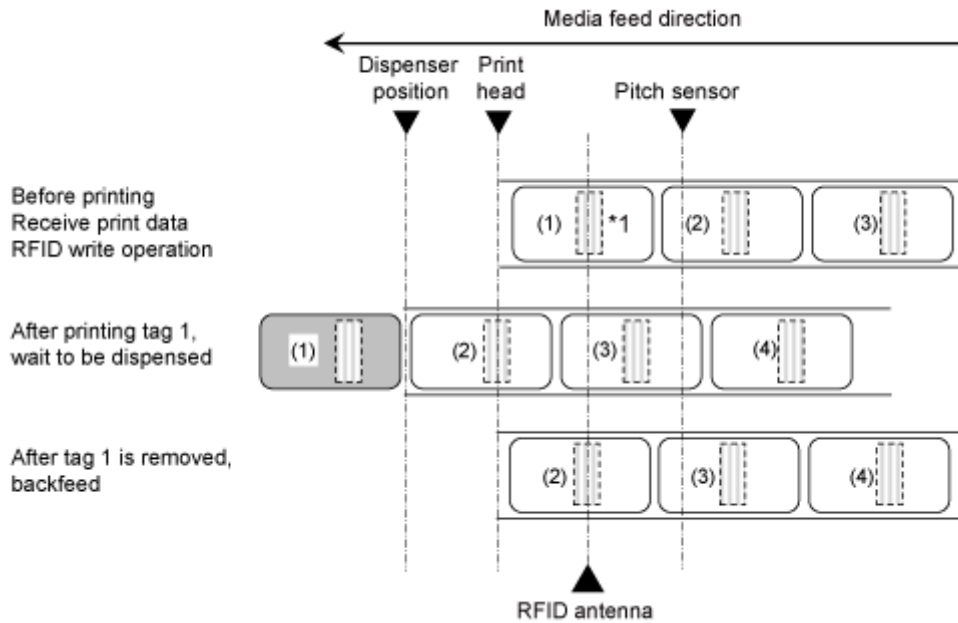

\*1 The EPC code write <IP0> command writes the data at this inlay position. The EPC code read, RFID read [DC2]PJ, UID/EPC/IDm print <TU>, and UID/EPC/IDm return <RU> commands acquire the information at this inlay position.



## RFID Write with Dispenser Mode and Backfeed After Printing (Tag Offset > 0) (S84NX Only)

When dispenser mode with backfeed after printing is selected, the tag backfeeds after dispensing and the tag is removed, and stops at the print head position, and then the next item is analyzed and printing is executed.

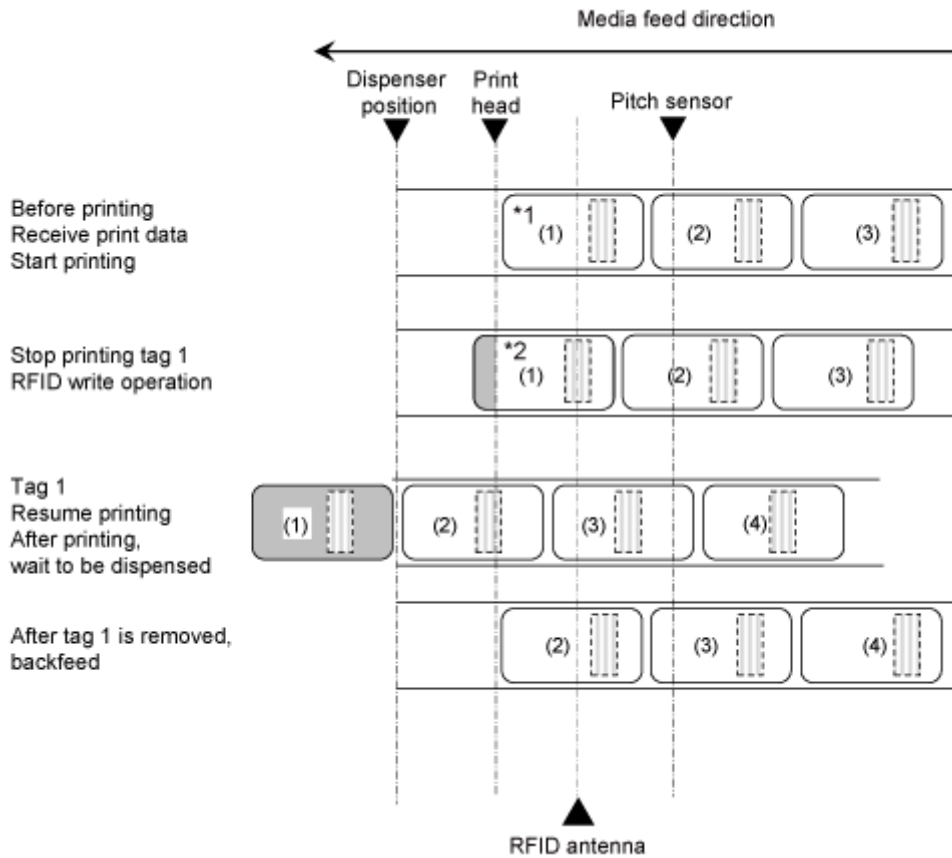

\*1 Because the EPC code read, RFID read [DC2]PJ, UID/EPC/IDm print <TU>, and UID/EPC/IDm return <RU> commands acquire the information at this inlay position, do not use them if the Tag Offset is set to other than an initial value.

\*2 The EPC code write <IP0> command writes the data at this inlay position. The EPC code read, and UID/EPC/IDm return <RU> commands acquire the information at this inlay position.

## RFID Write with Dispenser Mode and Backfeed Before Printing (Tag Offset = 0) (S84NX Only)

When dispenser mode with backfeed before printing is selected, the tag backfeeds before printing, and stops at the dispensing position after printing.

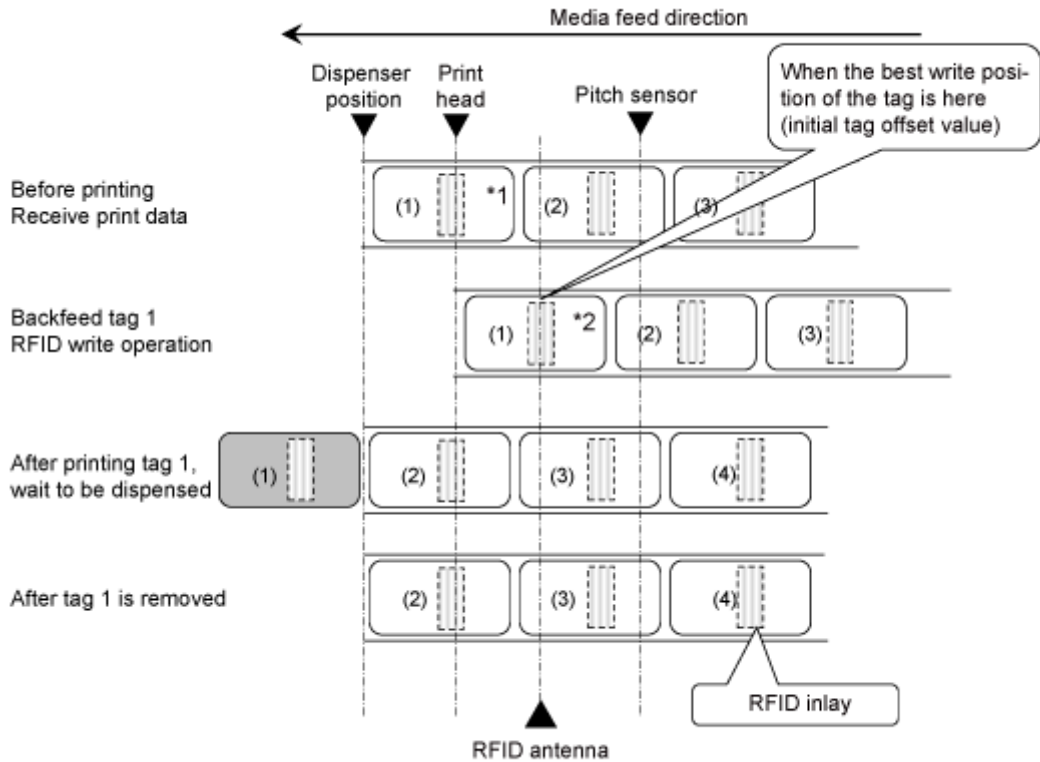

\*1 Because the EPC code read and RFID read [DC2]PJ commands acquire the information at this inlay position, do not use them.

\*2 The EPC code write <IP0> command writes the data at this inlay position. The EPC code read, UID/EPC/IDm print <TU>, and UID/EPC/IDm return <RU> commands acquire the information at this inlay position.

## RFID Write with Dispenser Mode and Backfeed Before Printing (Tag Offset > 0) (S84NX Only)

When dispenser mode with backfeed before printing is selected, the tag backfeeds before printing, and stops at the dispensing position after printing.

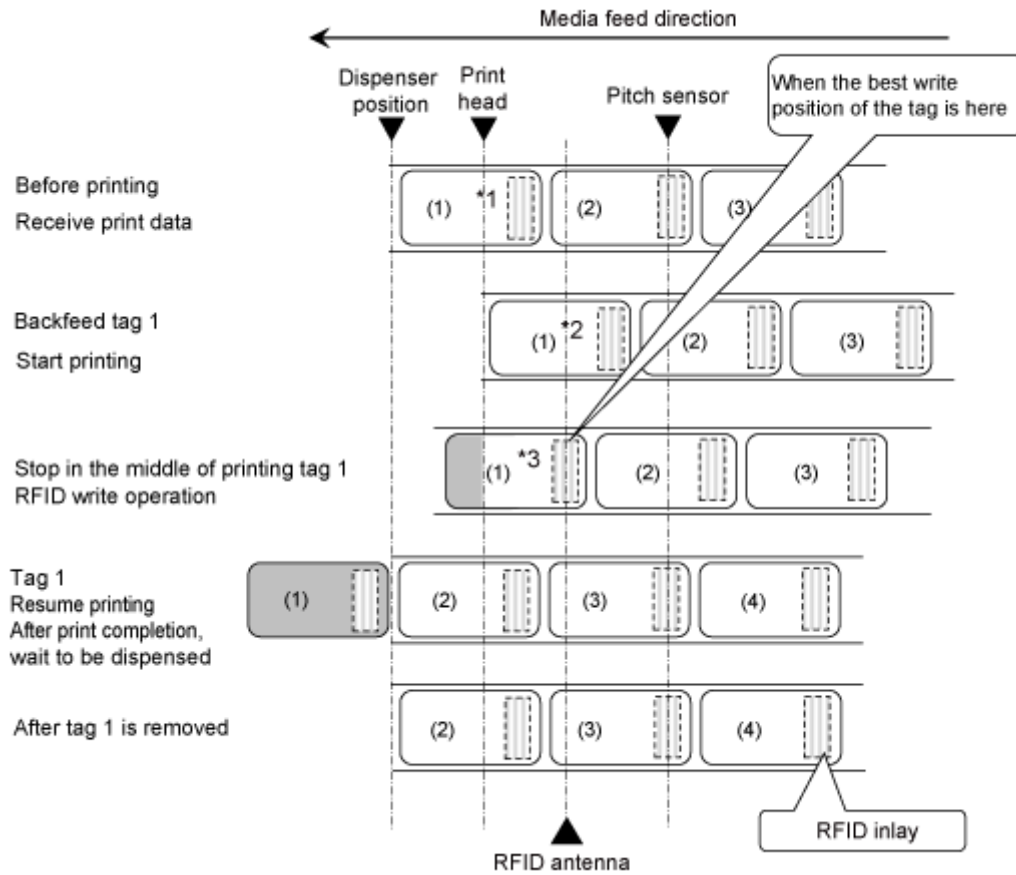

\*1 Because the EPC code read and RFID read [DC2]PJ commands acquire the information at this inlay position, do not use them.

\*2 Because the EPC code read and UID/EPC/IDm print <TU> commands acquire the information at this inlay position, do not use them if the Tag Offset is set to other than an initial value.

\*3 The EPC code write <IP0> command writes the data at this inlay position. The EPC code read, and UID/EPC/IDm return <RU> commands acquire the information at this inlay position.

## RFID Write with Dispense & Print Mode (S84NX Only)

When the dispense & print mode is selected, RFID encoding is performed before printing while stopping at the print head position.

RFID tag offset cannot be used in the dispense & print mode. The setting value will be ignored even if tag offset is set. Also, this mode cannot be used for mixed issuance of RFID items and items that do not contain RFID commands.

Also, the RFID tag error print in the dispense & print mode is the same as the error print in the continuous or dispenser mode.

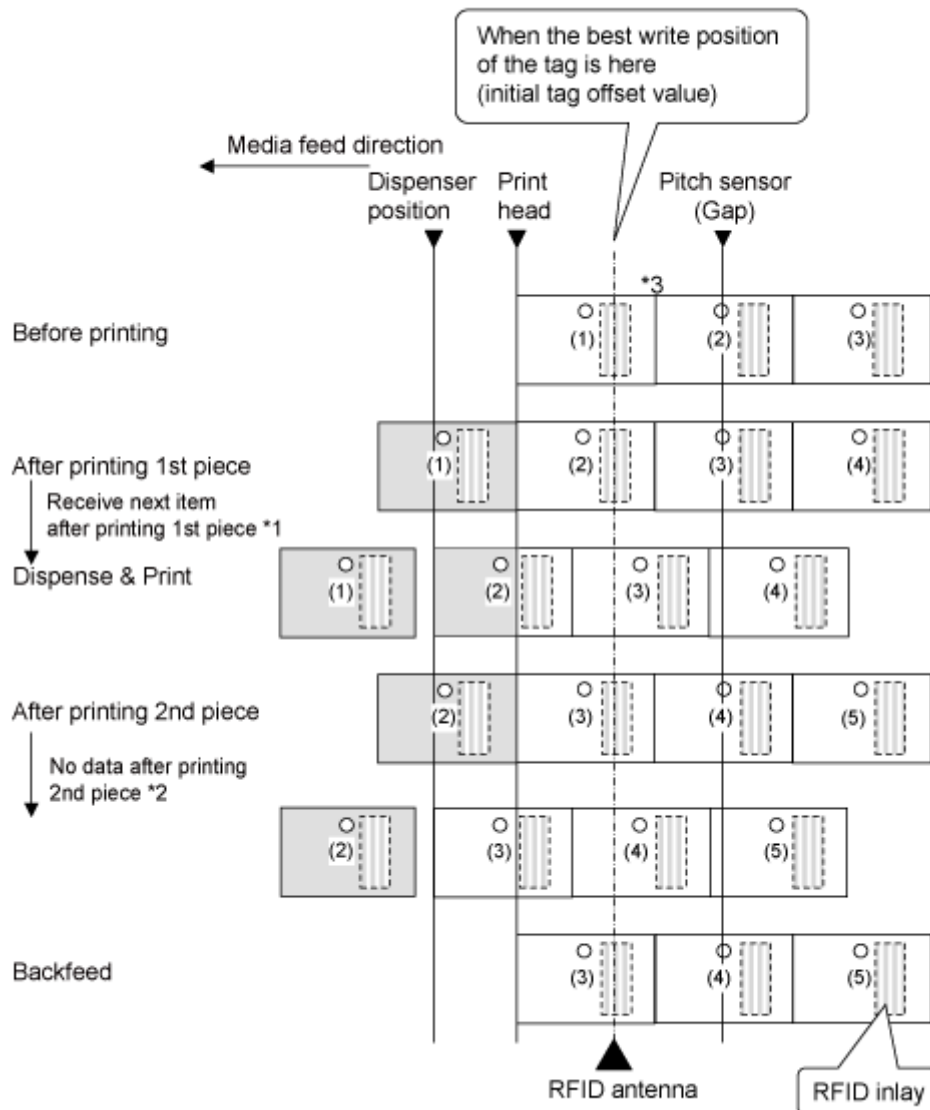

\*1 If the next data is received after printing finishes, then the next print operation is done and dispensing stops at the dispensing position.

\*2 If the next data is not completed before printing is finished, then blank media is fed and dispensing stops at the dispensing position.

\*3 The EPC code write <IP0> command writes the data at this inlay position. The RFID read [DC2]PJ, printing tag data <TU>, and EPC/TID return <RU> commands acquire the information at this inlay position.

## Operations When the Barcode Check Function Is Enabled

### Continuous Mode When the Barcode Check Function Is Enabled

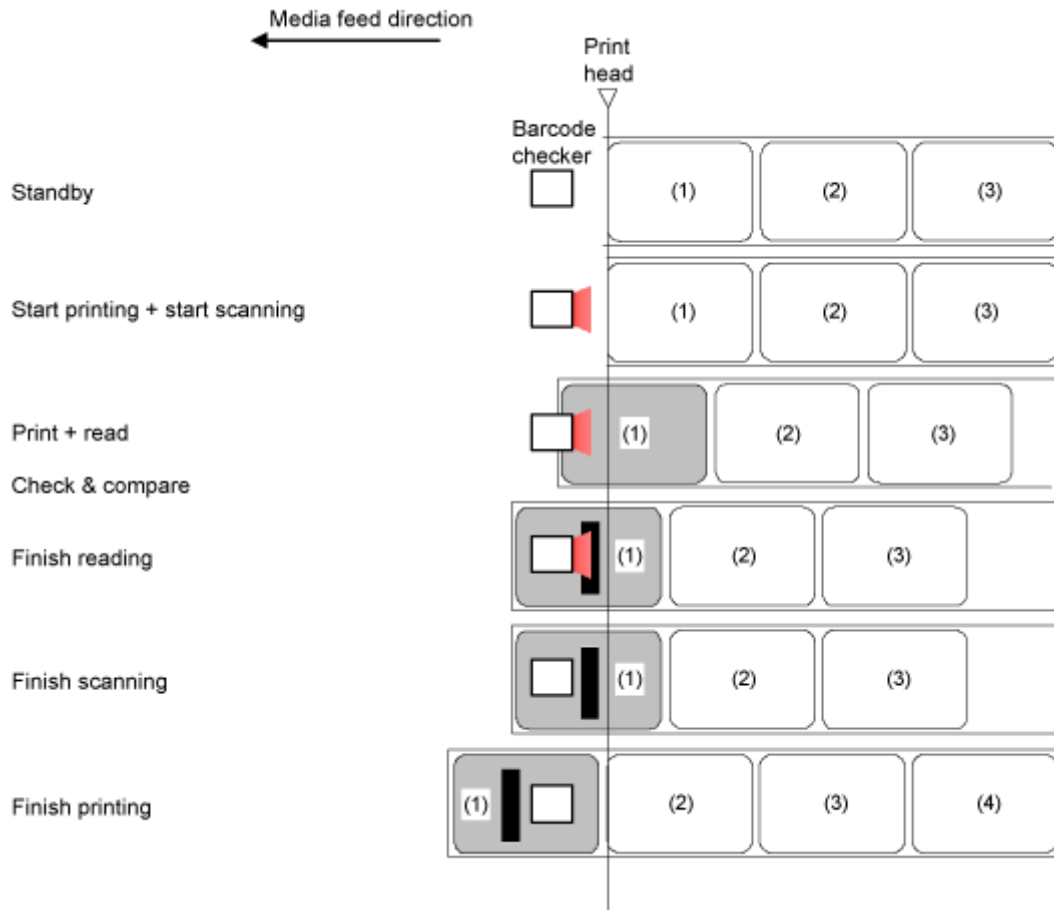

## Adjusting the Base Reference Point

### About the Base Reference Point

The base reference point is the point at which one determines the print position and stop/dispensing position.

The base reference point differs depending on the operation mode or media sensor you use.

#### Continuous Mode

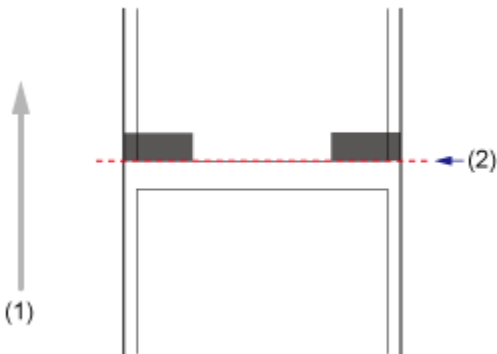
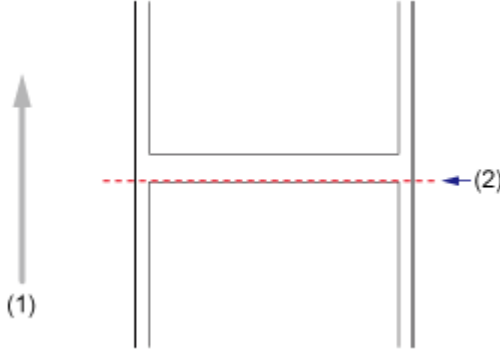
I-mark Label	Gap Label
 <p>(1) Feed direction (2) Print and stop position</p>	 <p>(1) Feed direction (2) Print and stop position</p>

#### Dispenser Mode/Dispense & Print Mode

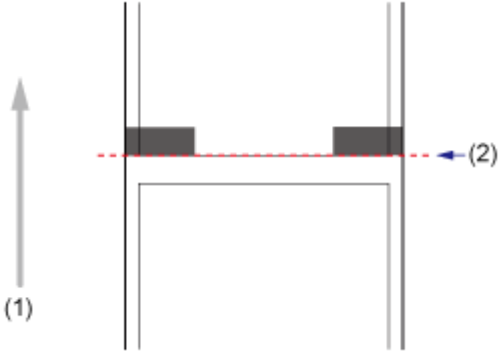
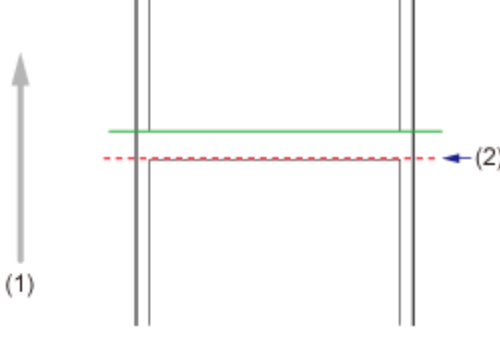
I-mark Label	Gap Label
 <p>(1) Feed direction (2) Print and dispensing position</p>	 <p>(1) Feed direction (2) Print and dispensing position</p>

## Adjusting the Print Position

Set the [Pitch] in the [Printing] > [Advanced] > [Adjustments] menu to adjust the print position.

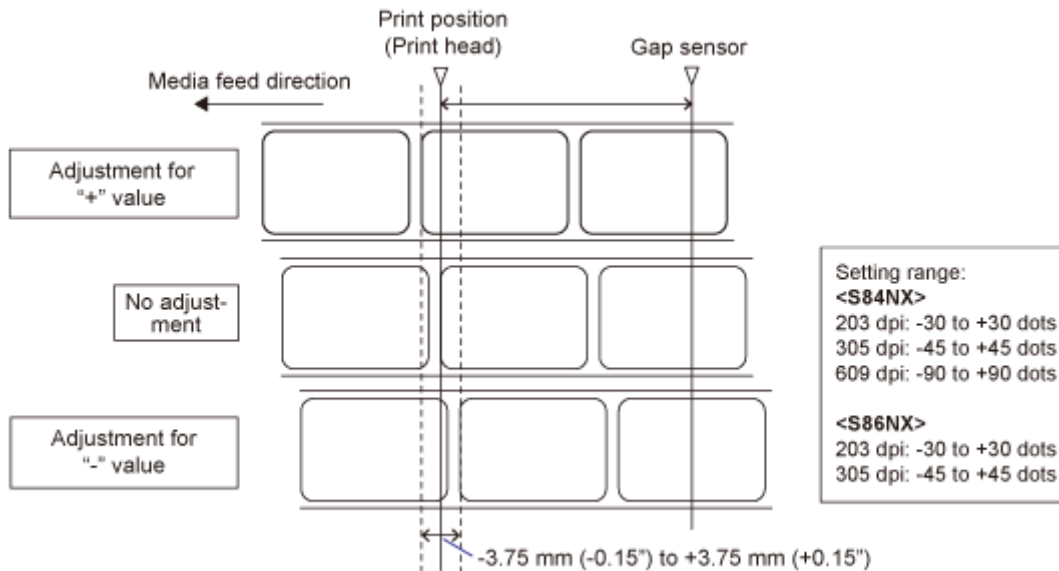

- The above reference position (print position) is the stop position when the media sensor type is set to Gap.
- You can adjust the print position during printing by registering the [Adjustments] menu to the [Shortcut] menu in advance.

- When the product is in Online mode, press the  button on the operator panel to change to Offline mode.



- Press the  button to show the [Settings] menu.



- Input the password if it is enabled.

3. Select [Printing] using the ◀/▶ buttons, and then press the ← button.

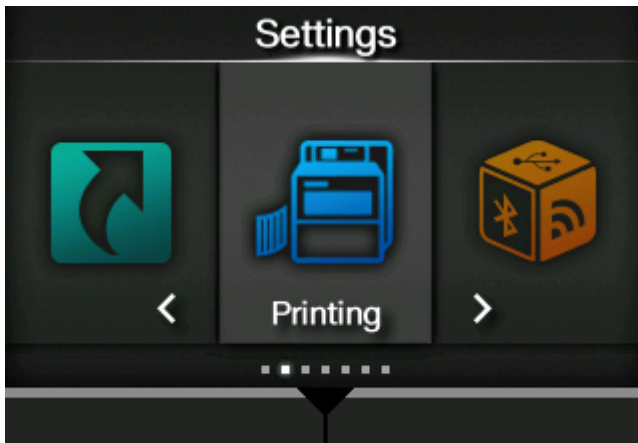

4. Select the [Advanced] > [Adjustments] > [Pitch] menu using the ▲/▼ buttons, and then press the ← button.

The [Pitch] screen appears.



5. Change the setting value. Press the ◀/▶/▲/▼ buttons to select a number and then press the ← button to enter the number to the text box.

The setting range is as follows:

Resolution	S84NX	S86NX
203 dpi (1 dot = 0.125 mm (0.0049"))	-30 to +30 dots	-30 to +30 dots
305 dpi (1 dot = 0.083 mm (0.0033"))	-45 to +45 dots	-45 to +45 dots
609 dpi	-90 to +90 dots	-



Resolution	S84NX	S86NX
(1 dot = 0.042 mm (0.0017"))		



- Do not allow the distance between [Pitch] and [Offset] after adjustments to exceed the size of 1 label (including liner).

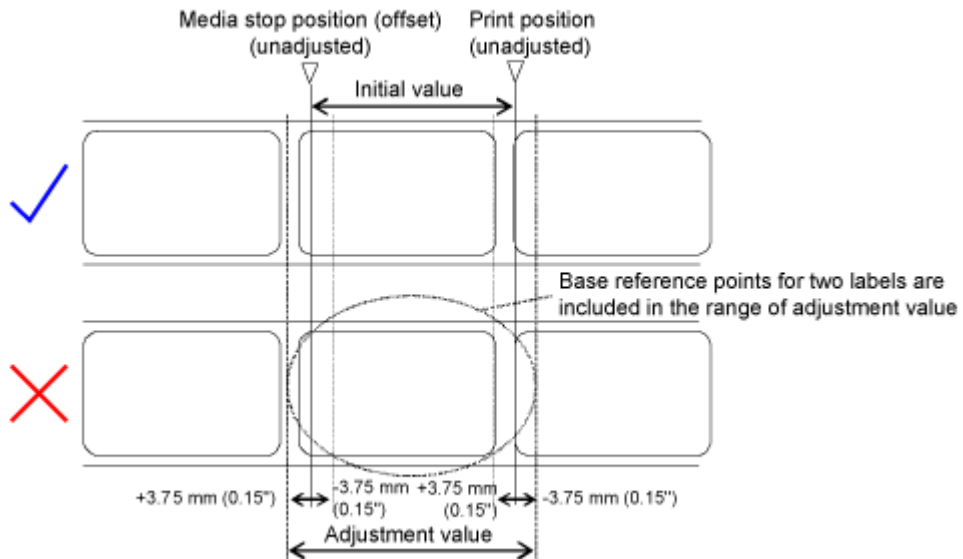

- You can change the units to dots, " (inches), or mm in the [System] > [Regional] > [Unit] menu.

- Press the button to save the setting value.
- Press the button to change to Offline mode.
- Press the button again to change to Online mode.

You can print to check the adjusted print position.

## Adjusting the Dispenser Stop Position

Set the [Offset] in the [Printing] > [Advanced] > [Adjustments] menu to adjust the dispenser stop position.

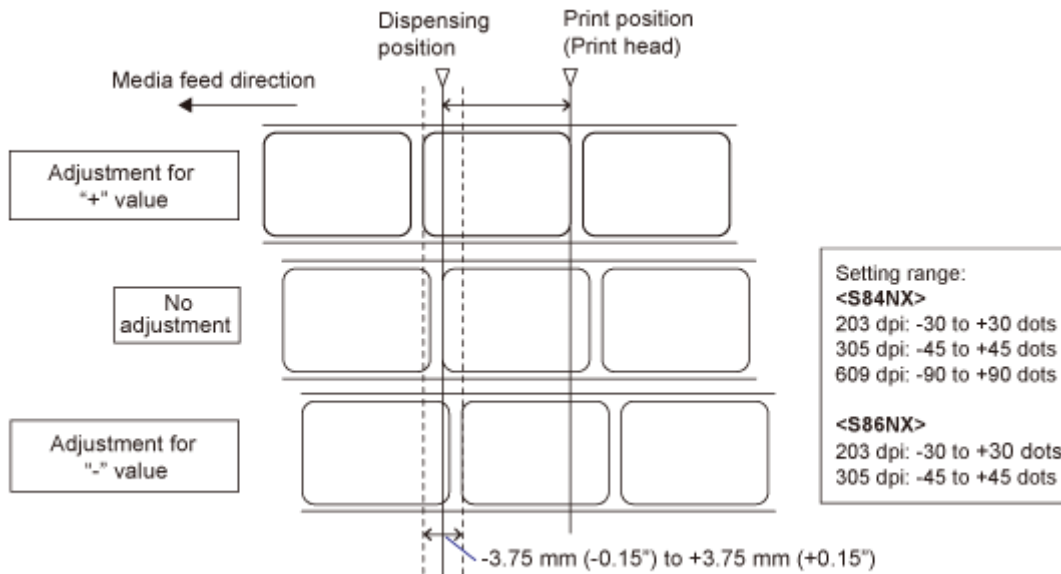

- The above dispenser stop position indicates the stop position when the media sensor type is set to Gap.
- You can adjust the dispenser stop position during printing by registering the [Adjustments] menu to the [Shortcut] menu in advance.

1. When the product is in Online mode, press the  button on the operator panel to change to Offline mode.



2. Press the  button to show the [Settings] menu.



- Input the password if it is enabled.

3. Select [Printing] using the ◀/▶ buttons, and then press the ⬅ button.

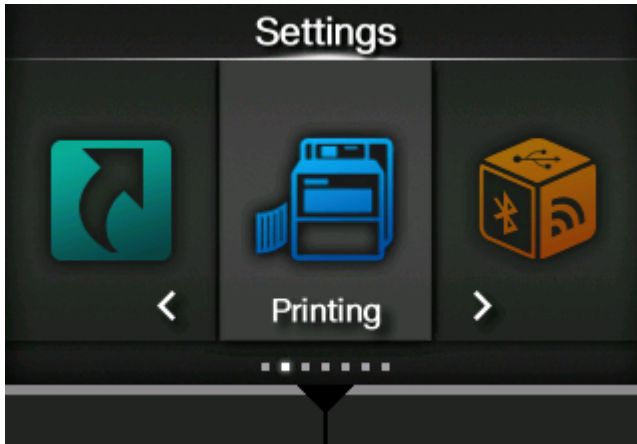

4. Select the [Advanced] > [Adjustments] > [Offset] menu using the ▲/▼ buttons, and then press the ⬅ button.

The [Offset] screen appears.



5. Change the setting value. Press the ◀/▶/▲/▼ buttons to select a number and then press the ⬅ button to enter the number to the text box.

The setting range is as follows:

Resolution	S84NX	S86NX
203 dpi (1 dot = 0.125 mm (0.0049"))	-30 to +30 dots	-30 to +30 dots
305 dpi (1 dot = 0.083 mm (0.0033"))	-45 to +45 dots	-45 to +45 dots

Resolution	S84NX	S86NX
609 dpi (1 dot = 0.042 mm (0.0017"))	-90 to +90 dots	-



- Do not allow the distance between [Pitch] and [Offset] after adjustments to exceed the size of 1 label (including liner).

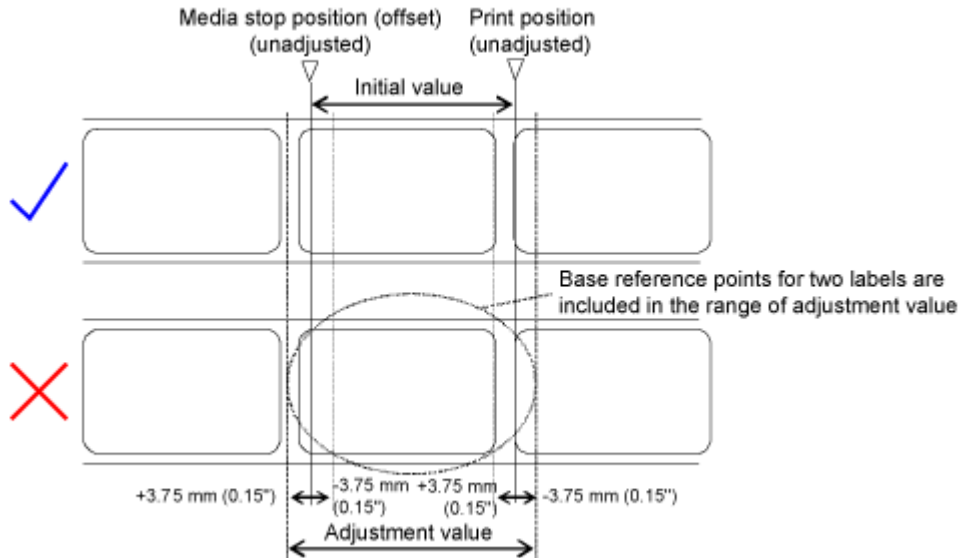

- You can change the units to dots, " (inches), or mm in the [System] > [Regional] > [Unit] menu.

- Press the button to save the setting value.
- Press the button to change to Offline mode.
- Press the button again to change to Online mode.

You can print to check the adjusted dispenser stop position.

## Adjusting the Print Quality

---

### Adjusting the Print Darkness

The adjustment procedure for the print darkness is as follows:



- You can fine tune the print darkness by setting the [Darkness Adjust] in the [Printing] > [Advanced] > [Adjustments] menu.
  - When the [Printing] > [Advanced] > [Prioritize] menu has been set to [Commands] and the print darkness is specified by command, the data will be printed with the print darkness specified by the command.
  - You can adjust the print darkness during printing by registering the [Adjustments] menu to the [Shortcut] menu in advance.
- 

1. When the product is in Online mode, press the  button to change to Offline mode.



2. Press the  button to show the [Settings] menu.



- Input the password if it is enabled.
-

3. Press the ◀/▶ buttons to select [Printing], and then press the ⏪ button.

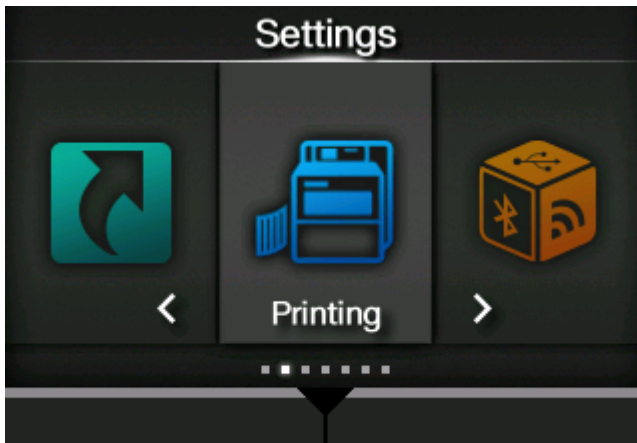

4. Press the ▲/▼ buttons to select [Darkness], and then press the ⏪ button.

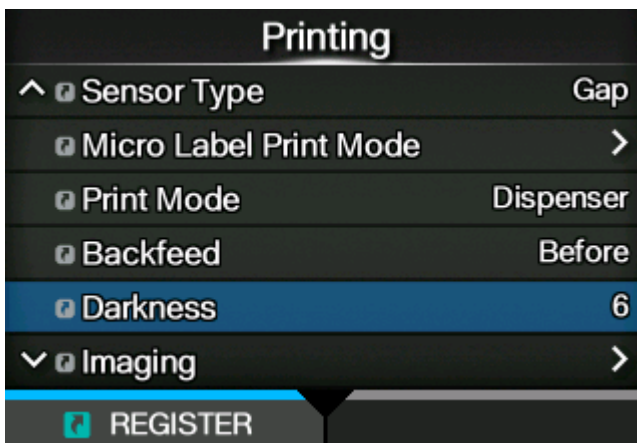

The [Darkness] screen appears.

5. Press the ▲/▼ buttons to select a value.

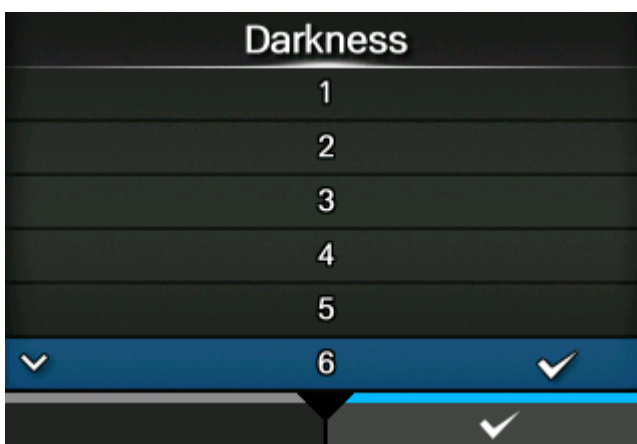

The setting range is from 1 to 10. 1 is the lightest and 10 is the darkest.

6. Press the [ ] button or ⏪ button to save the setting value.
7. Press the ▶|| button to change to Offline mode.

**8. Press the  button again to change to Online mode.**

You can print to check the print quality.

## Adjusting the Print Speed

The adjustment of the print speed not only changes the speed of printing but also affects the print quality.

The setting range of the print speed varies depending on the following print resolution:

Resolution	S84NX	S86NX
203 dpi (8 dots/mm)	4 to 16 ips (inches/sec) (101.6 to 406.4 mm/sec)	4 to 14 ips (inches/sec) (101.6 to 355.6 mm/sec)
305 dpi (12 dots/mm)	4 to 14 ips (inches/sec) (101.6 to 355.6 mm/sec)	4 to 12 ips (inches/sec) (101.6 to 304.8 mm/sec)
609 dpi (24 dots/mm)	2 to 6 ips (inches/sec) (50.8 to 152.4 mm/sec)	-



- When the [Printing] > [Advanced] > [Prioritize] menu has been set to [Commands] and the print speed is specified by command, the data will be printed with the print speed specified by the command.
- You can adjust the print speed during printing by registering the [Speed] menu to the [Shortcut] menu in advance.
- If [Enabled] is selected in the [Micro Label Print Mode] menu, the print speed has a maximum of 4 ips (inches/second).

1. When the product is in Online mode, press the  button to change to Offline mode.



2. Press the  button to show the [Settings] menu.



- Input the password if it is enabled.



3. Press the ◀/▶ buttons to select [Printing], and then press the ↩ button.

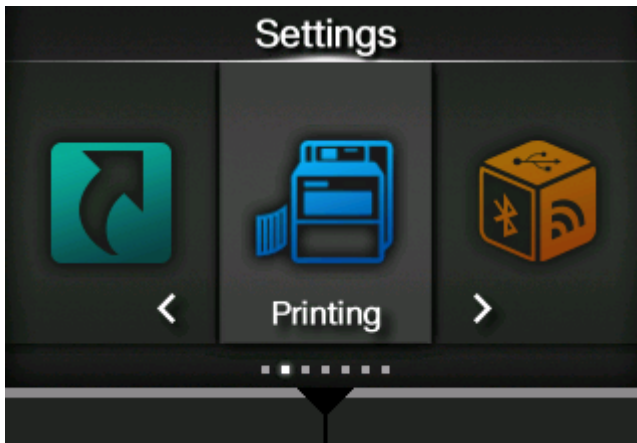

4. Press the ▲/▼ buttons to select [Speed], and then press the ↩ button.

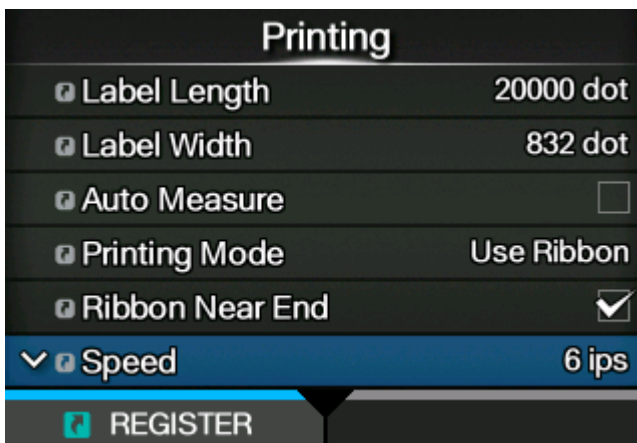

The [Speed] screen appears.

5. Press the ▲/▼ buttons to select a value.

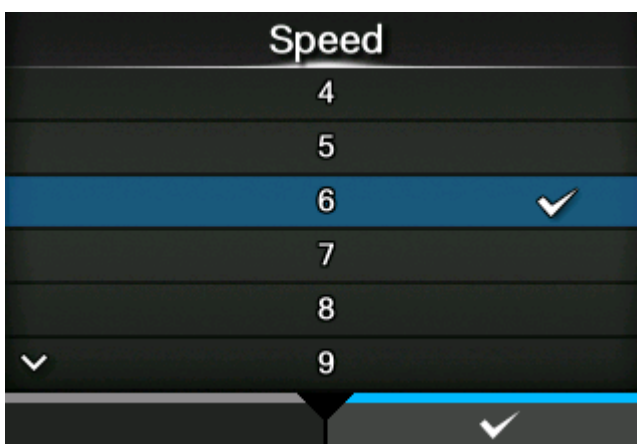

6. Press the [REGISTER] button or ↩ button to save the setting value.

7. Press the ▶|| button to change to Offline mode.

8. Press the  button again to change to Online mode.

You can print to check the print quality.

## Adjusting the Product's Buzzer Volume

The adjustment procedure for the buzzer volume when an error occurs is as follows:

1. When the product is in Online mode, press the  button to change to Offline mode.



2. Press the  button to show the [Settings] menu.



- Input the password if it is enabled.

3. Press the  buttons to select [System], and then press the  button.

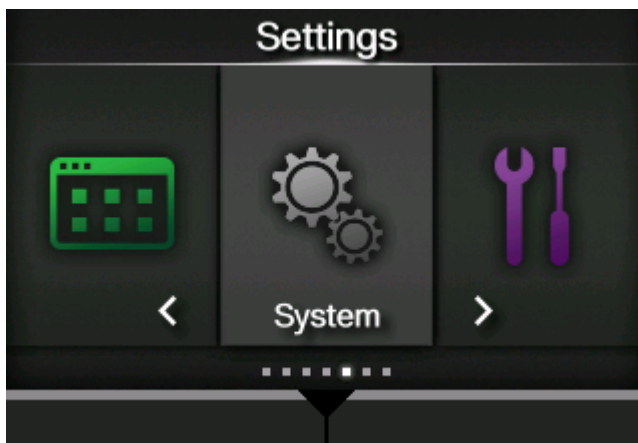

4. Press the ▲ / ▼ buttons to select [Sound] > [Error Sound], and then press the ◀ button.

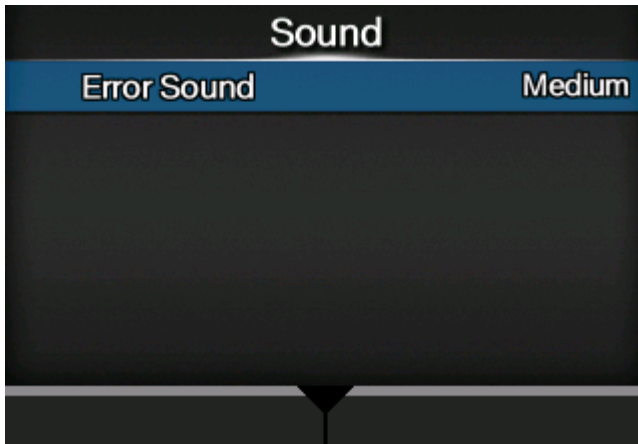

The [Error Sound] screen appears.

5. Press the ▲ / ▼ buttons to set the volume.



The options are as follows:

**[Off]**

Mute the sound.

**[Low]**

Low volume.

**[Medium]**

Medium volume.

**[High]**

High volume.

6. Press the [Enter] button or the ◀ button to save the setting.

## Adjusting the Head Pressure Balance

---

### Print Head Balance

Print head balance refers to the equalization of pressure between the print head and the platen roller. If the print head balance is out of adjustment, the printed image will be darker on one side of the media than the other and the media will be prone to travel in the direction of greater pressure.

#### **Setting the Criteria of the Head Pressure Balance**

The criteria of the head pressure balance is set to adapt to the using media.

- Set the head pressure according to the media thickness, including the liner.
- Set the pressure balance according to the media width.

## Pressure Balance Setting



Required tool

- Slotted screwdriver

The adjustment procedure for the pressure balance is as follows:

1. Open the top cover of the product.
2. Turn the head lock lever (1) clockwise to unlock the print head.

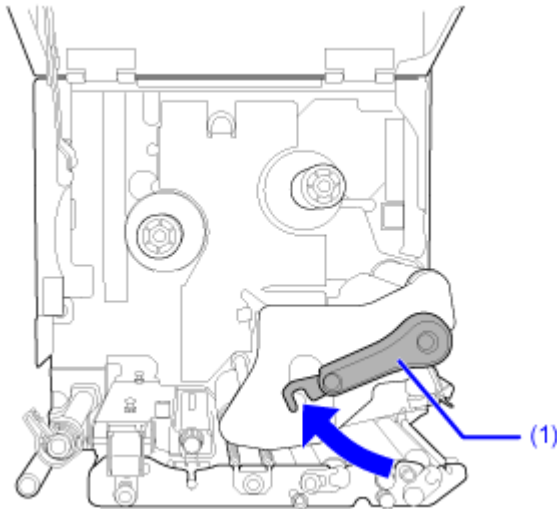

3. To expose the adjustment dial (2) beside the head lock lever as shown, turn the head lock lever (1) back until before it locks.

The numeral (3) at the bottom (looking parallel with print head) of the adjustment dial indicates the current value set for pressure balance.

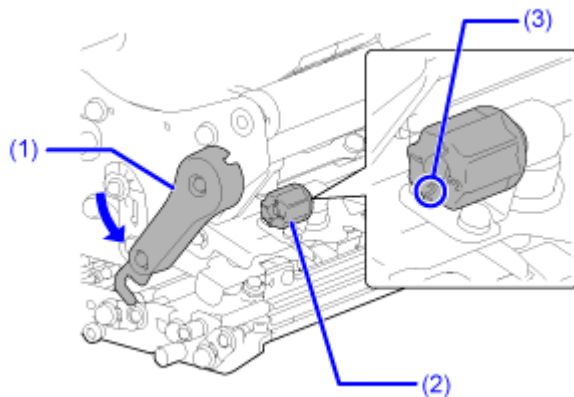

4. Use the slotted screw driver to turn the adjustment dial (2), and then set the pressure balance according to the media width and media thickness.

Media Thickness (mm (inch))		0.05 to 0.20 (0.002" to 0.0079") Thin paper/normal label, etc.		0.20 to 0.31 (0.0079" to 0.30122") Thick paper/tag, etc.	
Media Width (mm (inch))	S84NX	30 to 128 (1.18" to 5.04")	10 to 30 (0.39" to 1.18")	30 to 128 (1.18" to 5.04")	10 to 30 (0.39" to 1.18")
	S86NX	80 to 177 (3.15" to 6.97")	51 to 80 (2.01" to 3.15")	80 to 177 (3.15" to 6.97")	51 to 80 (2.01" to 3.15")
Pressure Balance Adjustment Dial		<b>1</b>	<b>3</b>	<b>2</b>	<b>4</b>



- The factory default setting is **2**.
- The thickness of the media includes the liner.
- The dial setting values in the table are only for reference, and the values may vary depending on the media type. Be sure to check if the print quality is stable by actually printing.

## Adjusting the Head Position

---

### Left - Right Pressure Balance Setting

---



Required tool

- Phillips screwdriver
- 

The adjustment procedure for the pressure balance is as follows:

- 1. Open the top cover of the product.**
- 2. Make sure that the head lock lever (1) is in the lock position.**

If it is not locked, turn the head lock lever counterclockwise to lock the print head.

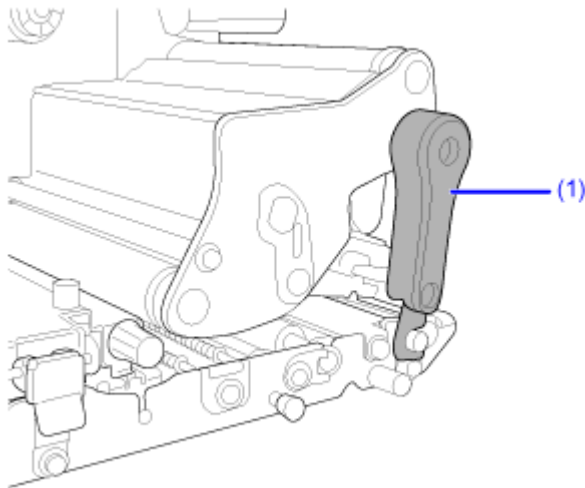

- 3. Find the adjust collar (2) on the side of the print head assembly.**

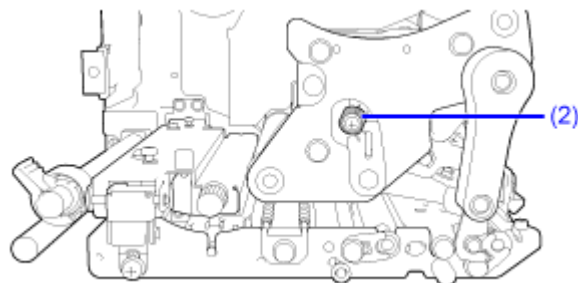



**4. Loosen the screw (3) attached to the adjust collar (2).**

Do not remove the screw.

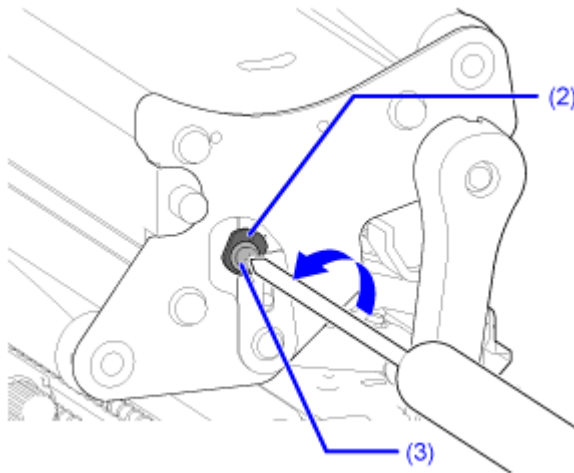

**5. Turn the adjust collar (2) to adjust the head pressure balance.**

Turn the adjust collar counterclockwise to increase the head pressure on the frame side.

Turn the adjust collar clockwise to increase the head pressure on the opposite side.

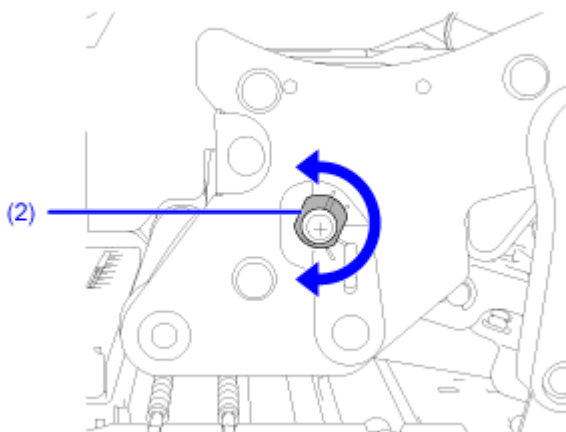

- If the product orientation is opposite from the image, the adjustment direction is reversed.

6. Hold the adjust collar (2) in the set position ① and tighten the screw (3) ②.

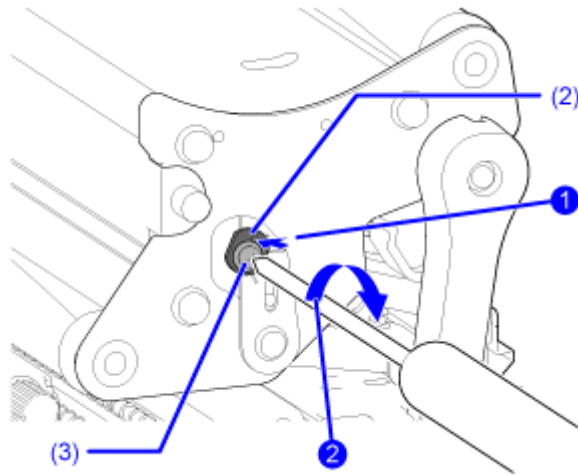

## Front - Rear Head Alignment

---



### Required tools

- Phillips screwdriver
  - Slotted screwdriver
- 

The adjustment procedure for the head alignment is as follows:

- 1. Open the top cover of the product.**
- 2. Make sure that the head lock lever (1) is in the lock position.**

If it is not locked, turn the head lock lever counterclockwise to lock the print head.

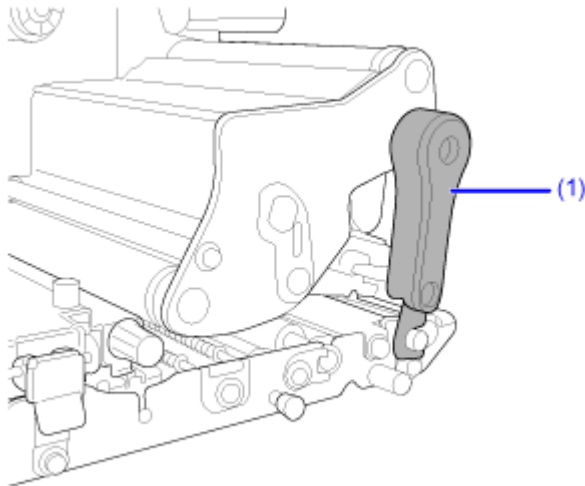

- 3. Find the two screws on the front of the print head assembly.**

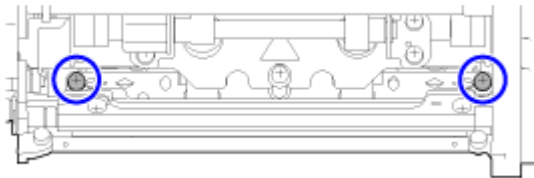

**4. Loosen the two screws using the Phillips screwdriver.**

Do not remove the screws.

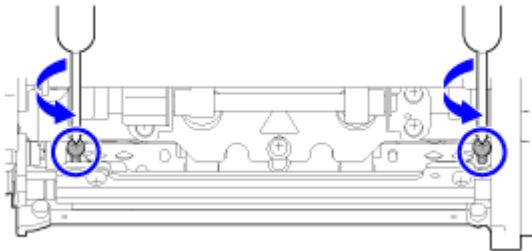

**5. Insert the slotted screwdriver into the regulation apertures ① on the left and right sides. Adjust the head position by turning the slotted screwdriver in the relevant direction ②.**

Direction (A): Print head position moves forward.

Direction (B): Print head position moves backward.

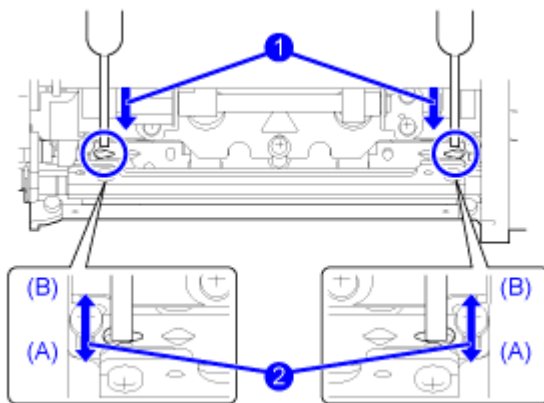

**6. Tighten the two screws.**

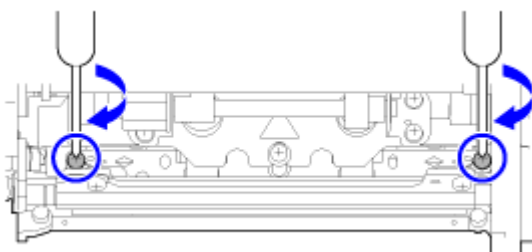

## Adjusting the Ribbon Tension Balance

If the ribbon is not spread smoothly over the print head, print voids will occur at the point of the ribbon fold. Typically, this is the result of the axis of the ribbon spindle, print head and the ribbon adjustment plate not being perfectly parallel.



Required tool

- Phillips screwdriver
- 

The adjustment procedure for the ribbon tension is as follows:

1. Open the top cover of the product.
2. Turn the head lock lever (1) clockwise to unlock the print head.

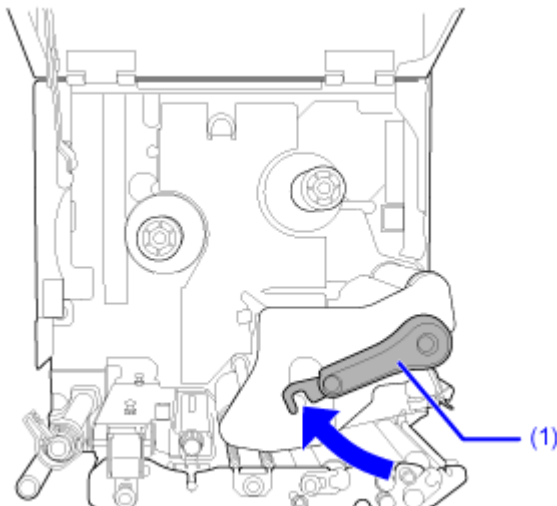

3. Find the two screws on the front of the print head assembly.

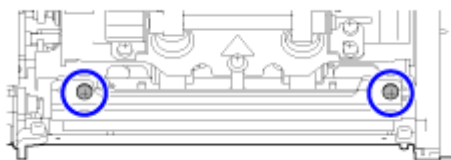

4. Loosen the two screws attached to the ribbon adjustment plate.

Do not remove the screws.

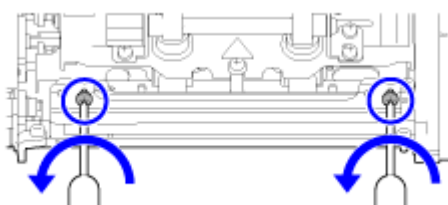

**5. Adjust the ribbon adjustment plate (2) as shown below.**

Adjust the left side of the plate upward **1** when a wrinkle occurs on the right.

Adjust the right side of the plate upward **2** when a wrinkle occurs on the left.

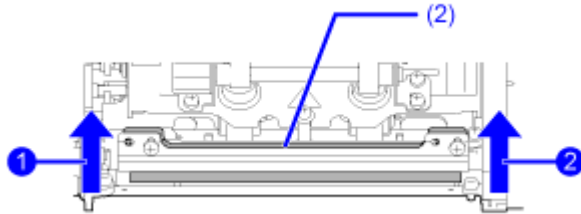

**6. Hold the ribbon adjustment plate (2) in the set position **1** and tighten the two screws **2**.**

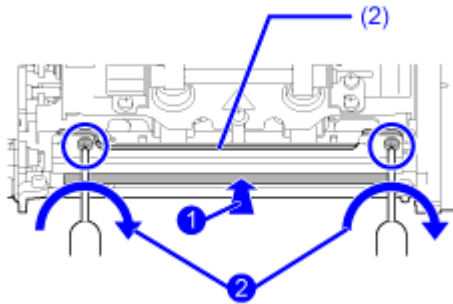

**7. Perform a test print to check the printing quality.**

The ribbon must not be wrinkled or meander.

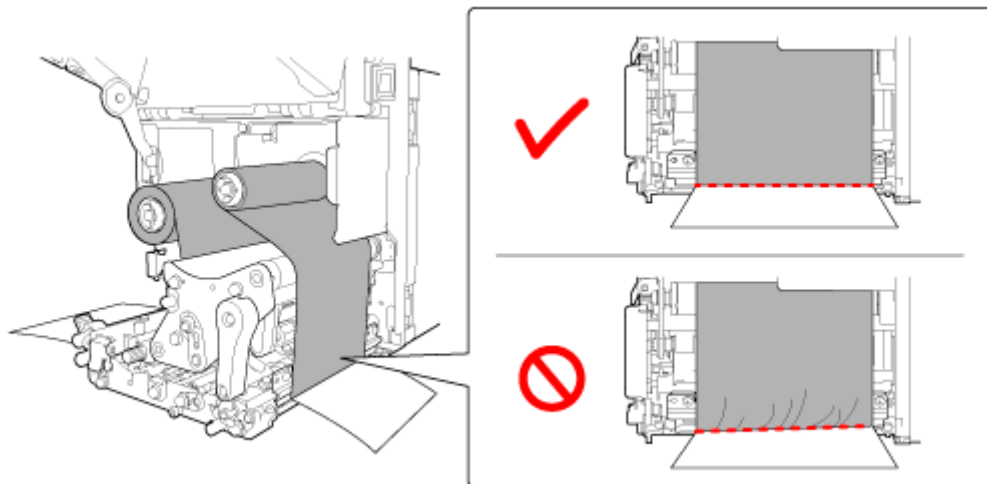

**8. Repeat the procedure from steps 1 through 6 until the ribbon tension is even on both sides.**

## RFID Settings (S84NX Only)

---

### Usable RFID Standards

The RFID standards that can be used are as follows:

- UHF (920 MHz)  
ISO/IEC18000-6 Type C

## Configuring the Product to Encode Inlays

This topic explains the procedures on how to configure the product to encode your inlays.

### 1. Examine the media to determine the product settings.



Refer to the Inlay Configuration Guide for the measurements you should take and what they mean, as well as a list of inlays and their required configurations.

To see the Inlay Configuration Guide, access the following URL:

<https://www.sato-global.com/rfid/guide.html>

To use inlays that are not in the Inlay Configuration Guide, contact your SATO sales representative or reseller.

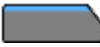
### 2. Press the power (I/O) switch to "I" position to power on the product.

3. When the product is in Online mode, press the  button or  button on the operator panel to change to Offline mode.



4. Press the  button to show the [Settings] menu.

5. Press the  buttons to select [Interface] and then press the  button.

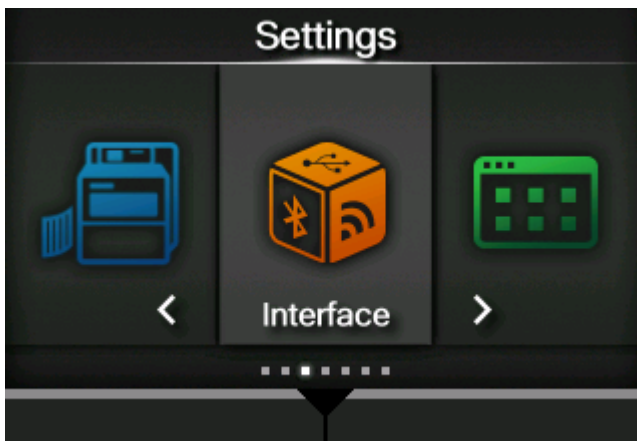



6. Press the ▲ / ▼ buttons to select [RFID] and then press the ← button.

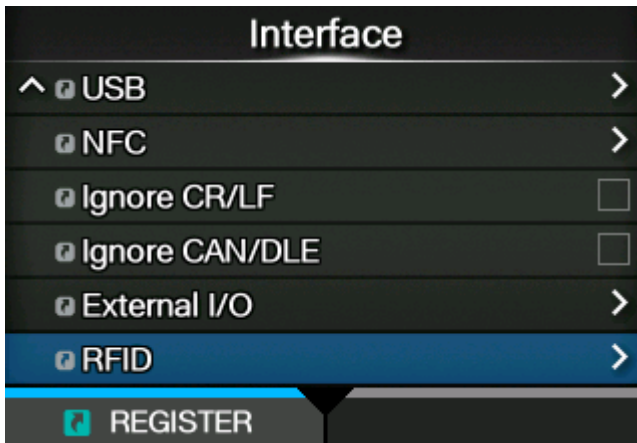

The [RFID] screen appears.

7. Press the ▲ / ▼ buttons to select the item you want to set and then press the ← button.

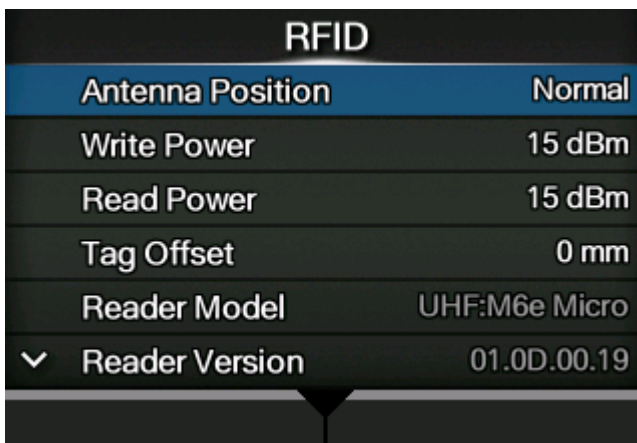

The adjusting screen appears.

8. Load the media and ribbon.
9. Confirm the operation by printing/encoding a media.

Make sure that you read the data and check that it is correctly encoded.

## Loading the RFID Tag Model



By registering settings, such as the antenna positions and writing/reading frequency outputs for each RFID tag you are using, you can easily change the product's settings when you switch RFID tags.

RFID tag models can be selected from the [Interface] > [RFID] > [RFID Tag Model] > [Load] menu and applied to the product.

The procedure to load the RFID tag model is as follows:

1. When the product is in Online mode, press the  button on the operator panel to change to Offline mode.



2. Press the  button to show the [Settings] menu.
3. Press the  buttons to select [Interface], and then press the  button.

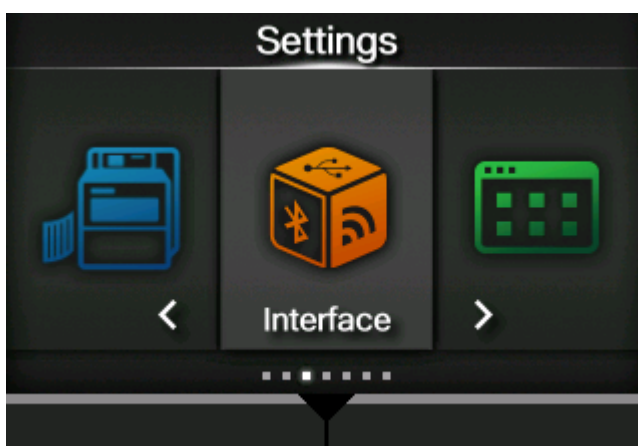

4. Press the ▲ / ▼ buttons to select [RFID] > [RFID Tag Model], and then press the ↩ button.

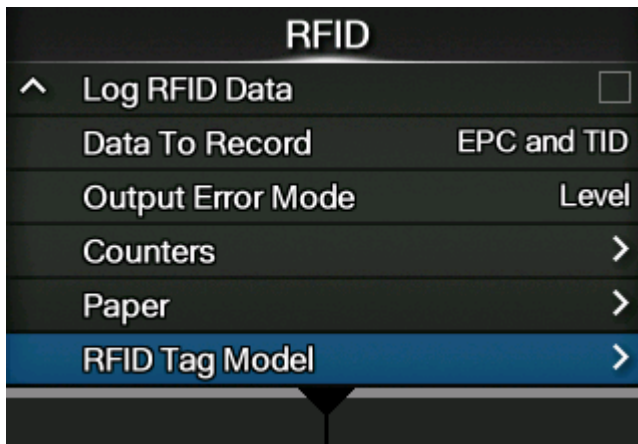

5. Press the ▲ / ▼ buttons to select [Load], and then press the ↩ button.

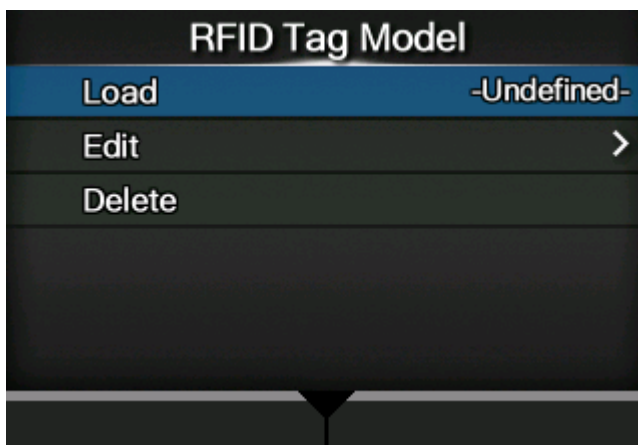

6. Press the ▲ / ▼ buttons to select the RFID tag model to load.

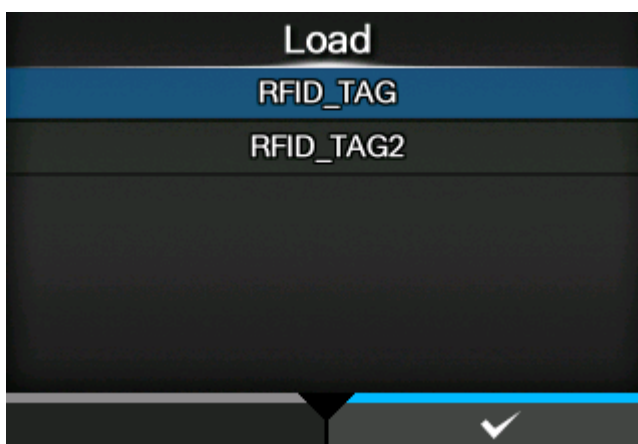

7. Press the [button] button or ↩ button to confirm.

8. Press the  button on the confirmation screen.

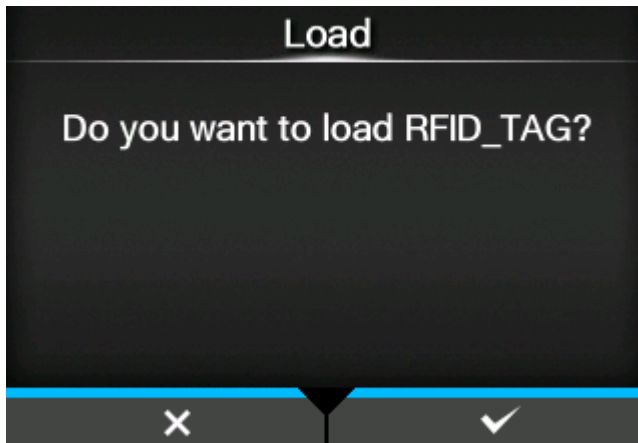

9. Press the  button on the completion screen.

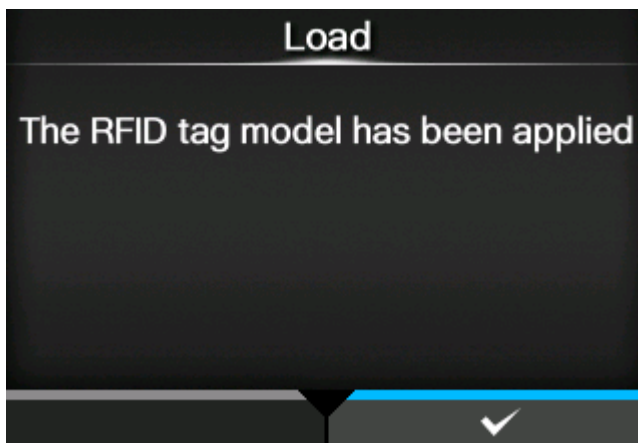

The settings loaded from the RFID tag model are applied to the product. The name of the loaded RFID tag model appears on the right side of [Load] on the [RFID Tag Model] menu.

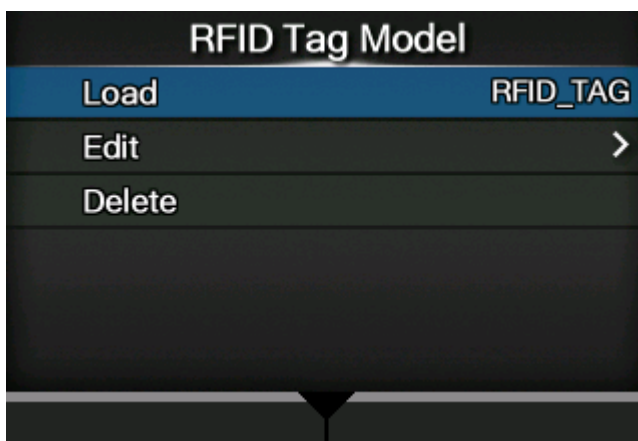

- From the [RFID Tag Model] > [Edit] menu, you can change settings in registered RFID tag models or manually register new RFID tag models.

## Printing RFID Tag Errors

If the recorded data on a tag is incomplete due to writing on a defective tag, the product will print an RFID tag error to the defective media. This function is to prevent the distribution of defective media with a tag error.

When an RFID tag error occurs, the product prints a slash and the error message, such as "WRITE TAG ERROR" or "TAG NOT FOUND". The position to print the message and slash is set using the specified media size command <A1>.

For a write error such as "WRITE TAG ERROR", the product continues to print the first 16 or 32 bytes of the write data.

The diagram below shows the message and slash printed on the position based on the media size specified by the normal print.



- The following figures show an example of Opposite/Right-Hand Type.

**WRITE TAG ERROR in RFID Write Command**

**READ TAG ERROR in RFID Read Command**

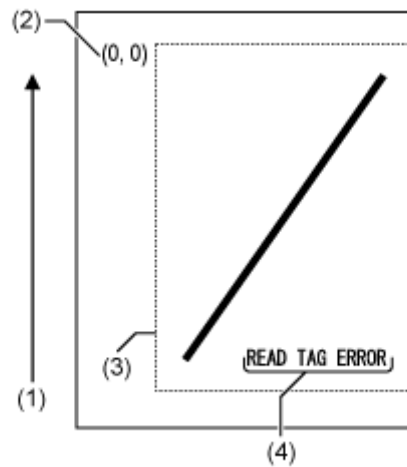
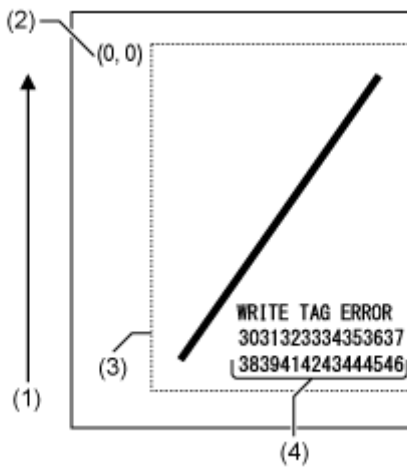

For other errors, the product prints the error message accordingly.

**TAG NOT FOUND Error in RFID Write/Read Command**

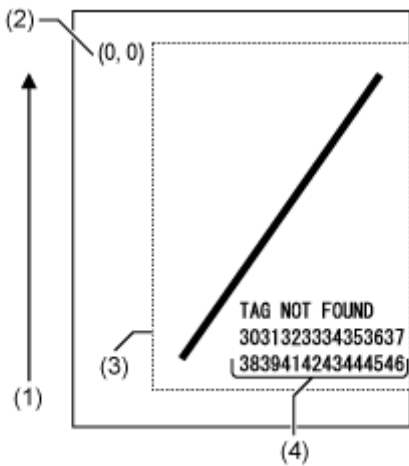

- (1) Feed direction
- (2) The origin of the range specified by the media size command <A1>
- (3) The range specified with the media size command <A1>
- (4) The dump for the first 16 or 32 bytes of the write data



- When a character overlaps with the slash, the character will inverse from black to white.



When using a small-size label (about the size of P30 X W40 mm (P1.18" X W1.57"), for example) or not enough for setting margin, the slash and error message are printed overlap on each other. The overlapped area are inverse from black to white. There is no dump printing.

**TAG NOT FOUND Error in RFID Write Command**

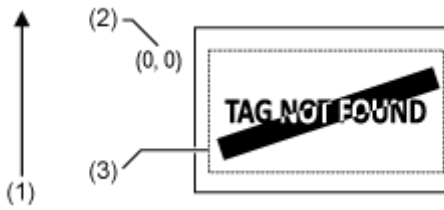

- (1) Feed direction
- (2) The origin of the range specified by the media size command <A1>
- (3) The range specified with the media size command <A1>

If not specified by the media size command <A1>, the product prints the RFID error using a fixed size of P30 X W40 mm (P1.18" X W1.57"). When a character overlaps with the slash, the character will inverse from black to white.

**WRITE TAG ERROR in RFID Write Command      READ TAG ERROR in RFID Read Command**

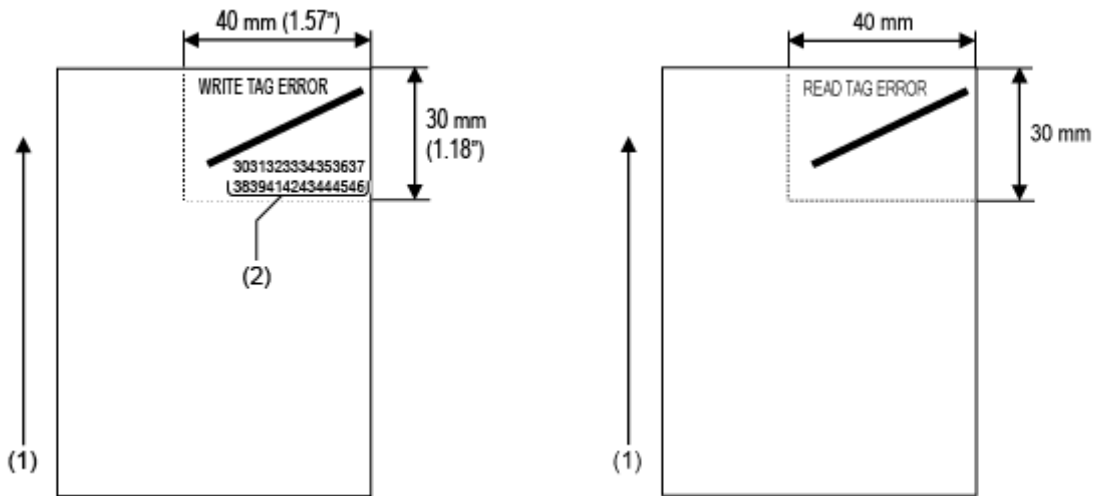

For other errors, the product prints the error message accordingly.

**TAG NOT FOUND Error in RFID Write/Read Command**

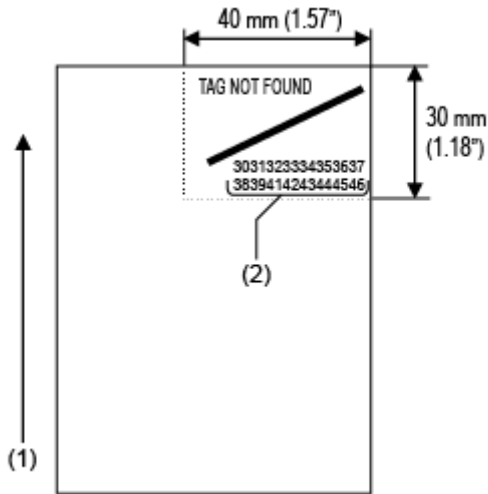

- (1) Feed direction
- (2) The dump for the first 16 or 32 bytes of the write data

The layout of a tag error print (horizontal position of reference point) varies according to the product orientation as shown below. The vertical position of the reference point and print content do not change.

**Standard/Left-Hand Type**

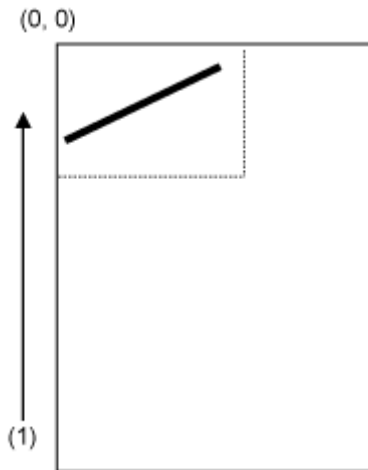

**Opposite/Right-Hand Type**

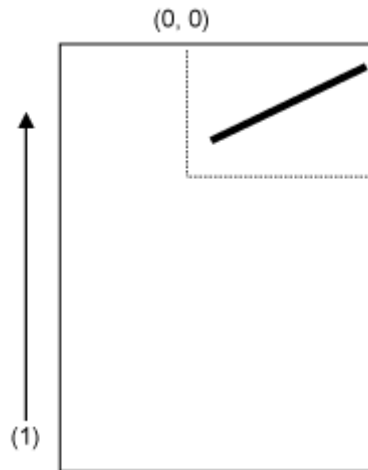









- (1) Feed direction

The types of errors to print are as follows:

Message	Cause and Countermeasure
TAG NOT FOUND	 <a href="#">Error Message 1114 (Tag not Found) (S84NX Only)</a>



Message	Cause and Countermeasure
WRITE TAG ERROR	 <a href="#">Error Message 1115 (Write Tag Error) (S84NX Only)</a>
READ TAG ERROR	 <a href="#">Error Message 1116 (Failed to Read the Tag Data) (S84NX Only)</a>
VERIFY UID ERROR	 <a href="#">Error Message 1116 (Failed to Read the Tag Data) (S84NX Only)</a>
VERIFY TAG ERR.	 <a href="#">Error Message 1118 (Write/Read Values Are not Consistent) (S84NX Only)</a>
LOCKING ERROR	 <a href="#">Error Message 1119 (Failed to Lock the Data) (S84NX Only)</a>
MULTI TAGS ERROR	 <a href="#">Error Message 1121 (Multiple Tags Are Detected) (S84NX Only)</a>
READ ONLY ERROR	 <a href="#">Error Message 1123 (Write Tag Error) (S84NX Only)</a>
POWER NOT ENOUGH	 <a href="#">Error Message 1126 (Not Enough Power) (S84NX Only)</a>

## RFID Printing Tips

### Recommended Non-printable Zone

Avoid printing barcodes or characters directly on top of an RFID chip. The uneven surface will negatively affect the print quality.

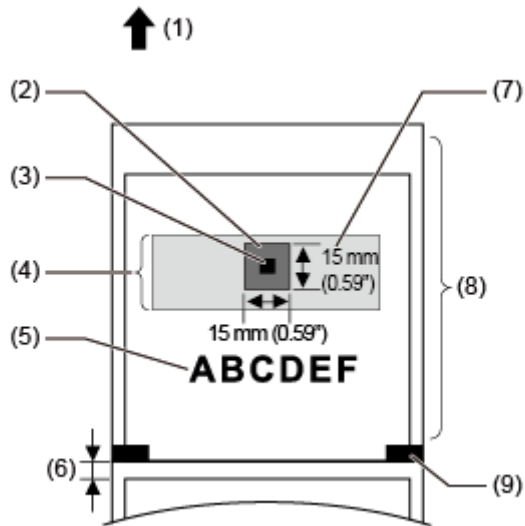



- (1) Feed direction
- (2) Recommended non-printable zone
- (3) IC chip
- (4) Inlay
- (5) Print object
- (6) Gap
- (7) Antenna
- (8) RFID tag/label
- (9) I-mark

## Configuring Optional Barcode Check Function

### Basic Specifications of the Barcode Check Function

The barcode check function does a reading check of a barcode printed by this product to prevent the distribution of labels with defective barcodes. You can use this function by installing the supported barcode checkers to the product.

The basic specifications of the barcode check function are as follows:

Item	Specification
Supported Barcode Checkers	<ul style="list-style-type: none"> <li>• Made by DATALOGIC (USB connection)               <ul style="list-style-type: none"> <li>◦ GFS4170 (for 1D barcodes)</li> <li>◦ GFS4470 (for 1D barcodes/2D codes)</li> </ul> </li> </ul> <p>Refer to the manual of the barcode checker for its settings and supported barcodes.</p>
Supported Commands	SBPL/SZPL/SIPL/SDPL <hr/>  <ul style="list-style-type: none"> <li>• AEP is not supported.</li> </ul> <hr/>
Supported Print Modes	Continuous mode only <hr/>  <ul style="list-style-type: none"> <li>• Not available for S84NX RFID models.</li> </ul> <hr/>
Print Speed/Print Darkness	The optimal print speed and print darkness for secure reading vary depending on various conditions, such as the barcode type and label layout. Be sure to perform a test read carefully and determine the settings.
Printable Area (Barcode Readable Area)	Same as the product specifications. However, there are following restrictions: <p><b>Continuous mode</b></p> Barcodes printed within the specified range from the trailing end of the label cannot be read because they are blocked by the print head

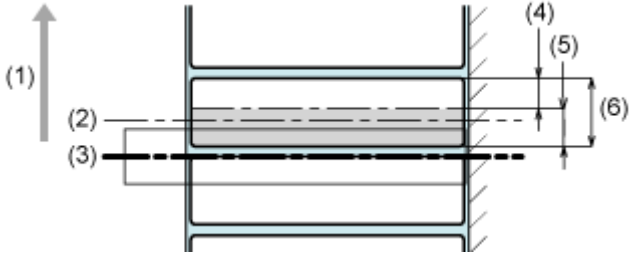
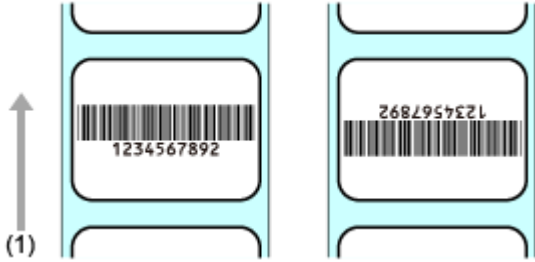
Item	Specification	
	<p>and ribbon adjustment plate. The unreadable length depends on the model and the type of media sensor being used.</p>  <p>(1) Media feed direction                  (2) Ribbon adjustment plate                  (3) Print head                  (4) Readable area (for the minimum media pitch)                  (5) Unreadable area                  (6) Minimum media pitch</p>	
Usable Media Sizes	Media width	Same as the product specifications.
	Media Pitch	Length of barcode being tested + unreadable length or more
Usable Media Types	Same as the product specifications. If the label color is silver or laminated, however, it makes it difficult for the barcode checker to read the barcode, as the light of the barcode checker may cause a reflection on the label surface. Be sure to do a test read carefully in advance.	
Readable Barcode Orientations	1D Barcode Checker	 <p>(1) Media feed direction</p>

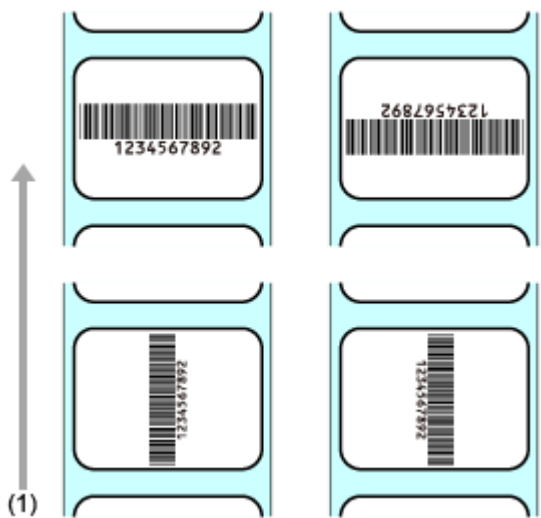
Item		Specification
	2D Code Checker	 <p>(1) Media feed direction</p> <p>Place the barcode within the size of the visual field. Do a test read carefully in advance.</p>
Recommended Barcode Sizes	1D Barcode	<p>Narrow bar: 0.25 mm (0.01") or greater</p> <ul style="list-style-type: none"> <li>• 203 dpi: 2 dots or more</li> <li>• 305 dpi: 3 dots or more</li> <li>• 609 dpi (S84NX only): 6 dots or more</li> </ul> <p>Refer to the specifications of each barcode checker.</p>
	2D Code	<p>Cell size: 0.25 mm (0.01") or greater</p> <ul style="list-style-type: none"> <li>• 203 dpi: 2 dots or more</li> <li>• 305 dpi: 3 dots or more</li> <li>• 609 dpi (S84NX only): 6 dots or more</li> </ul> <p>Refer to the specifications of each barcode checker.</p> <p>The size of the visual field conforms to the specifications of the barcode checker.</p>

**Available Code Formats**

The barcode check function supports the following code formats. Check the specifications of the barcode checker to ensure compatibility with the available code types.

Code Type	Available code formats
1D Barcodes	<p>CODABAR(NW-7)</p> <p>CODE39, CODE93, CODE128</p> <p>JAN/EAN-13/8</p> <p>UPC-A/UPC-E</p>

Code Type	Available code formats
	ITF Industrial 2 of 5 Matrix 2 of 5 MSI GS1-128 POSTNET IMB (USPS) GS1 DataBar Omnidirectional GS1 DataBar Truncated GS1 DataBar Limited GS1 DataBar Expanded GS1 DataBar Stacked GS1 DataBar Stacked Omnidirectional GS1 DataBar Expanded Stacked
2D Codes	PDF417 Micro PDF417 Maxi Code QR Code Micro QR Code Data Matrix Aztec Code
Combined Symbols	JAN/EAN-13/8(CC-A/CC-B) UPC-A/UPC-E(CC-A/CC-B) GS1-128(CC-A/CC-B/CC-C) GS1 DataBar(CC-A/CC-B)



- To use the comparison mode, create barcodes by using barcode commands. If a barcode such as graphic data (BMP image, etc.) or a preprinted barcode is placed within the barcode readable area, this mode may not function correctly.



- In readable mode, you can include barcodes that are not created by barcode commands (such as graphic data or preprinted barcodes) as the check target. To do this, select [Setting] in [Set No. of Barcodes], and specify the number of barcodes per label in [Barcodes per Label]. However, there may be a case that those barcodes cannot be read by scanners thus this mode does not function correctly.

## Setting Up the Barcode Checker

### Operational Settings for the Barcode Checker and Installation

To use the barcode check function, perform necessary operational settings for the supported barcode checker and then install it to the product.

#### Operational Settings for the Barcode Checker

Set up the barcode checker either by using the application software provided by its manufacturer or by reading the barcodes for setting changes printed on the barcode checker's manual. For details, refer to the manual.

- **Settings common to all supported barcode checkers**

Limit the barcode types you permit the barcode checker to read as much as possible. If a lot of barcode types are permitted, a longer decode time is required. This can cause the barcode checker to fail to read the printed barcode.

- **GFS4170, GFS4470**

- Select USB-COM. The product cannot detect the barcode checker when connected with other settings.

- **GFS4470**

- To shorten laser lighting time, it is recommended to set the reading mode to "On Line" or "Serial On Line".
- If multiple barcodes are captured at once when using the default barcode checker settings, only the first set of decoded barcode data is sent. You can change the settings to decode and send all the captured barcodes. However, if this is done, combined symbols cannot be read.
- When printing barcodes in a narrow range, allow enough time for decoding (parameter: DETM), otherwise not all of the results of the decoded captured barcodes will be sent.
- Because postal barcodes consist of bars and spaces with equal intervals, they may be read as a different barcode type. When checking postal barcodes, it is recommended to set other barcode types to be unreadable.

### Doing a Test Read with the Barcode Checker

Prepare a label on which the barcode data you use is printed by this product.

After performing operational settings of the barcode checker and then connecting it to the product, perform a test read from the product's [Settings] menu to confirm that the barcode checker functions correctly.

- 1. After connecting the barcode checker, press the power (I/O) switch to "I" position to power on the product.**

When the product is powered on, the barcode checker is also powered on automatically.

-  When the barcode checker is powered on, it emits a laser light. Be sure to keep the laser away from your eyes.
- When using GFS4170, it keeps emitting a laser light while the product is powered on. To turn off the laser light, power off the product.

Once the connection between the product and the barcode checker is complete, the barcode checker icon appears on the status bar of the display.



2. When the product is in Online mode, press the  button on the operator panel to change to Offline mode.



3. Press the  button to show the [Settings] menu.



4. Press the ◀/▶ buttons to select [Tools], and then press the ↩ button.

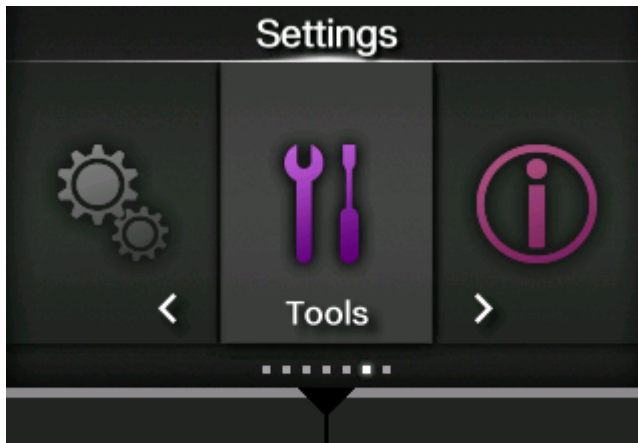

5. Press the ▲/▼ buttons to select [Barcode Checker] > [Test], and then press the ↩ button.

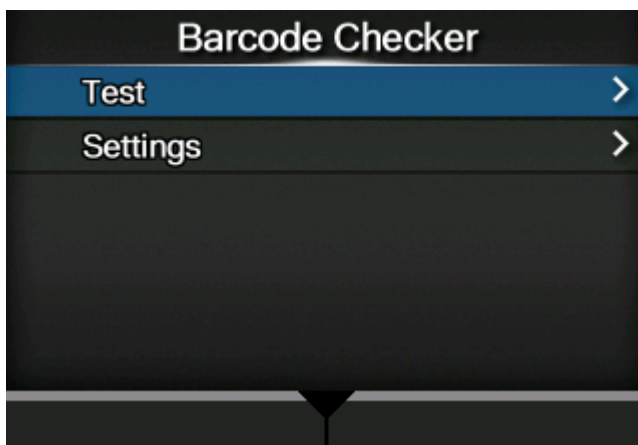

6. Confirm that the type of connected barcode checker is displayed on the right side of [Reader Name].

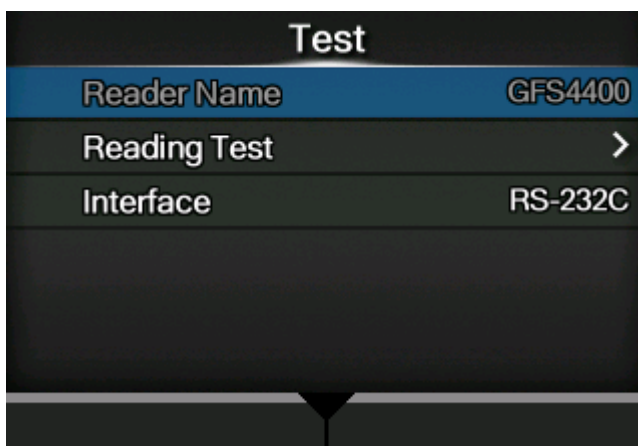

7. Press the ▲/▼ buttons to select [Reading Test], and then press the ↩ button.

8. Set a label with barcodes within the scanning range of the barcode checker.

9. Press the  button to start reading the barcodes.

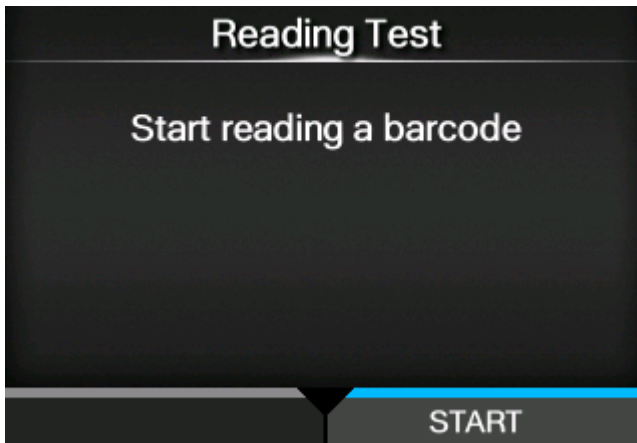

If reading is successful, the barcode type and data read are displayed on the screen. Only the first 23 bytes of data are displayed.

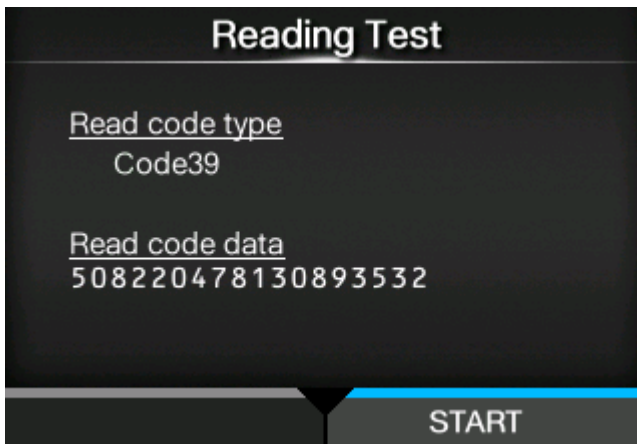

If reading is unsuccessful, or the displayed results of the read are not correct, adjust the position of the barcode checker. For details on how to use the barcode checker, refer to the manual that came with the barcode checker.



- If the product cannot detect the barcode checker, check if the operational settings for the barcode checker are appropriate.
-

## Enabling the Barcode Check

### Selecting the Barcode Check Mode



The barcode check function has a readable mode and a comparison mode. You can switch the mode or disable the function from the product's [Settings] menu.



- The barcode check function is available only when the print mode is set to continuous mode. To use this function, select [Continuous] in the [Printing] > [Print Mode] menu.

1. When the product is in Online mode, press the  button on the operator panel to change to Offline mode.



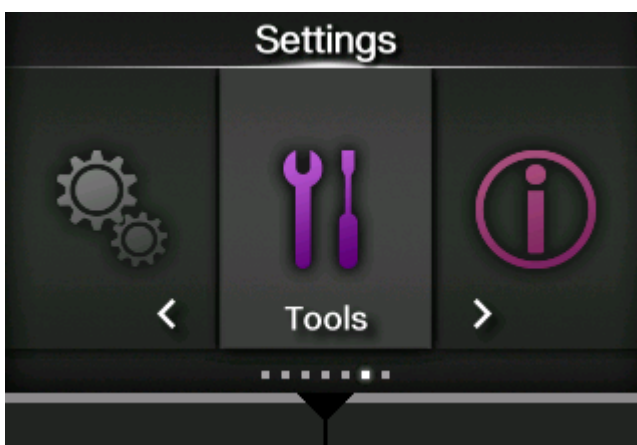

2. Press the  button to show the [Settings] menu.
3. Press the  buttons to select [Tools], and then press the  button.

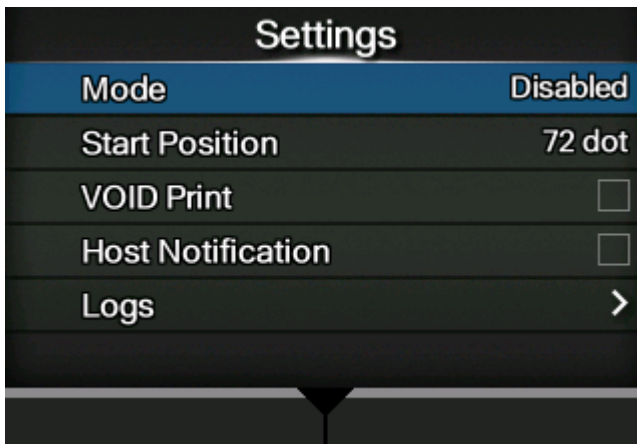

4. Press the  /  buttons to select [Barcode Checker] > [Settings] > [Mode], and then press the  button.



5. Press the  /  buttons to select the mode for the barcode check function.

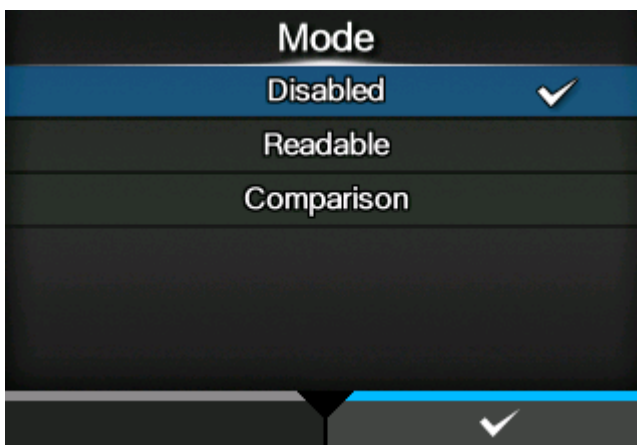

**[Disabled]**

Disable the barcode check function.

**[Readable]**

Enable readable mode.

**[Comparison]**

Enable comparison mode. This mode is for barcodes created by barcode commands.

6. Press the  button to save the setting value.



- When the readable mode or comparison mode is set, a barcode reader connection error occurs if the barcode checker is not connected at product startup or at the start of printing.
- Even if the readable mode or comparison mode is set, the barcode check is not done for print data that does not include any barcode data. Normal printing is done for that data.

- In the readable mode, to include barcodes that are not created by barcode commands (such as graphic data or preprinted barcodes) as the check target, select [Setting] in [Set No. of Barcodes], and specify the number of barcodes per label in [Barcodes per Label].
- When [VOID Print] is enabled, you can identify a defective label by printing error marks on it.
- The log data of barcode check results is saved on the product and can be copied to the USB memory from the [Logs] menu. By enabling [Host Notification], you can also return check results to the host from which the print data is sent.

## Contents of the Check for Readable Mode and Comparison Mode

The barcode check function has readable mode and comparison mode. The contents of the check for each mode are as follows.



- You can check multiple barcodes on one label. Though the number of barcodes on one label is not limited, a reading error occurs when the total size of the barcode data exceeds 200 Kb.
- In the readable mode, you can include barcodes that are not created by barcode commands (such as graphic data or preprinted barcodes) as the check target, but you need to specify the number of barcodes per label in advance. Select [Setting] in [Set No. of Barcodes], and specify the number of barcodes per label in [Barcodes per Label].
- Reading of barcodes starts after the label length specified in [Start Position] passes. In modes where the product backfeeds before printing, the product backfeeds first, and then feeds the length of the start position.

### Readable mode

This mode checks if the printed barcodes are readable. The readability is determined by whether the number of barcodes the barcode checker reads matches the number of barcodes in the print data.

- The reading is considered to be successful if the number of barcodes the barcode checker reads reaches the number of barcodes in the print data. The product prints the next label.

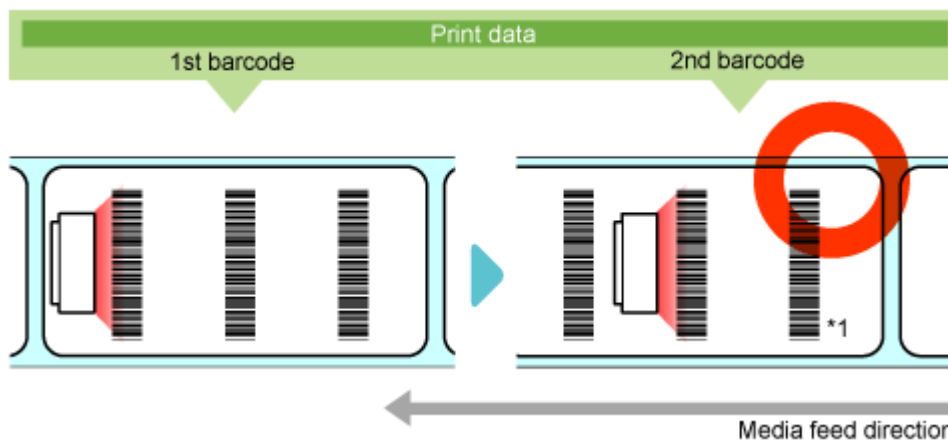

\*1 Even if the number of barcodes the barcode checker reads exceeds the number of barcodes in the print data, it is considered to be successful.

- A reading error occurs if the number of barcodes in the print data is not read within the printing period from start to finish and the timeout period (up to 2 seconds).

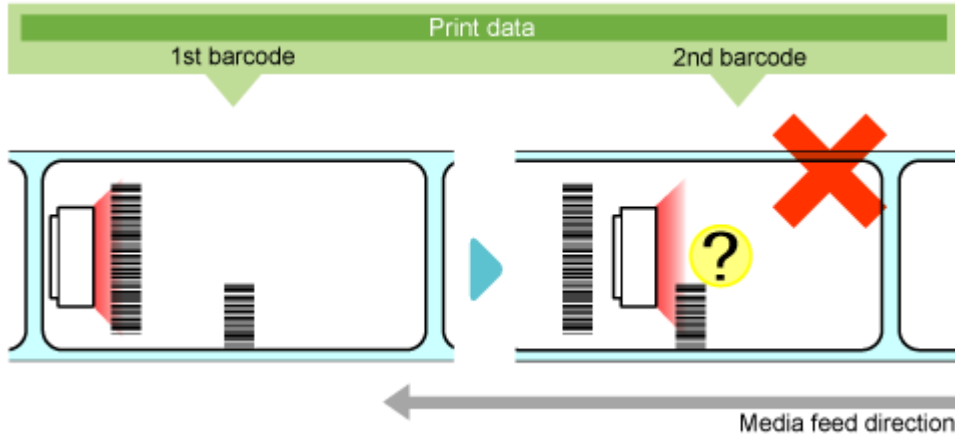

**Comparison mode**

This mode checks if the read results of the printed barcodes match the barcode data in the print data.

- The reading is considered to be successful if the read results of the printed barcodes match the barcode data in the print data. The product prints the next label.

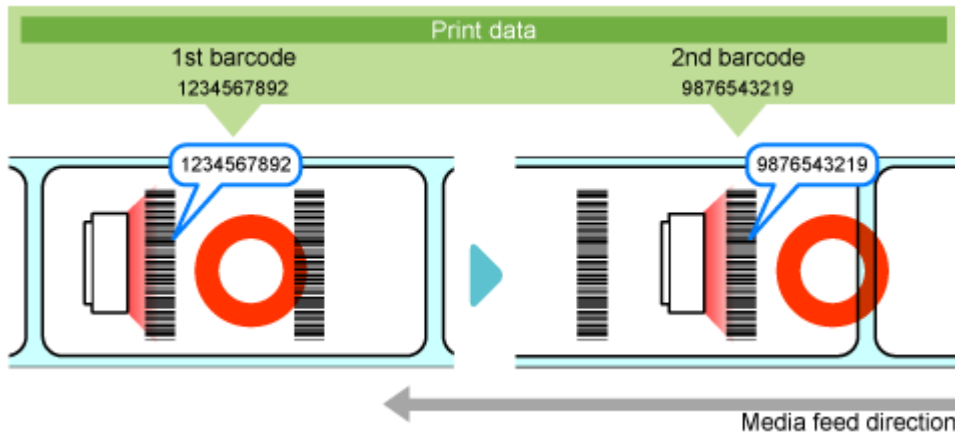

- A comparison error occurs if the read results of the printed barcodes do not match the barcode data in the print data.

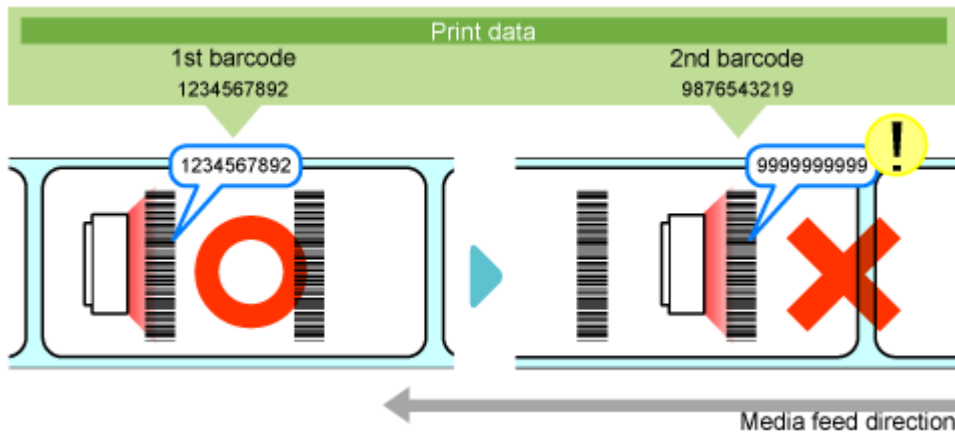

- A reading error occurs if the number of barcodes in the print data is not read within the printing period from start to finish and the timeout period (up to 2 seconds), even if the read results of the printed barcodes do not match the barcode data in the print data.

## Restrictions for the Barcode Check Function

### Common Restrictions for the Barcode Check Function

- 
 When the product is powered on while the barcode checker is connected, the barcode checker is also powered on and emits a laser light. Be sure to keep the laser away from your eyes.
- The reading accuracy of barcodes or 2D codes is affected by label conditions (label curl, print quality, etc.) and the usage environment (ambient light, temperature, humidity, etc.), and readability is not guaranteed. Be sure to do a test read with the barcode checker you will use in advance.
- The types of paper that can be used are the same as the product specifications. If the label color is silver or laminated, however, it makes it difficult for the barcode checker to read the barcode, as the light of the barcode checker may cause a reflection on the label surface. Be sure to do a test read carefully in advance.
- Design the label layout so that barcodes or 2D codes do not remain within the scanning range of the barcode checker at the completion of printing. If the barcode of the previous label remains in the scanning range at the start of the next printing, the barcode checker may read the same barcode twice.

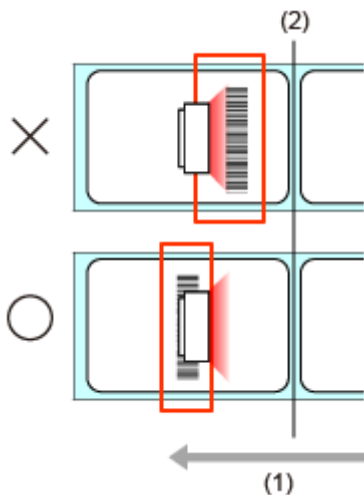

(1) Media feed direction

(2) Print head position

- Barcodes printed within the following range from the print end position cannot be read and a reading error inevitably occurs. The range varies depending on the model or media sensor being used. As the following table is only for a reference, be sure to do a test read carefully in advance.

Media Sensor Type	S84NX	S86NX
Gap	6.5 mm (0.26")	8.7 mm (0.34")
I-mark	9.5 mm (0.37")	11.7 mm (0.46")



- The barcode check is not performed if the position at which the check starts is detected after the label feeding begins to stop. Define the label layout and position at which the check starts by keeping in mind that the distance required for stopping is proportional to the print speed.
- Printed barcodes or 2D codes can be read only with a size at which their entire pattern is within the scanning range of the barcode checker. A reading error may occur depending on the print position.
- When powering on the product, do not connect or disconnect the barcode checker. The product may not operate properly.
- The barcode data that can be read for 1 item is up to 200 bytes per barcode and up to 200 Kb in total.

#### **Restrictions When Using GFS4170**

- It keeps emitting a laser light while the product is powered on. To turn off the laser light, power off the product.

#### **Restrictions When Using GFS4470**

- By the double-reading prevention function, the barcode checker may not read barcodes that are printed successively if they are within the readable area. Adjust the print position so that same barcodes are not within the readable area.
- When printing composite symbols that use GS1 DataBar, the read data and print data never match if the barcode data is 16 digits or less. A comparison error occurs in comparison mode.
- Though "\" (0x5C) specified in MAXI code, print data should be read as "\\\" in the specifications. However, it may not be read as such, depending on the following data. For example, "\A" specified in print data should be read as "\\A" in the specifications, but it is actually read as only "A".

## Initializing the Product

### Procedures for Initializing

Initialize the product's data and setting values.



- It is generally not necessary to perform the initialization. Doing so could change the print conditions.
- You cannot recover the data and settings that are lost because of initialization. Before doing an initialization, make a backup if needed. You can back up the product's data and setting values by using the following function in the [Tools] menu.
  - [Clone]: Copies the current data and settings to the USB memory. To recover the data and setting values, use the USB memory to take the .pkg file that was created, and then apply them to the product.



- The data that is initialized is the fonts and graphics registered in the product.

1. If the product is in Online mode, press the  button to go to Offline mode.



2. Press the  button to show the [Settings] menu.

3. Press the ◀/▶ buttons to select [Tools], and then press the ↩ button.

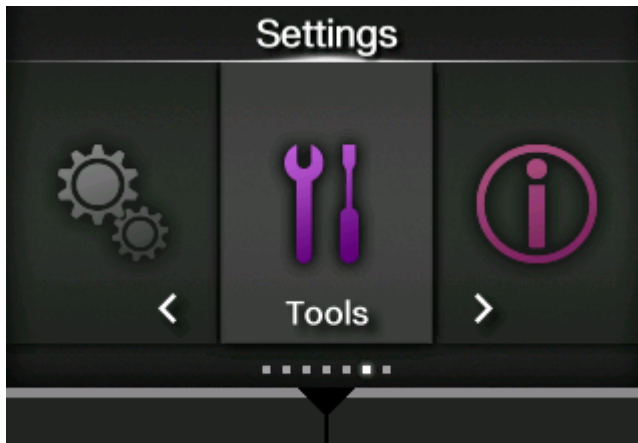

4. Press the ▲/▼ buttons to select [Reset], and then press the ↩ button.

5. Select a type of reset.

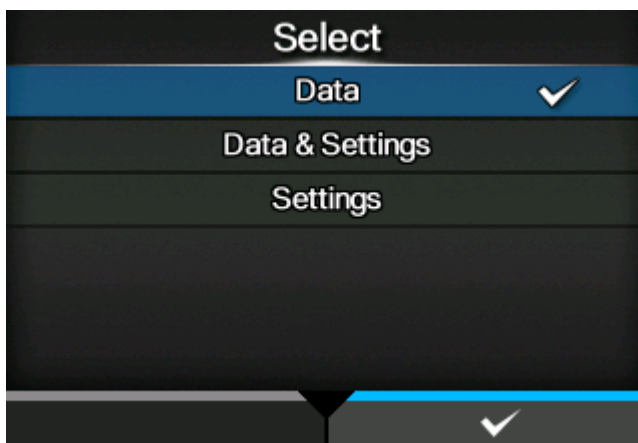

**[Data]**

Initialize the data saved in the product.

**[Data & Settings]**

Initialize the product's data and setting values.

**[Settings]**

Initialize the product's setting values.

6. If you selected [Data & Settings] or [Settings], you can select the setting items to be initialized.

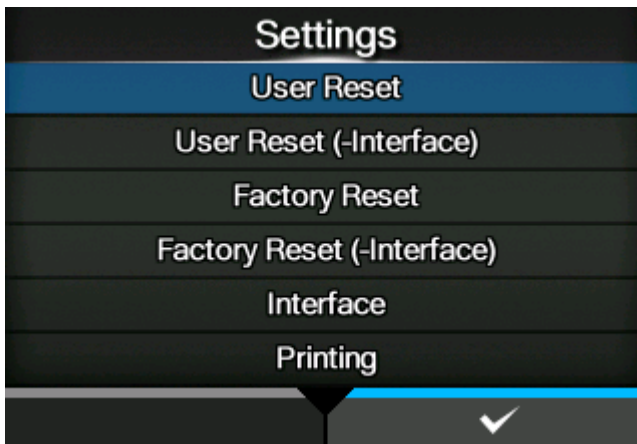

**[User Reset]**

Initialize the setting values.

**[User Reset (-Interface)]**

Initialize the setting values, except the interface settings.

**[Factory Reset]**

Initialize to the factory default settings.

**[Factory Reset (-Interface)]**

Initialize the setting items, except the interface settings, to the factory default settings.

**[Interface]**

Initialize the setting values for the interface settings.

**[Printing]**

Initialize the setting values in the [Printing] menu.

7. Press the  button to initialize.

Press the  button to cancel the initialization.

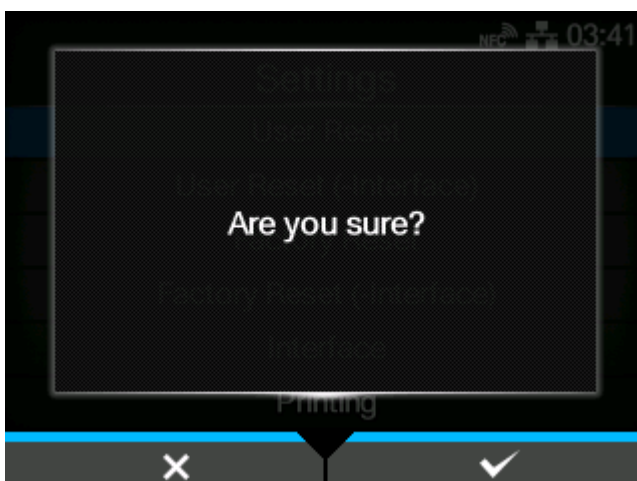

The initialization is performed.

Depending on the reset items you selected, the product restarts when the initialization is complete.

## List of Initial Values

### [Printing] Menu

Initial values refer to the values set for the product when it was shipped from the factory. If you reset the product, the values set in the product are initialized. The table below shows the initial value of each setting item and whether it would be initialized.



- Normally, it is not necessary to perform the initialization. Doing an initialization removes all the product's settings that the customer changed.

Setting Item	Initial Value		Initialized by User Reset/ Factory Reset
	S84NX	S86NX	
[Label Length]	<b>203 dpi</b> 20000 dots <b>305 dpi</b> 18000 dots <b>609 dpi</b> 9600 dots	<b>203 dpi</b> 20000 dots <b>305 dpi</b> 18000 dots	Yes/Yes
[Label Width]	<b>203 dpi</b> 832 dots <b>305 dpi</b> 1248 dots <b>609 dpi</b> 2496 dots	<b>203 dpi</b> 1340 dots <b>305 dpi</b> 2010 dots	Yes/Yes
[Auto Measure]	[Disabled]		Yes/Yes
[Printing Mode]	[Use Ribbon]		Yes/Yes
[Ribbon Near End]	[Enabled]		Yes/Yes
[Speed]	<b>203 dpi</b> 6 ips <b>305 dpi</b> 6 ips <b>609 dpi</b> 3 ips	<b>203 dpi</b> 6 ips <b>305 dpi</b> 6 ips	Yes/Yes
[Sensor Type]	[Gap]		Yes/Yes

Setting Item	Initial Value		Initialized by User Reset/ Factory Reset	
	S84NX	S86NX		
	[None] (When [Print Mode] is [Linerless])			
[Micro Label Print Mode]				
	[Micro Label Print Mode]	[Disabled]	Yes/Yes	
	[Auto Label Length Detection]	[Enabled]	Yes/Yes	
	[Label Length Averaging Count]	3	Yes/Yes	
	[Label Length]	<b>203 dpi</b> 320 dots <b>305 dpi</b> 480 dots <b>609 dpi</b> 960 dots	<b>203 dpi</b> 320 dots <b>305 dpi</b> 480 dots	Yes/Yes
	[Print Mode]	[Dispenser]	Yes/Yes	
	[Backfeed]	Before (If [Print Mode] is set to [Dispenser], [Dispense & Print] or [Linerless]) None (If [Print Mode] is set to [Continuous])	Yes/Yes	
	[Darkness]	6	Yes/Yes	
[Imaging]				
	[Vertical]	0 dot	Yes/Yes	
	[Horizontal]	0 dot	Yes/Yes	
[Advanced]				
	[Calibrate]			
	[Auto-calibration]	[Gap + I-Mark]	-	
	[GAP Levels]	Value adjusted by the factory	No/No	
	[GAP Slice Level]	Auto	No/No	
	[I-Mark Levels]	Value adjusted by the factory	No/No	
	[I-Mark Slice Level]	Auto	No/No	
	[Head Check]	[Off]	Yes/Yes	

Setting Item		Initial Value		Initialized by User Reset/ Factory Reset
		S84NX	S86NX	
	[Head Check Mode]	[Always]		Yes/Yes
	[Every Page]	1		Yes/Yes
	[Check Media Size]	[Disabled]		Yes/Yes
[Adjustments]				
	[Offset]	0 dot		No/No
	[Pitch]	0 dot		No/No
	[Pitch Offset]	0 dot		No/No
	[Darkness Adjust]	50		No/No
	[Start Online]	[Enabled]		Yes/Yes
	[Feed After Error]	[Disabled]		Yes/Yes
	[Feed At Power On]	[Disabled]		Yes/Yes
	[Finisher Feed]	0 dot ([Standard])		Yes/Yes
[Feed Speed]				
	[Sync with Print Speed]	[Enabled]		Yes/Yes
	[Feed Speed]	6 ips		Yes/Yes
	[Backfeed Speed]	6 ips		Yes/Yes
	[Paper End]	-		Yes/Yes
	[Sensor Type]	[Using I-mark]		Yes/Yes
	[Paper End Distance]	<b>203 dpi</b> 120 dots <b>305 dpi</b> 180 dots <b>609 dpi</b> 360 dots		Yes/Yes
	[Head Base Position]	[Standard]		Yes/Yes
	[Prioritize]	[Commands]		Yes/Yes
	[Reprint]	[Disabled]		Yes/Yes
	[Print End Position]	0 dot		Yes/Yes



Setting Item	Initial Value		Initialized by User Reset/ Factory Reset
	S84NX	S86NX	
<a href="#">[Calendar Setting Mode]</a> * For the items below this menu, refer to the table that follows.			
[Ribbon Tension Adjustment]	203 dpi 12 305 dpi 5 609 dpi 1		Yes/Yes
[Printing Operations]			
[Throughput Mode]	[Disabled]		Yes/Yes
[Extended Backfeed Operation]	[Disabled]		Yes/Yes
[Page Clipping Mode]	[Disabled]		Yes/Yes
[Feed Offset]	0 dot		Yes/Yes
[Backfeed Offset]	0 dot		Yes/Yes

- **[Calendar Setting Mode]**

Setting Item	Initial Value		Initialized by User Reset/ Factory Reset
	S84NX	S86NX	
[Calendar Reprint]	[Enabled]		Yes/Yes
[Day of Week Code]			
[Sunday]	1		Yes/Yes
[Monday]	2		Yes/Yes
[Tuesday]	3		Yes/Yes
[Wednesday]	4		Yes/Yes
[Thursday]	5		Yes/Yes
[Friday]	6		Yes/Yes
[Saturday]	7		Yes/Yes
[Month Code]			

Setting Item		Initial Value		Initialized by User Reset/ Factory Reset
		S84NX	S86NX	
	[January]	A		Yes/Yes
	[February]	B		Yes/Yes
	[March]	C		Yes/Yes
	[April]	D		Yes/Yes
	[May]	E		Yes/Yes
	[June]	F		Yes/Yes
	[July]	G		Yes/Yes
	[August]	H		Yes/Yes
	[September]	J		Yes/Yes
	[October]	K		Yes/Yes
	[November]	L		Yes/Yes
	[December]	M		Yes/Yes
[Case Format]		[Mixed]		Yes/Yes
[Calendar Check]		[Enabled]		Yes/Yes
[Work Shift Setting Mode]				Yes/Yes
1				
	[Shift Code]	[Disabled]		Yes/Yes
	[Shift Time]	00:00		Yes/Yes
	[Shift Name]	-		Yes/Yes
2				
	[Shift Code]	[Disabled]		Yes/Yes
	[Shift Time]	00:00		Yes/Yes
	[Shift Name]	-		Yes/Yes
3				
	[Shift Code]	[Disabled]		Yes/Yes
	[Shift Time]	00:00		Yes/Yes

Setting Item	Initial Value		Initialized by User Reset/ Factory Reset
	S84NX	S86NX	
[Shift Name]	-		Yes/Yes

## [Interface] Menu

Initial values refer to the values set for the product when it was shipped from the factory. If you reset the product, the values set in the product are initialized. The table below shows the initial value of each setting item and whether it would be initialized.

- [\[Network\]](#) > [\[Settings\]](#)
- [\[Network\]](#) > [\[Services\]](#) > [\[Ports\]/\[NTP\]/\[LPD\]/\[FTP\]/\[SNMP\]](#)
- [\[Network\]](#) > [\[Services\]](#) > [\[Online Services\]](#)
- [\[Network\]](#) > [\[Advanced\]](#)
- [\[RS-232C\]/\[USB\]/\[NFC\]/\[Ignore CR/LF\]/\[Ignore CAN/DLE\]](#)
- [\[External I/O\]](#)
- [\[RFID\]](#)



- Normally, it is not necessary to perform the initialization. Doing an initialization removes all the product's settings that the customer changed.

- **[Network]** > **[Settings]**

Setting Item	Initial Value		Initialized by User Reset/ Factory Reset
	S84NX	S86NX	
[LAN]			
[IPv4]			
[Mode]	[DHCP]		Yes/Yes
[DHCP]	-		-
[IP Address]	0.0.0.0		Yes/Yes
[Netmask]	255.255.255.0		Yes/Yes
[Gateway]	0.0.0.0		Yes/Yes
[DNS]	0.0.0.0, 0.0.0.0, 0.0.0.0		Yes/Yes
[IPv6]			
[Mode]	[Disable]		Yes/Yes
[DHCP]	-		-

Setting Item		Initial Value		Initialized by User Reset/ Factory Reset
		S84NX	S86NX	
	[IP Address]	::		Yes/Yes
	[Prefix Length]	64		Yes/Yes
	[Gateway]	::		Yes/Yes
	[DNS]	::		Yes/Yes
[Proxy]				
	[Enabled]	[Disabled]		Yes/Yes
	[Server]	-		Yes/Yes
	[Port No.]	-		Yes/Yes
	[Username]	-		Yes/Yes
	[Password]	-		Yes/Yes
	[Exclude]	-		Yes/Yes
[DHCP Options]				
	[Update DNS (Option 81)]	[Disabled]		Yes/Yes
	[Hostname]	sato-lan-serial number		Yes/Yes
[Wi-Fi]				
[IPv4]				
	[Mode]	[DHCP]		Yes/Yes
	[DHCP]	-		-
	[IP Address]	0.0.0.0		Yes/Yes
	[Netmask]	255.255.255.0		Yes/Yes
	[Gateway]	0.0.0.0		Yes/Yes
	[DNS]	0.0.0.0, 0.0.0.0, 0.0.0.0		Yes/Yes
[IPv6]				
	[Mode]	[Disable]		Yes/Yes
	[DHCP]	-		-
	[IP Address]	::		Yes/Yes
	[Prefix Length]	64		Yes/Yes

Setting Item	Initial Value		Initialized by User Reset/ Factory Reset
	S84NX	S86NX	
[Gateway]	::		Yes/Yes
[DNS]	::		Yes/Yes
[Proxy]			
[Enabled]	[Disabled]		Yes/Yes
[Server]	-		Yes/Yes
[Port No.]	-		Yes/Yes
[Username]	-		Yes/Yes
[Password]	-		Yes/Yes
[Exclude]	-		Yes/Yes
[DHCP Options]			
[Update DNS (Option 81)]	[Disabled]		Yes/Yes
[Hostname]	sato-wlan-serial number		Yes/Yes
[Wi-Fi Protected Setup]	-		-
[Wi-Fi Direct]			
[Device Name]	SATO_PRINTER		Yes/Yes
[Band]	[All]		Yes/Yes
[SSID]	SATO_PRINTER		Yes/Yes
[Hidden SSID]	[Enabled]		Yes/Yes
[Mode]	[Ad-hoc]		Yes/Yes
[Channel]	6		Yes/Yes
[Security]	[None]		Yes/Yes
[WEP Conf.]			
[Authentication]	[Open System]		Yes/Yes
[Key Index]	1		Yes/Yes
[Key #1] to [Key #4]	-		Yes/Yes
[WPA Conf.]			
[WPA Authentication]	[Personal (PSK)]		Yes/Yes

Setting Item	Initial Value		Initialized by User Reset/ Factory Reset
	S84NX	S86NX	
[PSK]	-	-	Yes/Yes
[EAP Conf.]			
[EAP Mode]	[FAST]	-	Yes/Yes
[Inner Method]	[AUTO]	-	Yes/Yes
[Username]	-	-	Yes/Yes
[Password]	-	-	Yes/Yes
[Anon. Outer ID]	-	-	Yes/Yes
[Verify Server Cert.]	[Enabled]	-	Yes/Yes
[Private Key P/W]	-	-	Yes/Yes
[PAC Auto Provisioning]	[Disabled]	-	Yes/Yes
[PAC P/W]	-	-	Yes/Yes
[Interface]	[Auto]	-	Yes/Yes

- [Network] > [Services] > [Ports]/[NTP]/[LPD]/[FTP]/[SNMP]

Setting Item	Initial Value		Initialized by User Reset/ Factory Reset
	S84NX	S86NX	
[Ports]			
[Port1]	1024	-	Yes/Yes
[Port2]	1025	-	Yes/Yes
[Port3]	9100	-	Yes/Yes
[Flow Control]	[Status4 ENQ]	-	Yes/Yes
[TCP Connection Queue]	[Enabled]	-	Yes/Yes
[Legacy Status for Port 9100]	[Disabled]	-	Yes/Yes
[ENQ Reply Delay]	0 ms	-	Yes/Yes
[Status4 Cyclic Response]	500 ms	-	Yes/Yes
[BCC]	[Disabled]	-	Yes/Yes
[NTP]			

Setting Item		Initial Value		Initialized by User Reset/ Factory Reset
		S84NX	S86NX	
	[Enable]	[Disabled]		No/Yes <sup>1</sup>
	[Error]	[Disabled]		Yes/Yes
	[Time Server IP]	0.0.0.0		Yes/Yes
[LPD]				
	[Enable]	[Enabled]		Yes/Yes
	[DNS Lookup]	[Disabled]		Yes/Yes
[FTP]				
	[Enable]	[Disabled]		Yes/Yes
	[FTP Timeout]	300 seconds		Yes/Yes
[SNMP]				
	[sysContact]	-		Yes/Yes
	[sysName]	-		Yes/Yes
	[sysLocation]	-		Yes/Yes
	[prtMarkerCounterUnit]	[meters]		Yes/Yes
[Agent]				
	[Enable]	[Enabled]		Yes/Yes
[Read-Only]				
	[SNMP Version]	[1 2c 3]		Yes/Yes
	[Community]	public		Yes/Yes
	[User]	rouser		Yes/Yes
	[User Security]	[None]		Yes/Yes
	[Authentication Protocol]	[MD5]		Yes/Yes
	[Authentication Passphrase]	mypassword		Yes/Yes
	[Privacy Protocol]	[DES]		Yes/Yes
	[Privacy Passphrase]	mypassword		Yes/Yes
[Read-Write]				
	[SNMP Version]	[Disabled]		Yes/Yes

Setting Item			Initial Value		Initialized by User Reset/ Factory Reset
			S84NX	S86NX	
		[Community]	private		Yes/Yes
		[User]	rwuser		Yes/Yes
		[User Security]	[None]		Yes/Yes
		[Authentication Protocol]	[MD5]		Yes/Yes
		[Authentication Passphrase]	mypassword		Yes/Yes
		[Privacy Protocol]	[DES]		Yes/Yes
		[Privacy Passphrase]	mypassword		Yes/Yes
[Traps]					
		[Enable]	[Disabled]		Yes/Yes
		[SNMP Version]	1		Yes/Yes
		[IP Version]	4		Yes/Yes
		[Destinations]	1		Yes/Yes
		[Destination 1]	0.0.0.0		Yes/Yes
		[Destination 2]	0.0.0.0		Yes/Yes
		[Destination 3]	0.0.0.0		Yes/Yes
		[Community]	trapcom		Yes/Yes
		[User]	trapuser		Yes/Yes
		[Engine ID]	Hex string generated from MAC address		Yes/Yes
		[Security]	[None]		Yes/Yes
		[Authentication Protocol]	[MD5]		Yes/Yes
		[Authentication Passphrase]	mypassword		Yes/Yes
		[Privacy Protocol]	[DES]		Yes/Yes
		[Privacy Passphrase]	mypassword		Yes/Yes

- [Network] > [Services] > [Online Services]



Setting Item	Initial Value		Initialized by User Reset/ Factory Reset
	S84NX	S86NX	
[SOS Mode]	[Disabled]		No/No
[Allow Remote Control]	[Always]		No/No
[MQTT Protocol]	[MQTT over WebSocket]		No/No
[MQTT Proxy enabled]	[Enabled]		No/No
[Add Device]	-		-
[Contact Information]			
[Phone Number]	-		-
[Periodic Notification]			
[Type]	[Disabled]		No/No
[Counter]	[Head]		No/No
[Head]	10000		No/No
[Notifications]	1		No/No
[Time 1]	00:00		No/No
[Time 2]	00:00		No/No
[Time 3]	00:00		No/No
[Weekday]	[Monday]		No/No
[Day]	1		No/No
[Time]	00:00		No/No
[Update Screen]	[Normal]		No/No
[QR code offset]			
[Vertical]	0 dot		No/No
[Horizontal]	0 dot		No/No
[Daily Checkup]	-		-
[Port diagnostic]	-		-

- [Network] > [Advanced]

Setting Item	Initial Value		Initialized by User Reset/ Factory Reset
	S84NX	S86NX	
[ARP Announcement]			
[Additional]	[Enabled]		Yes/Yes
[Periodic]	0 sec		Yes/Yes
[Firewall]			
[Enable]	[Disabled]		Yes/Yes
[Allow Services And Ports]			
[Data Ports]	[Enabled]		Yes/Yes
[FTP]	[Disabled]		Yes/Yes
[LPD]	[Enabled]		Yes/Yes
[MAILC]	[Enabled]		Yes/Yes
[NTP]	[Disabled]		No/Yes <sup>1</sup>
[Online Services]	[Disabled]		No/No
[PING]	[Enabled]		Yes/Yes
[SATO All-In-One Tool]	[Enabled]		Yes/Yes
[SCP]	[Enabled]		Yes/Yes
[SNMP Agent]	[Enabled]		Yes/Yes
[WEBC]	[Enabled]		Yes/Yes
[WebConfig]	[Enabled]		Yes/Yes
[Custom Settings]			
[TCP Source Port]			
[Existing Port No.]	22 80 443 465 587 8080		-
[Additional Port No.]	-		Yes/Yes
[TCP Destination Port]			
[Existing Port No.]	80 443 515 1024 1025 9100		-
[Additional Port No.]	-		Yes/Yes

Setting Item	Initial Value		Initialized by User Reset/ Factory Reset
	S84NX	S86NX	
[UDP Source Port]			
[Existing Port No.]	53		-
[Additional Port No.]	-		Yes/Yes
[UDP Destination Port]			
[Existing Port No.]	161 19541		-
[Additional Port No.]	-		Yes/Yes
[ICMP Type]			
[Existing ICMP Type]	0 8		-
[Additional ICMP Type]	-		Yes/Yes

- **[RS-232C]/[USB]/[NFC]/[Ignore CR/LF]/[Ignore CAN/DLE]**

Setting Item	Initial Value		Initialized by User Reset/ Factory Reset
	S84NX	S86NX	
[RS-232C]			
[Baudrate]	[115200]		Yes/Yes
[Parameters]	[8-N-1]		Yes/Yes
[Flow Control]	[STATUS4]		Yes/Yes
[BCC]	[Disabled]		Yes/Yes
[USB]			
[Flow Control]	[Status4]		Yes/Yes
[BCC]	[Disabled]		Yes/Yes
[Change USB Serial]	[Disabled]		No/Yes
[NFC]			
[I/F Enable]	[Enabled]		Yes/Yes
[Ignore CR/LF]	[Disabled]		Yes/Yes

Setting Item	Initial Value		Initialized by User Reset/ Factory Reset
	S84NX	S86NX	
[Ignore CAN/DLE]	[Disabled]		Yes/Yes

- [External I/O]

Setting Item	Initial Value		Initialized by User Reset/ Factory Reset
	S84NX	S86NX	
[External I/O]			
[Print Start Signal]			
[Enable]	[Enabled]		Yes/Yes
[PIN]	[PIN20]		Yes/Yes
[Signal State]	[Active Low]		Yes/Yes
[EXT I/O Re-print]			
[Enable]	[Disabled]		Yes/Yes
[PIN]	[PIN8]		Yes/Yes
[Signal State]	[Active Low]		Yes/Yes
[Continuous Print]	[Disabled]		Yes/Yes
[Enhanced Reprint]	[Disabled]		Yes/Yes
[Signals]			
[Inputs]			
[PIN7]			
[Function]	[Label Near End]		Yes/Yes
[Signal State]	[Active Low]		Yes/Yes
[PIN9]			
[Function]	[Dispense In]		Yes/Yes
[Signal State]	[Falling Edge]		Yes/Yes
[PIN10]			

Setting Item				Initial Value		Initialized by User Reset/ Factory Reset
				S84NX	S86NX	
			[Function]	[Unassigned]		Yes/Yes
			[Signal State]	-		Yes/Yes
			[PIN21]			
			[Function]	[Feed]		Yes/Yes
			[Signal State]	[Active Low]		Yes/Yes
			[PIN22]			
			[Function]	[Unassigned]		Yes/Yes
			[Signal State]	-		Yes/Yes
			[PIN23]			
			[Function]	[Unassigned]		Yes/Yes
			[Signal State]	-		Yes/Yes
			[Outputs]			
			[PIN3]			
			[Function]	[Home Position]		Yes/Yes
			[Signal State]	[Active Low]		Yes/Yes
			[PIN4]			
			[Function]	[Machine Error] S84NX RFID models: [Machine Error/ RFID Error]		Yes/Yes
			[Signal State]	[Active Low]		Yes/Yes
			[PIN5]			
			[Function]	[Print Done]		Yes/Yes
			[Signal State]	[TYPE4]		Yes/Yes
			[PIN6]			
			[Function]	[Print Ready]		Yes/Yes

Setting Item				Initial Value		Initialized by User Reset/ Factory Reset
				S84NX	S86NX	
			[Signal State]	[Active High]		Yes/Yes
			[PIN16]			
			[Function]	[Ribbon End] S84NX RFID models: [RFID Tag Error]		Yes/Yes
			[Signal State]	[Active Low]		Yes/Yes
			[PIN17]			
			[Function]	[Paper End] S84NX RFID models: [Paper End/Ribbon End]		Yes/Yes
			[Signal State]	[Active Low]		Yes/Yes
			[PIN18]			
			[Function]	[Ribbon Near End]		Yes/Yes
			[Signal State]	[Active High]		Yes/Yes
			[PIN19]			
			[Function]	[Unassigned]		Yes/Yes
			[Signal State]	-		Yes/Yes

- [RFID]

Setting Item	Initial Value	Initialized by User Reset/ Factory Reset
[Antenna Position]	[Normal]	Yes/Yes
[Write Power]	15 dBm	Yes/Yes
[Read Power]	15 dBm	Yes/Yes
[Tag Offset]	0 mm	Yes/Yes

Setting Item		Initial Value	Initialized by User Reset/ Factory Reset
[Reader Model]		-	-
[Reader Version]		-	-
[View]			
	[Memory Bank]	[EPC]	Yes/Yes
	[Data Reading]	-	-
[Filter Function]			
	[RSSI Filter]	[Disabled]	Yes/Yes
	[Threshold Value]	-50 dBm	Yes/Yes
[Retry Mode]		[Retry]	Yes/Yes
[Retries]		1	Yes/Yes
[Mark bad tags]		[Enabled]	Yes/Yes
[RFID Undetected Warning]		[Disable]	Yes/Yes
[Log RFID Data]		[Disabled]	Yes/Yes
[Data To Record]		[EPC and TID]	Yes/Yes
[Output Error Mode]		[Level]	Yes/Yes
[Pulse Length]		[100 ms]	Yes/Yes
[Counters]			
	[Life]		
	[Count Success]	0	No/Yes <sup>1</sup>
	[Count Failure]	0	No/Yes <sup>1</sup>
	[Count Total]	0	No/Yes <sup>1</sup>
	[User]		
	[Count Success]	0	Yes/Yes <sup>2</sup>
	[Count Failure]	0	Yes/Yes <sup>2</sup>
	[Count Total]	0	Yes/Yes <sup>2</sup>
[Paper]			

Setting Item		Initial Value	Initialized by User Reset/ Factory Reset
	[Types]	[Label]	Yes/Yes
	[Starting Point]	0 dot	Yes/Yes
[RFID Tag Model]			
	[Load]	-Undefined-	Yes/Yes
	[Edit]		
	[Antenna Position]	[Normal]	Yes/Yes
	[Write Power]	15 dBm	Yes/Yes
	[Read Power]	15 dBm	Yes/Yes
	[Tag Offset]	0 mm	Yes/Yes
	[Pitch Size]	<b>203 dpi</b> 8 dots <b>305 dpi</b> 12 dots <b>609 dpi</b> 24 dots	Yes/Yes
	[Save as]	RFID_TAG	Yes/Yes
	[Delete]	-	-

<sup>1</sup> Can also be initialized by [Factory Reset (-Interface)]

<sup>2</sup> Can also be initialized by [User Reset (-Interface)]/[Factory Reset (-Interface)]

## [Applications] Menu

Initial values refer to the values set for the product when it was shipped from the factory. If you reset the product, the values set in the product are initialized. The table below shows the initial value of each setting item and whether it would be initialized.

- [\[Protocol\]/\[Auto Switch Group\]/\[SBPL\]](#)
- [\[SZPL\]/\[SIPL\]](#)
- [\[SDPL\]/\[AEP\]](#)



- Normally, it is not necessary to perform the initialization. Doing an initialization removes all the product's settings that the customer changed.



- **[Protocol]/[Auto Switch Group]/[SBPL]**

Setting Item		Initial Value		Initialized by User Reset/ Factory Reset
		S84NX	S86NX	
[Protocol]		[AUTO]		Yes/Yes
[Auto Switch Group]				
	[SBPL]	[Enabled]		Yes/Yes
	[SZPL]	[Enabled]		Yes/Yes
	[SIPL]	[Enabled]		Yes/Yes
	[SDPL]	[Enabled]		Yes/Yes
[SBPL]				
	[Show Error]	[Disabled] S84NX RFID models: [Enabled]		Yes/Yes
	[Standard Code]	[Enabled]		Yes/Yes
	[Orientation]	[Portrait]		Yes/Yes
[Font Settings]				
	[Zero Slash]	[Enabled]		Yes/Yes
[Kanji]				
	[Kanji Set]	[GB18030]		Yes/Yes
	[Character Code]	[GB18030]		Yes/Yes
	[Kanji Style]	[Gothic]		Yes/Yes
	[Proportional]	[Enabled]		Yes/Yes
	[Code Page]	858		Yes/Yes
	[€]	d5		Yes/Yes
[Compatible]				
	[M-8400 Compatibility]	[Disabled]		Yes/Yes
	[CODE128(C) Zero Fill]	[Disabled]		Yes/Yes
	[Kanji Command]	[Disabled]		Yes/Yes
	[Call Font/Logo]	[Disabled]		Yes/Yes

Setting Item	Initial Value		Initialized by User Reset/ Factory Reset
	S84NX	S86NX	
[A3 Command Save(S-type)]	[Enabled]		Yes/Yes
[PDF417 ECC Level fixed]	[Disabled]		Yes/Yes
[Head Size]	-	[Normal]	Yes/Yes
[Darkness]	[Disabled]		Yes/Yes

• [SZPL]/[SIPL]

Setting Item	Initial Value		Initialized by User Reset/ Factory Reset
	S84NX	S86NX	
[SZPL]			
[Label]			
[Shift]	0 dot		Yes/Yes
[Top]	0 dot		Yes/Yes
[Label Rotation]	[0 degree]		Yes/Yes
[Caret]	94 (^)		Yes/Yes
[Delimiter]	44 (,)		Yes/Yes
[Tilde]	126 (~)		Yes/Yes
[Clock Format]	[(none)]		Yes/Yes
[Default Font]	[(none)]		Yes/Yes
[SIPL]			
[Font Settings]			
[Code Page]	1252		Yes/Yes
[New Font Encoding]	[Disabled]		Yes/Yes
[c20 Proportional Pitch]	[Disabled]		Yes/Yes
[Zero Slash]	[Disabled]		Yes/Yes
[Format Save]	[Enabled]		Yes/Yes

- [SDPL]/[AEP]

Setting Item	Initial Value		Initialized by User Reset/ Factory Reset
	S84NX	S86NX	
[SDPL]			
	[Control Code]		
	[Code Type]	[Standard]	Yes/Yes
	[SOH]	01	Yes/Yes
	[STX]	02	Yes/Yes
	[CR]	0D	Yes/Yes
	[CNTBY]	5E	Yes/Yes
	[Label Rotation]	[0 degree]	Yes/Yes
	[SOP Emulation]	[Auto]	Yes/Yes
[Compatible Mode]			
	[TTF]	[Disabled]	Yes/Yes
	[Graphics]	[Disabled]	Yes/Yes
	[Compression]	[Disabled]	Yes/Yes
	[Right-to-Left print]	[Auto]	Yes/Yes
	[Receive TimeOut]	0 (Off)	Yes/Yes
	[Blank Item Feed]	[Enabled]	Yes/Yes
[Prioritize]			
	[Format Attribute]	[Commands]	Yes/Yes
	[Pause Mode]	[Commands]	Yes/Yes
	[1 Byte Codepage]	[Commands]	Yes/Yes
	[SDPL Measure Unit]	[Commands]	Yes/Yes
	[Scalable Font Style]	[Commands]	Yes/Yes
	[Sensor Type]	[Commands]	Yes/Yes
	[Feedback Character]	[Commands]	Yes/Yes

Setting Item		Initial Value		Initialized by User Reset/ Factory Reset
		S84NX	S86NX	
	[SOH Commands]	[Commands]		Yes/Yes
	[Module Selection]	[Commands]		Yes/Yes
	[Darkness]	-		Yes/Yes
	[Factory Offset]	-		Yes/Yes
	[Speed]	-		Yes/Yes
	[Format Attribute]	[XOR]		Yes/Yes
	[Pause Mode]	[Disabled]		Yes/Yes
	[1 Byte Codepage]	[CP 850]		Yes/Yes
	[SDPL Measure Unit]	[Inch]		Yes/Yes
	[Scalable Font Style]			
	[Bold]	[Disabled]		Yes/Yes
	[Italic]	[Disabled]		Yes/Yes
	[Feedback Character]	[Enabled]		Yes/Yes
	[SOH Commands]			
	[All Commands]	[Enabled]		Yes/Yes
	[SOH-B Command]	[Enabled]		Yes/Yes
	[SOH-C Command]	[Enabled]		Yes/Yes
	[Others]	[Enabled]		Yes/Yes
	[Module Selection]	A		Yes/Yes
	[AEP]			
	[Enable]	[Disabled]		No/Yes
	[Starting Application]	[Simple Standalone]		No/Yes
	[Delete Application]	-		-
	[Label Rotation]	[Disabled]		Yes/Yes

## [System] Menu

Initial values refer to the values set for the product when it was shipped from the factory. If you reset the product, the values set in the product are initialized. The table below shows the initial value of each setting item and whether it would be initialized.



- Normally, it is not necessary to perform the initialization. Doing an initialization removes all the product's settings that the customer changed.

Setting Item	Initial Value		Initialized by User Reset/ Factory Reset
	S84NX	S86NX	
[Regional]			
[Messages]	[English, US]		Yes/Yes
[USB Keyboard]	[English, US]		Yes/Yes
[Locale]	[English, US]		Yes/Yes
[Unit]	[dot]		Yes/Yes
[Time]	00:00		No/No
[Date]	(2000-01-01)		No/No
[Time Zone]	-		Yes/Yes
[Region]	Europe		Yes/Yes
[City]	London		Yes/Yes
[Display Language Icon]	[Disabled]		Yes/Yes
[Notifications]			
[Clean Printhead]			
[Clean Printhead]	[Disabled]		Yes/Yes
[Cleaning Interval]	400 m		Yes/Yes
[Change Printhead]			
[Change Printhead]	[Disabled]		Yes/Yes
[Printhead Interval]	100 km		Yes/Yes
[Change Platen]			
[Change Platen]	[Disabled]		Yes/Yes
[Platen Interval]	100 km		Yes/Yes

Setting Item	Initial Value		Initialized by User Reset/ Factory Reset
	S84NX	S86NX	
[Change Belt(Gear Box)]			
[Change Belt]	[Disabled]		Yes/Yes
[Belt Interval]	150 km		Yes/Yes
[Change Belt(Ribbon)]			
[Change Belt]	[Disabled]		Yes/Yes
[Belt Interval]	150 km		Yes/Yes
[Sound]			
[Error Sound]	[Medium]		Yes/Yes
[LCD Brightness]	7		No/Yes
[LED Indication]	[Enabled]		Yes/Yes
[Cover Open Sensor]	[Enabled]		Yes/Yes
[Show Total Count]	[Disabled]		Yes/Yes
[Password]			
[Password Enable]	[Disabled]		No/Yes
[Install Security]	[Disabled]		No/Yes
[NFC Security]	[None]		Yes/Yes

## [Tools] Menu

Initial values refer to the values set for the product when it was shipped from the factory. If you reset the product, the values set in the product are initialized. The table below shows the initial value of each setting item and whether it would be initialized.



- Normally, it is not necessary to perform the initialization. Doing an initialization removes all the product's settings that the customer changed.

Setting Item	Initial Value		Initialized by User Reset/ Factory Reset
	S84NX	S86NX	
[Test Print]			
[Factory]			

Setting Item		Initial Value		Initialized by User Reset/ Factory Reset
		S84NX	S86NX	
	[Label Width]	[Large]		Yes/Yes
	[Pitch]	0 dot		No/No
	[Offset]	0 dot		No/No
	[Darkness Adjust]	50		No/No
[Configure List]				
	[Label Width]	[Small]		-
	[Label Length]	<b>203 dpi</b> 800 dots <b>305 dpi</b> 1200 dots <b>609 dpi</b> 2400 dots	<b>203 dpi</b> 800 dots <b>305 dpi</b> 1200 dots	Yes/Yes
	[Pitch]	0 dot		No/No
	[Offset]	0 dot		No/No
	[Darkness Adjust]	50		No/No
[Configure QR]				
	[Label Width]	[Small]		-
	[Label Length]	<b>203 dpi</b> 800 dots <b>305 dpi</b> 1200 dots <b>609 dpi</b> 2400 dots	<b>203 dpi</b> 800 dots <b>305 dpi</b> 1200 dots	Yes/Yes
	[Pitch]	0 dot		No/No
	[Offset]	0 dot		No/No
	[Darkness Adjust]	50		No/No
[Paper Sensor]				
	[Label Width]	[Small]		-

Setting Item		Initial Value		Initialized by User Reset/ Factory Reset
		S84NX	S86NX	
	[Label Length]	<b>203 dpi</b> 800 dots <b>305 dpi</b> 1200 dots <b>609 dpi</b> 2400 dots	<b>203 dpi</b> 800 dots <b>305 dpi</b> 1200 dots	Yes/Yes
	[Pitch]	0 dot		No/No
	[Offset]	0 dot		No/No
	[Darkness Adjust]	50		No/No
[Head Check]				
	[Label Width]	<b>203 dpi</b> 832 dots <b>305 dpi</b> 1248 dots <b>609 dpi</b> 2496 dots	<b>203 dpi</b> 1340 dots <b>305 dpi</b> 2010 dots	Yes/Yes
	[Label Length]	<b>203 dpi</b> 120 dots <b>305 dpi</b> 180 dots <b>609 dpi</b> 360 dots	<b>203 dpi</b> 120 dots <b>305 dpi</b> 180 dots	Yes/Yes
	[Pitch]	0 dot		No/No
	[Offset]	0 dot		No/No
	[Darkness Adjust]	50		No/No
[HEX-Dump]				
	[Hex Dump Mode]	[Disabled]		Yes/Yes
[Reset]				
[Profiles]				



Setting Item		Initial Value		Initialized by User Reset/ Factory Reset
		S84NX	S86NX	
	[Delete]	-		-
	[Load]	-		-
	[Save]	-		-
	[Start with]	-		Yes/Yes
[Certificates]		-		Yes/Yes
[Barcode Checker]				
	[Test]			
	[Reader Name]	-		-
	[Reading Test]	-		-
	[Interface]	[RS-232C]		Yes/Yes
[Settings]				
	[Mode]	[Disabled]		Yes/Yes
	[Set No. of Barcodes]	[Command]		Yes/Yes
	[Barcodes per Label]	1		Yes/Yes
	[Start Position]	<b>203 dpi</b> 72 dots <b>305 dpi</b> 108 dots <b>609 dpi</b> 216 dots	<b>203 dpi</b> 72 dots <b>305 dpi</b> 108 dots	Yes/Yes
	[VOID Print]	[Disabled]		Yes/Yes
	[Retry Count]	0		Yes/Yes
	[Host Notification]	[Disabled]		Yes/Yes
[Logs]				
	[Copy]	-		-
	[Remove]	-		-
[Clone]		[Excl. LAN/Wi-Fi/IP]		-

Setting Item	Initial Value		Initialized by User Reset/ Factory Reset
	S84NX	S86NX	
[Clone Notice Setting]	[Disabled]		Yes/Yes
[Support Info]	-		-
[Logging Function]			
[Enabled]	[Disabled]		Yes/Yes
[Save]	-		-
[Delete]	-		-
[Startup Guide]	[Enabled]		No/Yes

## [Information] Menu

Initial values refer to the values set for the product when it was shipped from the factory. If you reset the product, the values set in the product are initialized. The table below shows the initial value of each setting item and whether it would be initialized.



- Normally, it is not necessary to perform the initialization. Doing an initialization removes all the product's settings that the customer changed.

Setting Item	Initial Value		Initialized by User Reset/ Factory Reset
	S84NX	S86NX	
[Help]	-		-
[Build Version]	-		-
[Applications]	-		-
[Installation Log]	-		-
[Print Module]	-		-
[FPGA Version]	-		-
[Counters]			
[Head]			
[Life]	Measured value		No/No
[Head 1]	Measured value		No/Yes

Setting Item		Initial Value		Initialized by User Reset/ Factory Reset
		S84NX	S86NX	
	[Head 2]	Measured value		No/Yes
	[Head 3]	Measured value		No/Yes
	[Dispenser]	Measured value		No/Yes
	[Belt(Gear Box)]			
	[Belt 1]	Measured value		No/Yes
	[Belt 2]	Measured value		No/Yes
	[Belt 3]	Measured value		No/Yes
	[Belt(Ribbon)]			
	[Belt 1]	Measured value		No/Yes
	[Belt 2]	Measured value		No/Yes
	[Belt 3]	Measured value		No/Yes
	[IPv4 Address]	0.0.0.0		-
	[IPv6 Address]	0:0:0:0:0:0:0		-
	[LAN MAC]	-		-
	[Wi-Fi MAC]	-		-
	[Wi-Fi Region]	-		-
	[Wi-Fi Status]	-		-
	[Wi-Fi Direct]	-		-
	[Wi-Fi Versions]	-		-
	[Wi-Fi Module]	-		-
	[USB Serial]	-		-

---

# Maintenance

---

## Cleaning the Product

---

### Cleaning

A dirty print head or platen roller not only affects the print quality but also causes errors and malfunctions. Clean the product periodically to keep it running reliably.



- Do not power on or off the product, connect or disconnect the power cord while your hands are wet. Doing so could cause an electric shock.



- Disconnect the power cord from the AC outlet before you begin cleaning.  
The print head and its surroundings are hot after printing. Wait until the product cools down.
- Touching the edge of the print head with your bare hand could cause injury.
- Use our recommended cleaning products for cleaning. Do not clean with a hard object. Doing so could cause damage.
- Remove the media and ribbon before cleaning.



- Contact your SATO reseller or technical support to purchase the cleaning kit, cleaning sheets, and other of our cleaning products.
-

## Cleaning Intervals

Clean the product at the following regular intervals.



- The below cleaning intervals are only for reference. Clean the product when necessary even if you are not at a regular interval.
- 

- After you print one media roll or print media for 150 meters (492.1 feet).

Use the cleaning kit to clean following parts:

- Print head
- Platen roller
- Media sensors
- Media guide

- After you print six media rolls or print media for 900 meters (2952.8 feet).

Use the cleaning sheet to clean the following parts:

- Print head
- Platen roller

Use the cleaning kit to clean following parts:

- Media route
- Ribbon route
- Media guide
- Feed roller

## Cleaning Using the Cleaning Kit

The cleaning procedure using the cleaning kit is as follows:



- Never use organic solvents, such as thinner and benzene to clean the product.
- 



- For details on the cleaning kit, refer to the manual attached to the cleaning kit.
- 

**1. Make sure that the product is powered off, and disconnect the power cord from the AC outlet.**

**2. Open the top cover.**



- Open the top cover fully to prevent accidental drop of the cover.
- 

**3. Turn the head lock lever (1) clockwise to unlock the print head.**



- The print head and its surroundings are hot after printing. Be careful not to get burned.
  - Touching the edge of the print head with your bare hand could cause injury.
- 

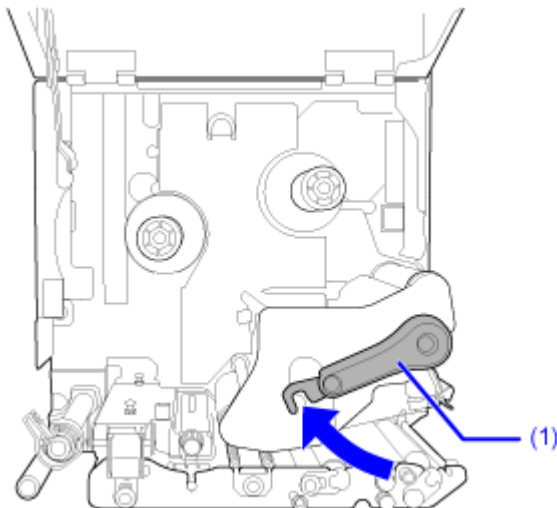

**4. Pull the feed lock latch (2) to unlock the feed roller and media sensor assembly (3).**

The feed roller and media sensor assembly (3) flipped open.

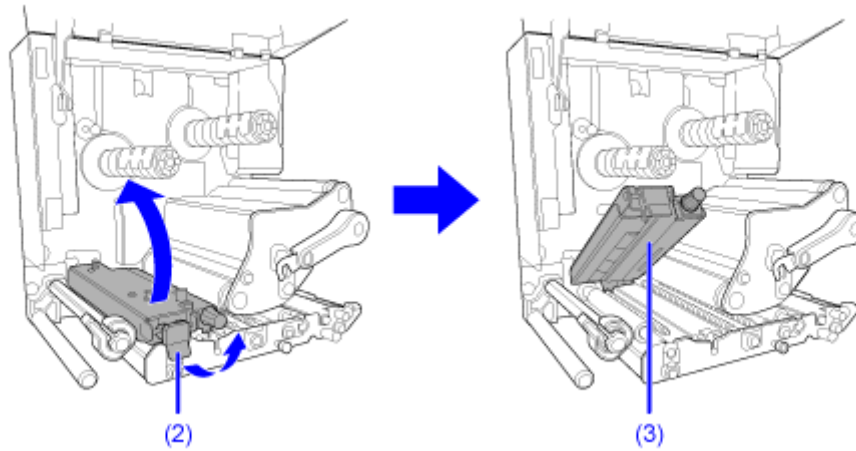

**5. Pull the media guide (4) away from the product.**

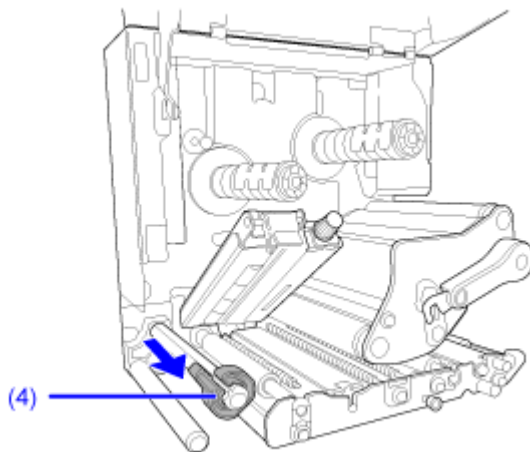

**6. Remove the media and ribbon if they are already loaded.**

7. Clean the dirt on the print head (5), ribbon roller (6), platen roller (7) and pressure roller (8) using a cotton swab/cloth dabbed with cleaning liquid.

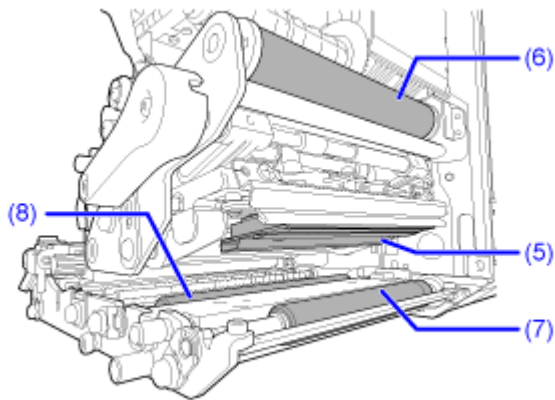

8. Clean the dirt on the pressure plate (9) using the cotton cloth dabbed with cleaning liquid.

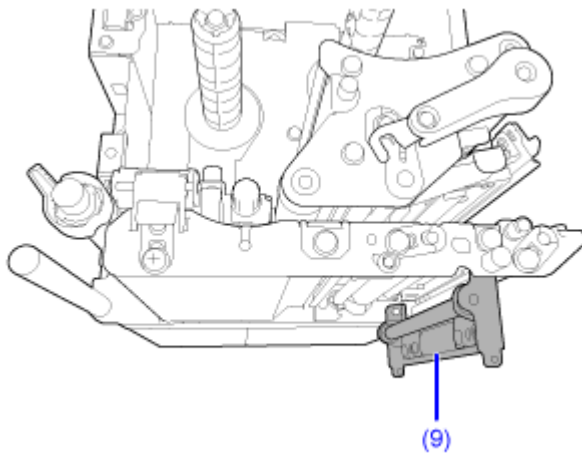

You can remove the pressure plate to clean it easily.



- a. Push the tab (10) up to release the pressure plate (9).

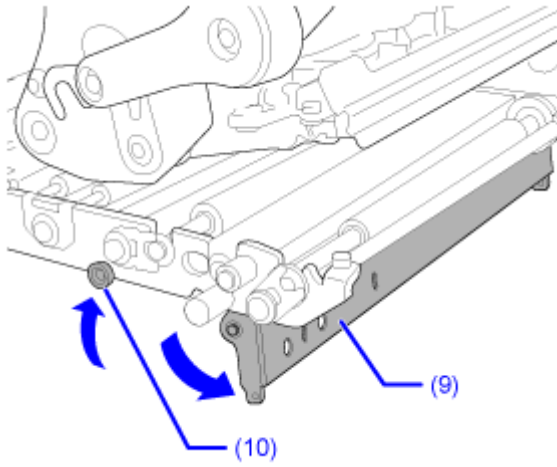

- b. While supporting the pressure plate (9), loosen screw (11) until the front of the plate falls **1**, and then pull the pressure plate (9) forward to remove it **2**.

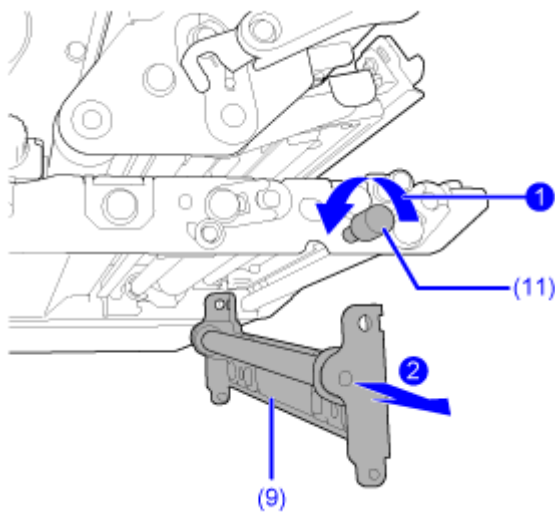

- c. To assemble the pressure plate (9), insert the protrusion of the product's center frame securely into the mounting hole on the leading-edge side of the pressure plate (9).

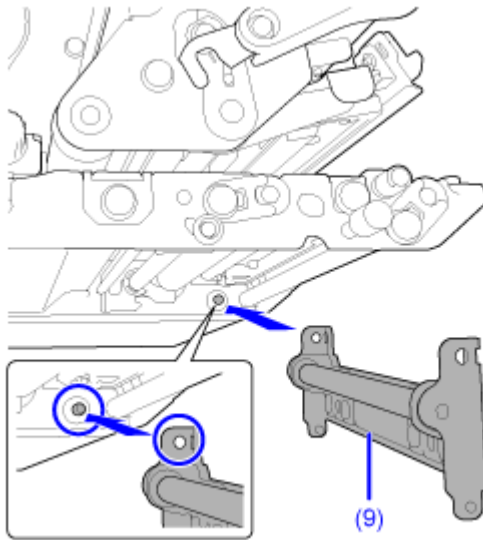

- d. Align the position of the screw (11) to the mounting hole on the front side of the pressure plate (9) **1**, and tighten them **2**.

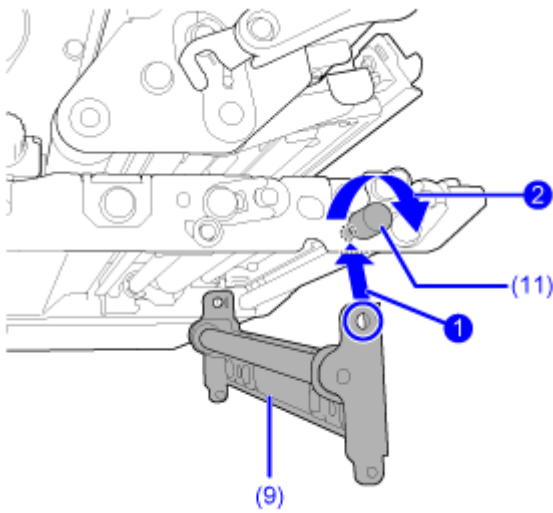

- e. Push the center of the pressure plate (9) to latch it in place.

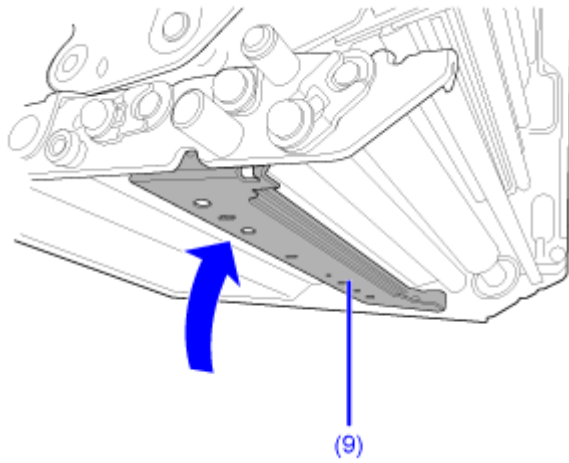

9. Clean the dirt on the media shafts (12), feed roller (13), media sensor (14) and ribbon roller (15) using the cotton swab/cloth dabbed with cleaning liquid.

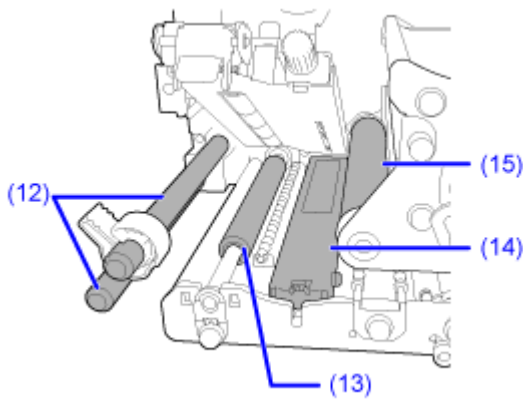

10. Clean the bottom of the feed roller and media sensor assembly (3) using the cotton cloth dabbed with cleaning liquid.

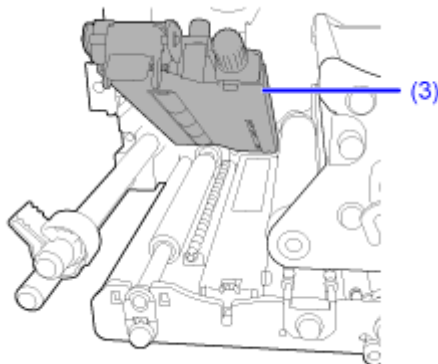

You can remove the media sensor cover to clean the surface easily.

- a. Loosen the thumbscrew (16) attached to the media sensor cover (17) ①, and remove the media sensor cover (17) ②.

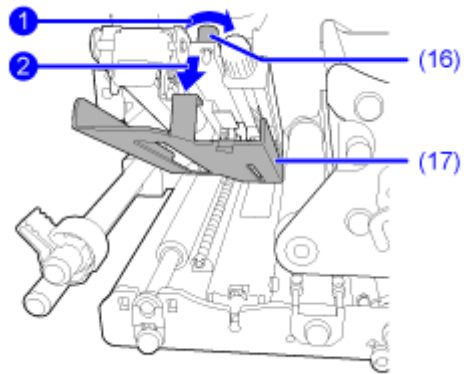

- b. To assemble the media sensor cover (17), insert the tab of the media sensor cover (17) into the slot as shown.

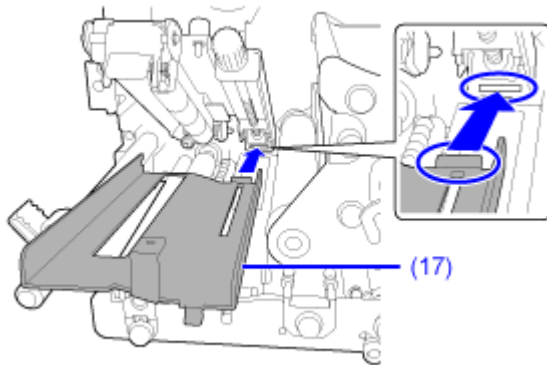

- c. Attach the media sensor cover (17) using the thumbscrew (16).

11. Turn the head lock lever (1) counterclockwise to lock the print head (1), and then press the feed roller and media sensor assembly (3) down until the feed lock latch (2) is locked (2).

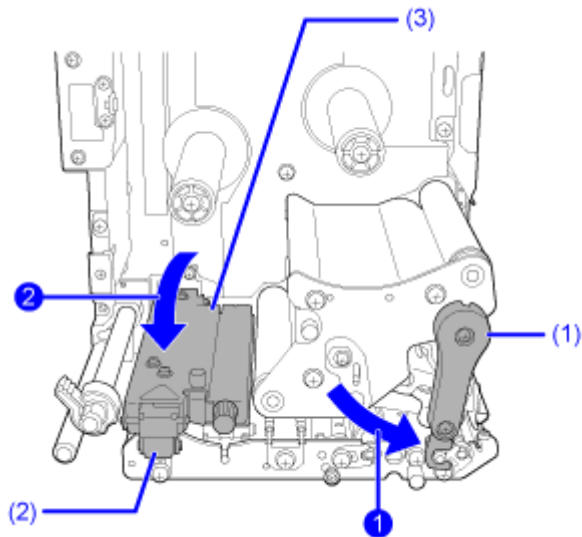

## Cleaning Using the Cleaning Sheet

The cleaning procedure using the cleaning sheet is as follows:

1. **Make sure that the product is powered off, and disconnect the power cord from the AC outlet.**
2. **Open the top cover.**



- Open the top cover fully to prevent accidental drop of the cover.
- 

3. **Turn the head lock lever (1) clockwise to unlock the print head.**



- The print head and its surroundings are hot after printing. Be careful not to get burned.
  - Touching the edge of the print head with your bare hand could cause injury.
- 

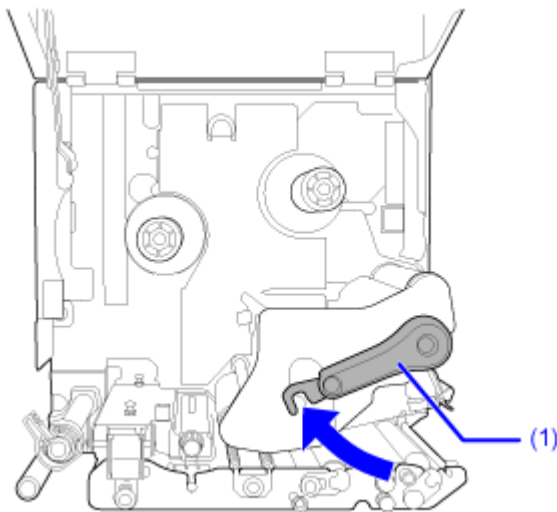

4. **Remove the media and ribbon if they are already loaded.**
5. **Place the cleaning sheet (2) between the print head and the platen roller.**



- Align the rough side of the cleaning sheet adjacent to the print head.
- 

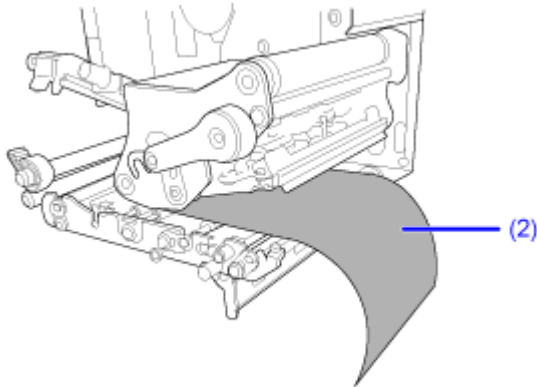

- 6. Turn the head lock lever (1) counterclockwise to lock the print head.**

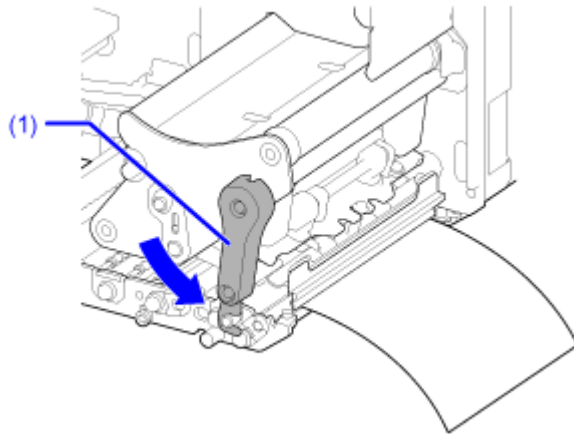

- 7. Using two hands, pull the cleaning sheet away from the product.**

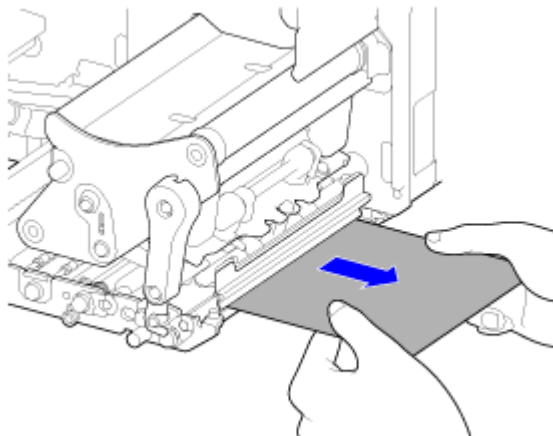

- 8. After you pull out the cleaning sheet, repeat steps 5 through 7, two or three more times.**

When no more dirt appears on the cleaning sheet after you have pulled it out, stop repeating these steps.

9. Turn the head lock lever (1) clockwise to unlock the print head.

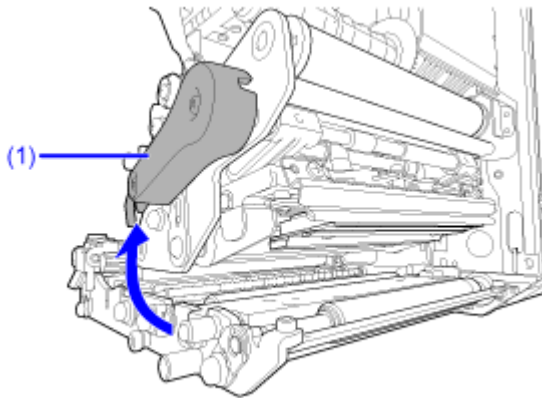

10. Use a cotton swab/cloth dabbed with cleaning liquid to clean the dirt on the print head (3).

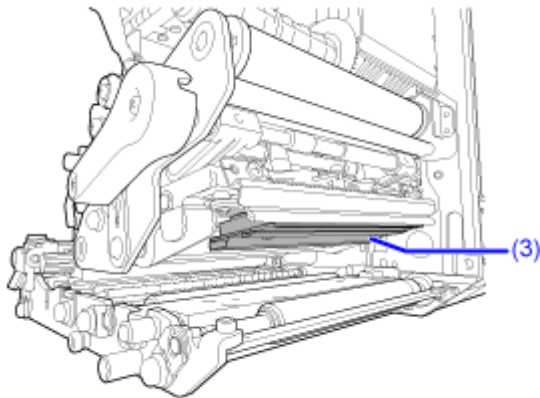



## Replacing Consumable Parts

---

### Replacing the Print Head

You can easily remove and replace a damaged or worn print head.



- Do not power on or off the product, connect or disconnect the power cord while your hands are wet. Doing so could cause an electric shock.
  - Disconnect the power cord from the AC outlet before you replace the print head.
  - Wear gloves before replacing the print head, to prevent damage to the print head.
- 

**1. Make sure that the product is powered off, and disconnect the power cord from the AC outlet.**

**2. Open the top cover.**



- Open the top cover fully to prevent accidental drop of the cover.
- 

**3. Turn the head lock lever (1) clockwise to unlock the print head.**



- The print head and its surroundings are hot after printing. Wait until the product cools down.
  - Touching the edge of the print head with your bare hand could cause injury.
- 

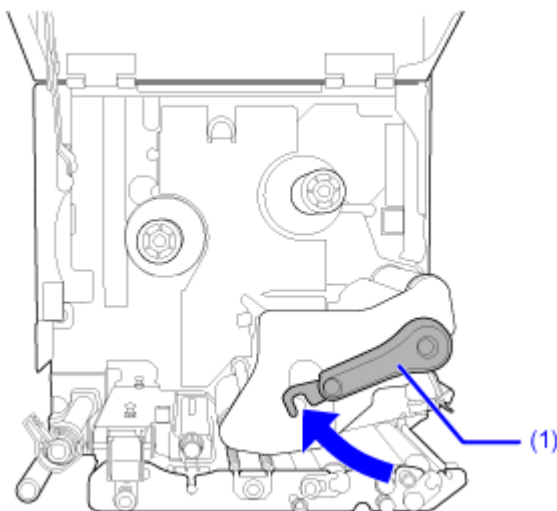

**4. Remove the media and ribbon if they are already loaded.**

5. Loosen the thumbscrew (2) attached to the cover (3) on the side of the print head assembly (1), and remove the cover (3) (2).

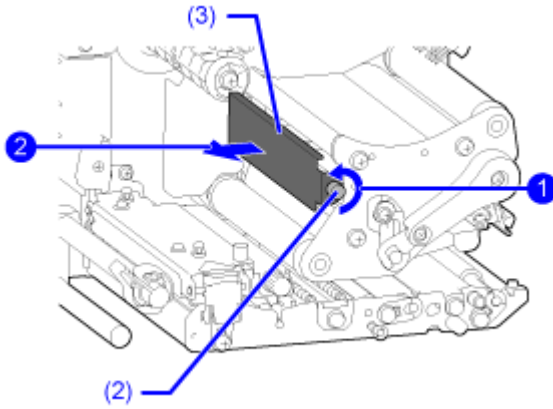

6. Pull the tab (4) to remove the print head (5).  
Support the print head with your hand when the print head is released.

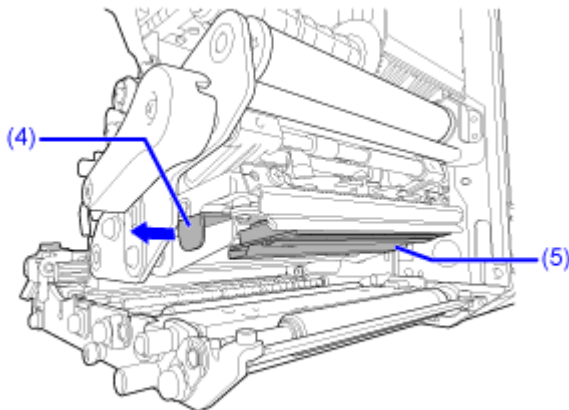

7. Pull out the print head (5) and remove all the connectors (6) from the defective print head (5).

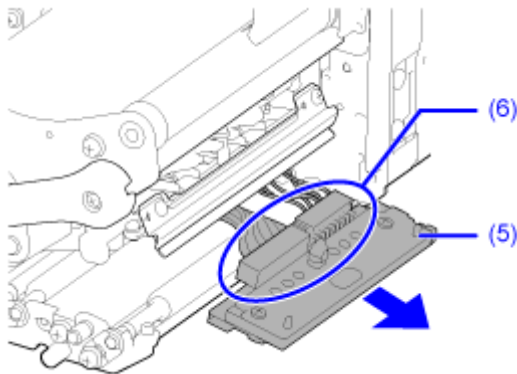



- (S84NX only) For RFID models, the UHF RFID antenna is installed on the print head. Be careful not to overly pull the antenna cable when replacing the print head. Contact your SATO reseller, dealer, or technical support for more information.

**8. Connect all the connectors (6) to the new print head.**



- Handle the print head with care. Do not contaminate or scratch the sensitive print head surface.

**9. Pull back and arrange the cables (7) from the top of the print head assembly.**

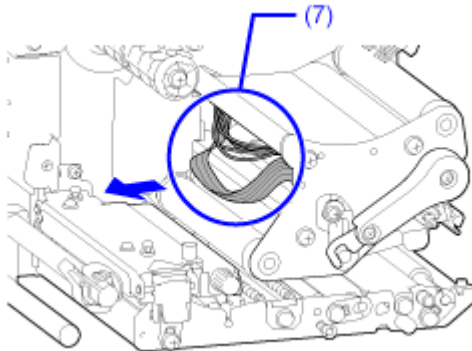

**10. Install the print head (5) to the print head assembly.**

Align the print head and press the print head upward until it is latched.

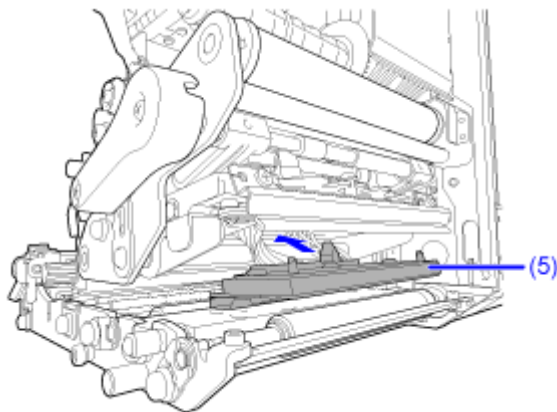

**11. Attach the cover (3) back to the top of the print head assembly ①, and tighten the thumbscrew (2) ②.**

- 
-  When attaching the cover, be careful not to pinch the wire.
- 

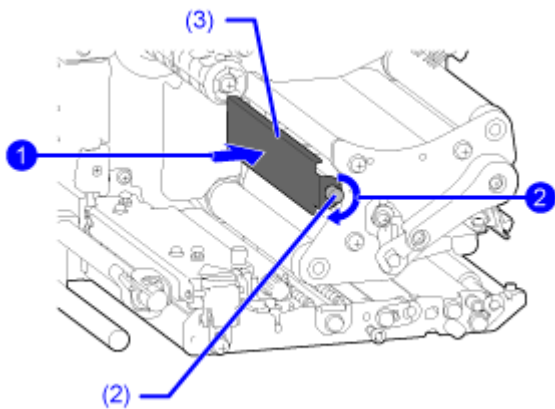

**12. Load the media and ribbon back if you remove them in step 4.**

## Replacing the Platen Roller

You can easily remove and replace a damaged or worn platen roller.



- Do not power on or off the product, connect or disconnect the power cord while your hands are wet. Doing so could cause an electric shock.
  - Disconnect the power cord from the AC outlet before you replace the platen roller.
- 



Required tool

- Phillips screwdriver
- 

### Guideline to Replace the Platen Roller

The platen roller has a striped marking on the left side. When the striped marking started to fade off, it indicates that you should replace the platen roller.



- This is only a general guideline. The condition in which the platen roller wears out varies depending on the used media. In any cases, replace the worn platen roller when it affected the printing quality of the product.
- 

- 1. Make sure that the product is powered off, and disconnect the power cord from the AC outlet.**
  - 2. Open the top cover.**
- 



- Open the top cover fully to prevent accidental drop of the cover.
- 

- 3. Turn the head lock lever (1) clockwise to unlock the print head.**



- The print head and its surroundings are hot after printing. Be careful not to get burned.
- Touching the edge of the print head with your bare hand could cause injury.

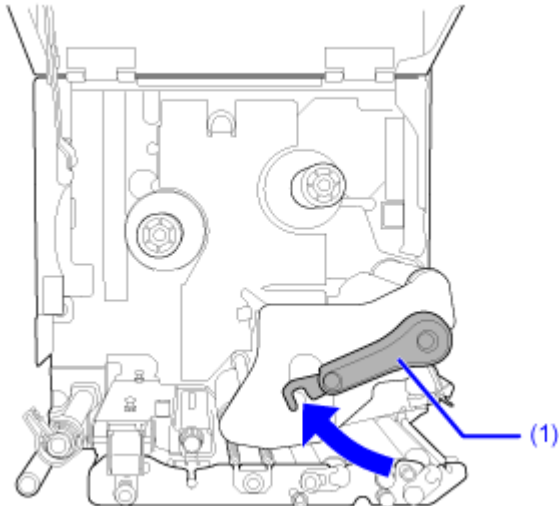

4. Loosen the screw (2) ① until the bearing clamp (3) is released ②.

Do not remove the screw.

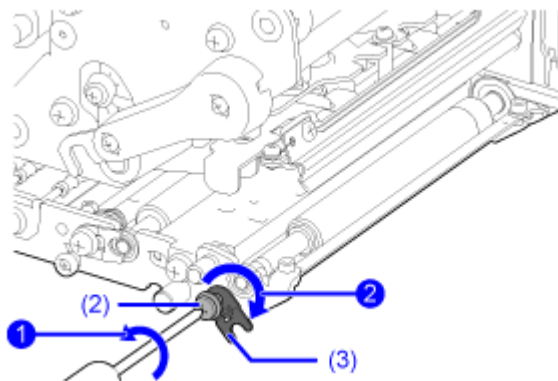

5. Remove the bearing (4) from the chassis and the shaft of the platen roller (5).

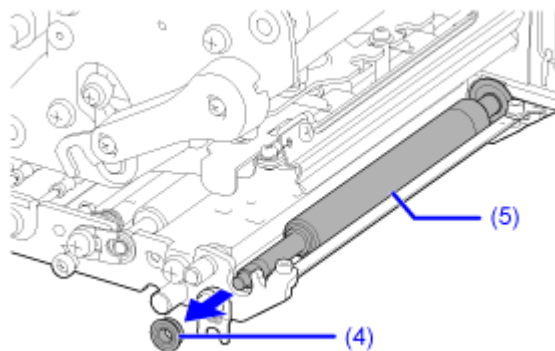

6. Pull out the platen roller (5) from the product and replace it with a new platen roller.

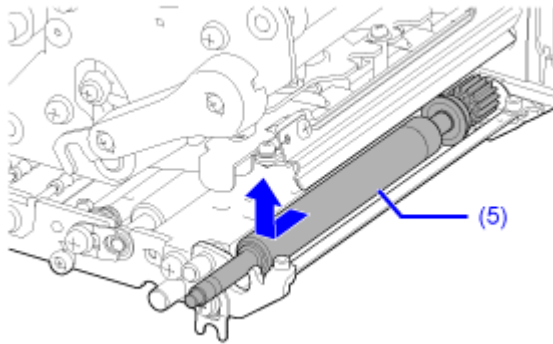

7. Insert the gear end of the platen roller (5) fully into the center frame of the product.

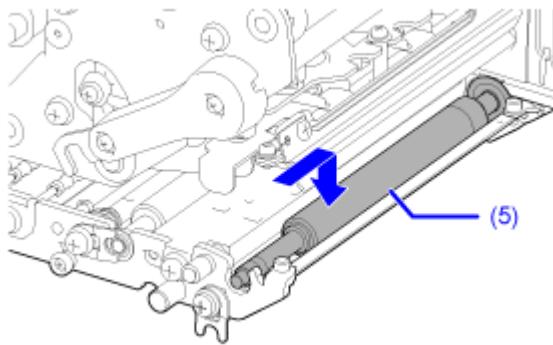

8. Place the bearing (4) back to the chassis and the shaft of the platen roller (5).

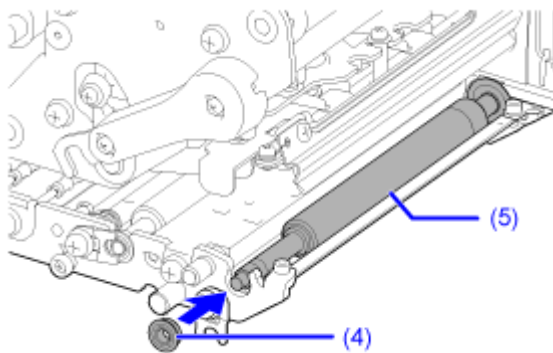

9. Rotate the bearing clamp (3) onto the bearing (1) and attach it with the screw (2).

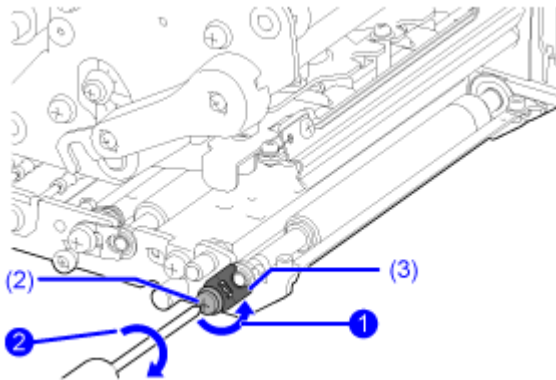



## Replacing the Pressure Roller

You can easily remove and replace a damaged or worn pressure roller.



- Do not power on or off the product, connect or disconnect the power cord while your hands are wet. Doing so could cause an electric shock.
  - Disconnect the power cord from the AC outlet before you replace the pressure roller.
- 



Required tool

- Phillips screwdriver
- 

**1. Make sure that the product is powered off, and disconnect the power cord from the AC outlet.**

**2. Open the top cover.**



- Open the top cover fully to prevent accidental drop of the cover.
- 

**3. Turn the head lock lever (1) clockwise to unlock the print head.**



- The print head and its surroundings are hot after printing. Be careful not to get burned.
  - Touching the edge of the print head with your bare hand could cause injury.
- 

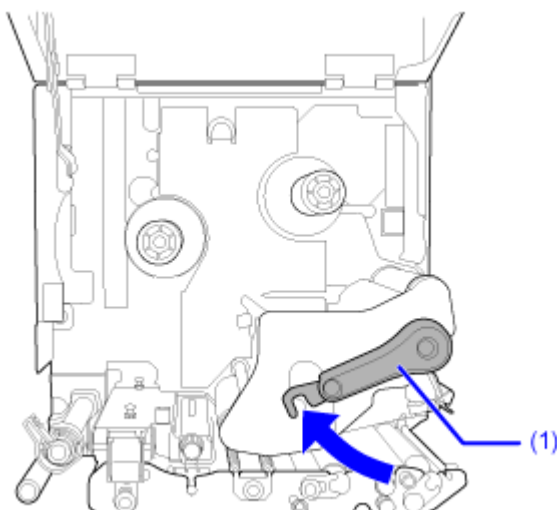

4. Push the tab (2) up to release the pressure plate (3).

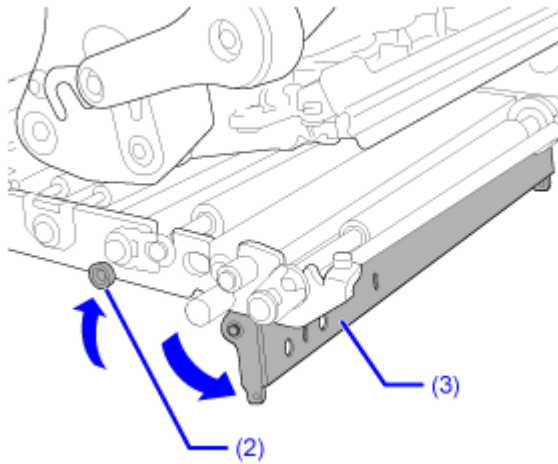

5. Loosen the screw (4) ① until the bearing clamp (5) is released ②.

Do not remove the screw.

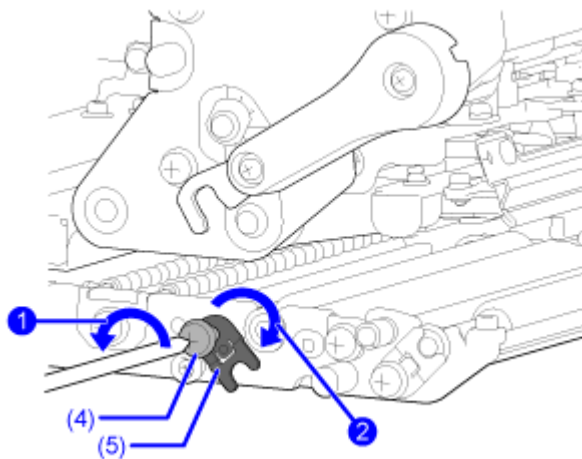

6. Remove the bearing (6) from the chassis and the shaft of the pressure roller (7).

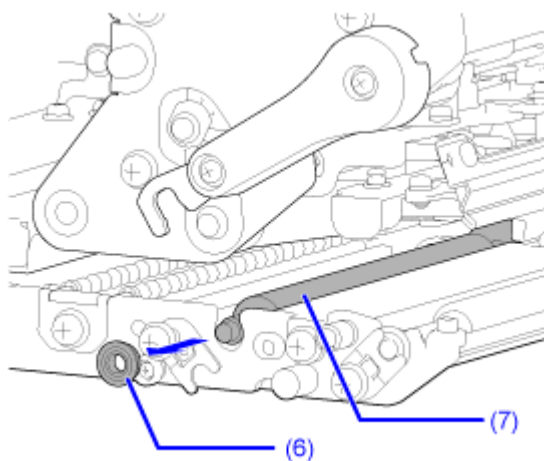

7. While pushing the tab (2) up **1**, pull out the pressure roller (7) from the product **2** and replace it with a new pressure roller.

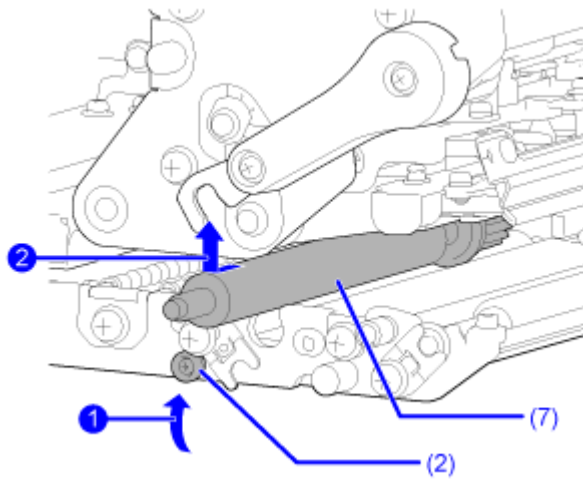

8. While pushing the tab (2) up **1**, insert the gear end of the pressure roller (7) fully into the center frame of the product **2**.

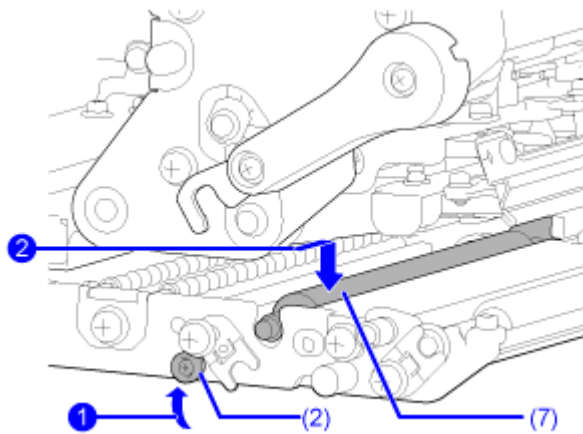

9. Place the bearing (6) back to the chassis and the shaft of the pressure roller (7).

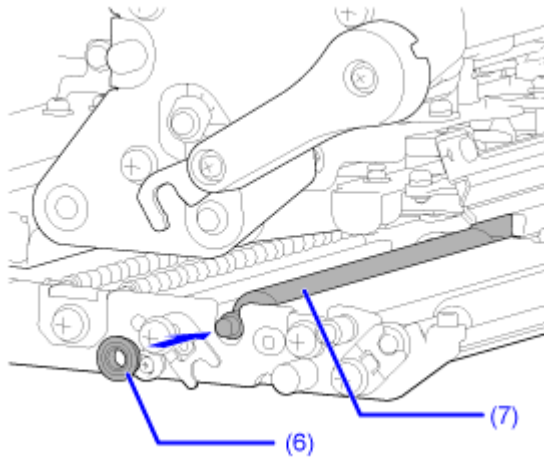

10. Rotate the bearing clamp (5) onto the bearing (1) and attach it with the screw (4) (2).

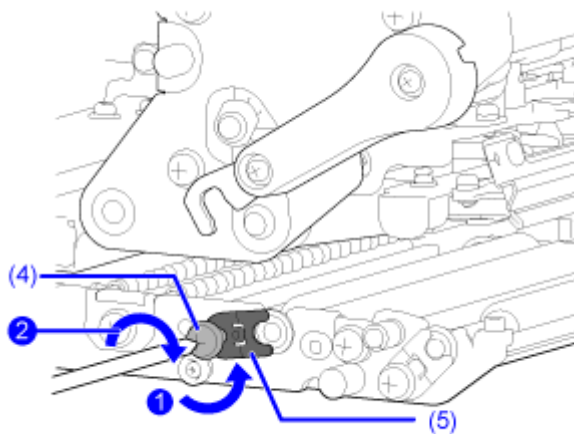

11. Push the center of the pressure plate (3) to latch it in place.

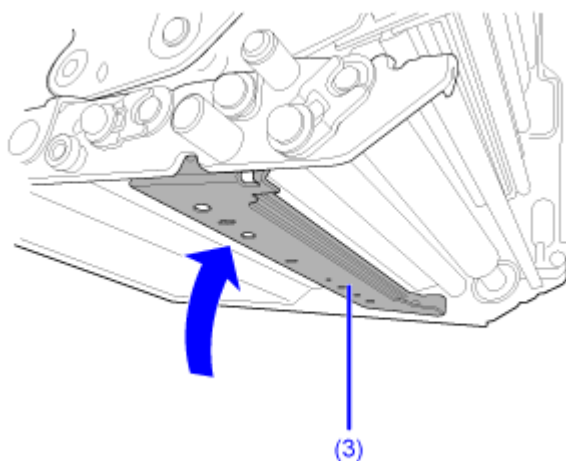

## Replacing the Pressure Plate

You can easily remove and replace a damaged or worn pressure plate.



- Do not power on or off the product, connect or disconnect the power cord while your hands are wet. Doing so could cause an electric shock.
  - Disconnect the power cord from the AC outlet before you replace the pressure plate.
- 

**1. Make sure that the product is powered off, and disconnect the power cord from the AC outlet.**

**2. Open the top cover.**



- Open the top cover fully to prevent accidental drop of the cover.
- 

**3. Turn the head lock lever (1) clockwise to unlock the print head.**



- The print head and its surroundings are hot after printing. Be careful not to get burned.
  - Touching the edge of the print head with your bare hand could cause injury.
- 

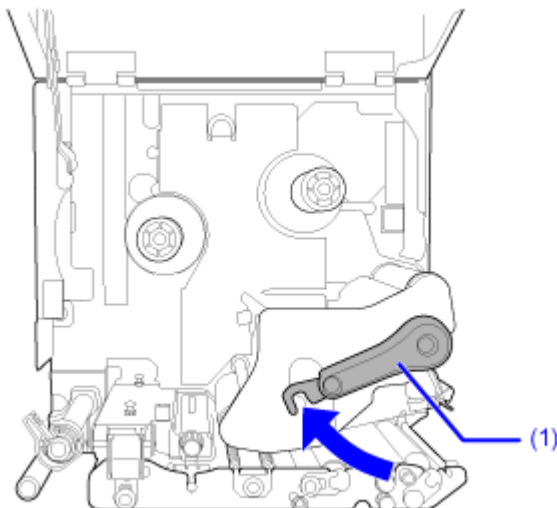

4. Push the tab (2) up to release the pressure plate (3).

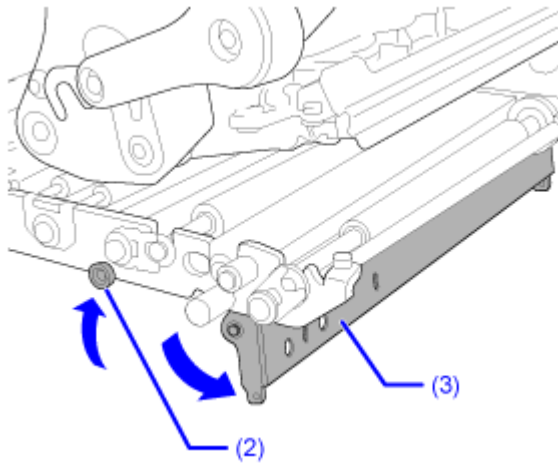

5. While supporting the pressure plate (3), loosen screw (4) until the front of the plate falls **1**, and then pull the pressure plate (3) forward to remove it **2**. Then, replace it with a new pressure plate.

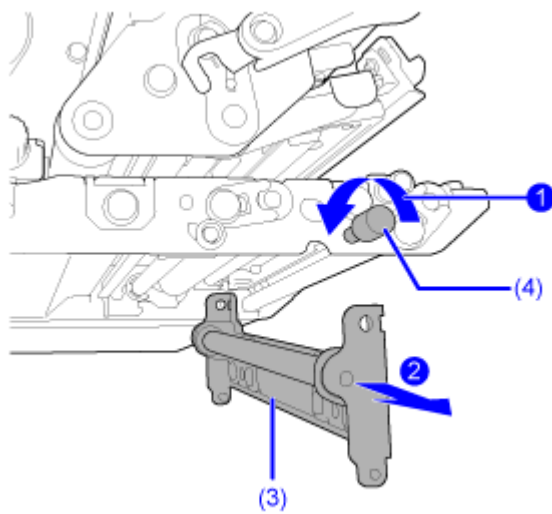

6. Insert the protrusion of the product's center frame securely into the mounting hole on the leading-edge side of the pressure plate (3).

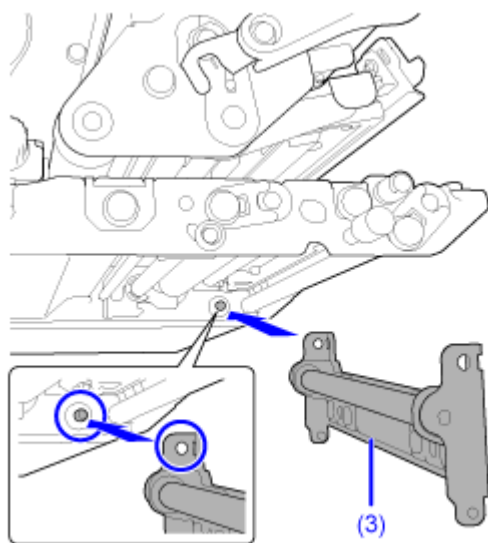

7. Align the position of the screw (4) to the mounting hole on the front side of the pressure plate (3) ①, and tighten them ②.

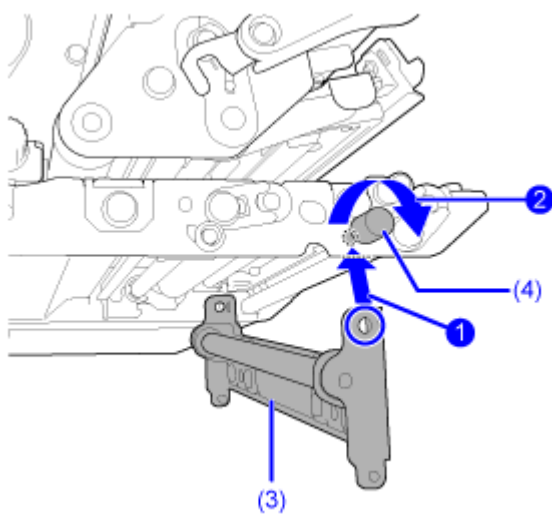

8. Push the center of the pressure plate (3) to latch it in place.

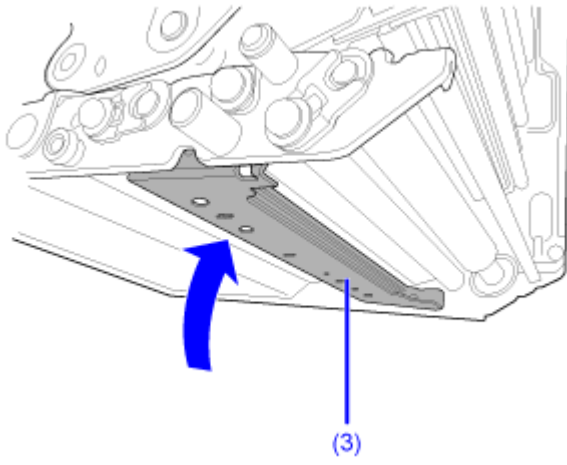



## Replacing the Feed Roller

You can easily remove and replace a damaged or worn feed roller.



- Do not power on or off the product, connect or disconnect the power cord while your hands are wet. Doing so could cause an electric shock.
  - Disconnect the power cord from the AC outlet before you replace the feed roller.
- 



Required tool

- Phillips screwdriver
- 

**1. Make sure that the product is powered off, and disconnect the power cord from the AC outlet.**

**2. Open the top cover.**



- Open the top cover fully to prevent accidental drop of the cover.
- 

**3. Pull the feed lock latch (1) to unlock the feed roller and media sensor assembly (2).**

The feed roller and media sensor assembly (2) flipped open.

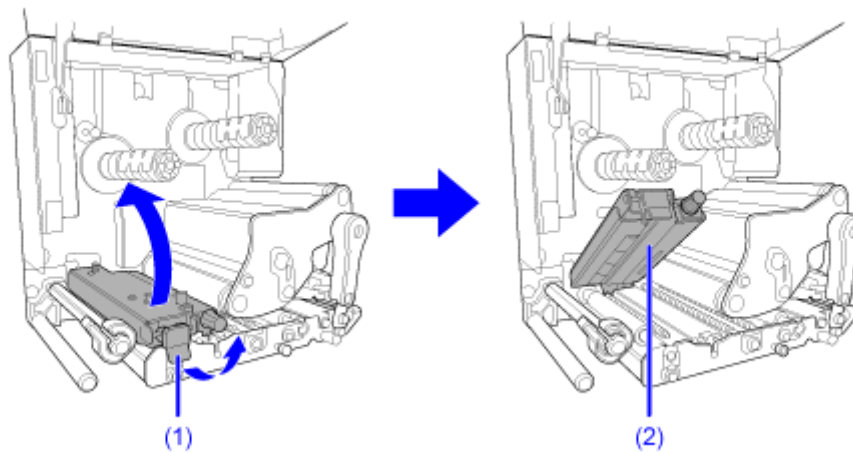

4. Loosen the screw (3) ① until the bearing clamp (4) is released ②.

Do not remove the screw.

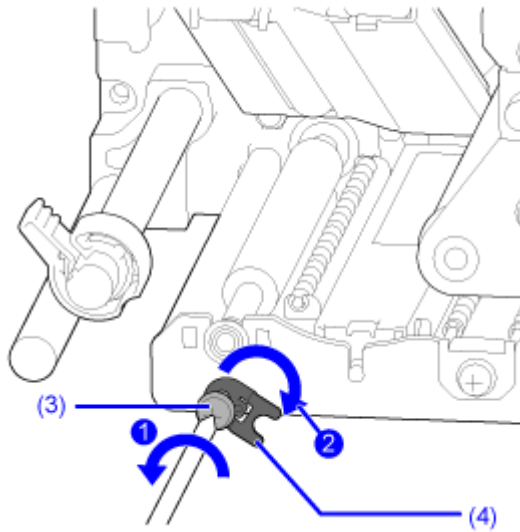

5. Remove the bearing (5) from the chassis and the shaft of the feed roller (6).

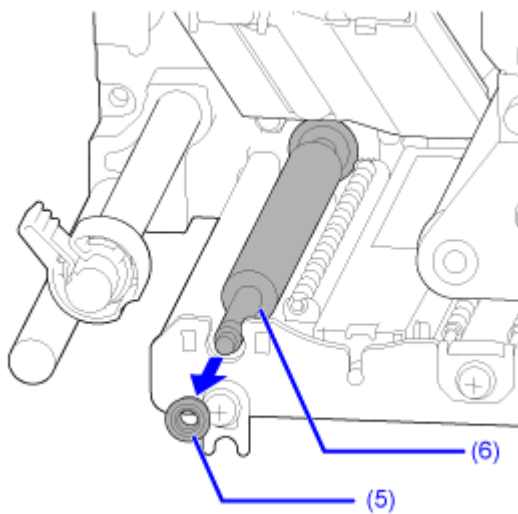

6. Pull out the feed roller (6) from the product and replace it with a new feed roller.

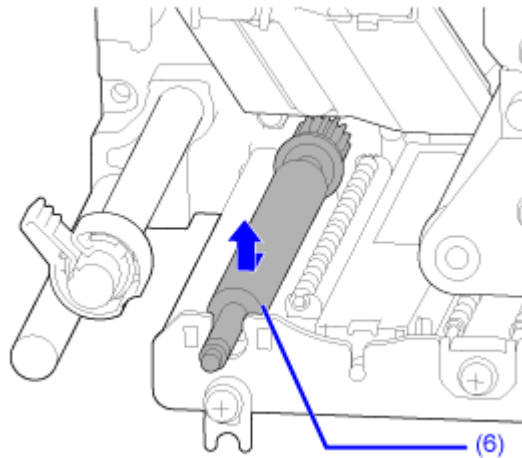

7. Insert the gear end of the new feed roller (6) fully into the center frame of the product.

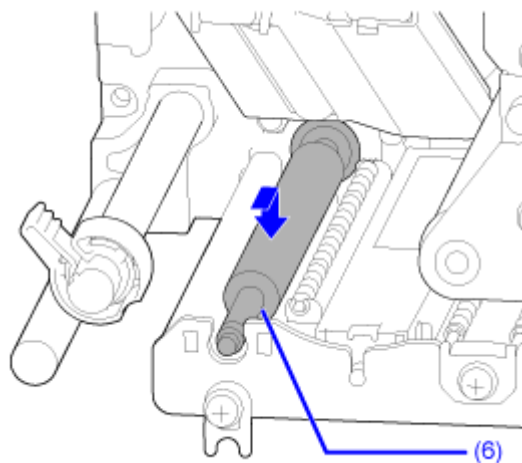

8. Place the bearing (5) back to the chassis and the shaft of the feed roller (6).

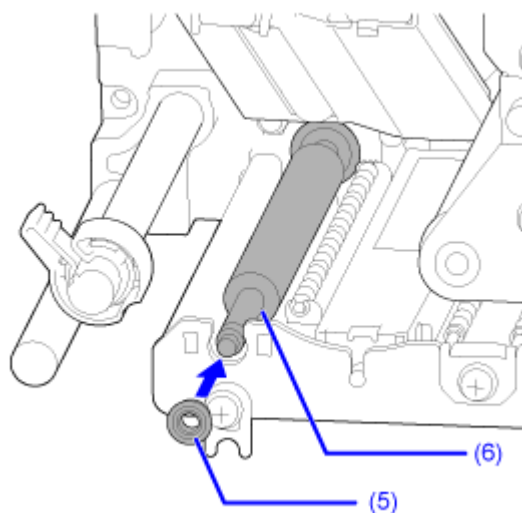

9. Rotate the bearing clamp (4) onto the bearing **1** and attach it with the screw (3) **2**.

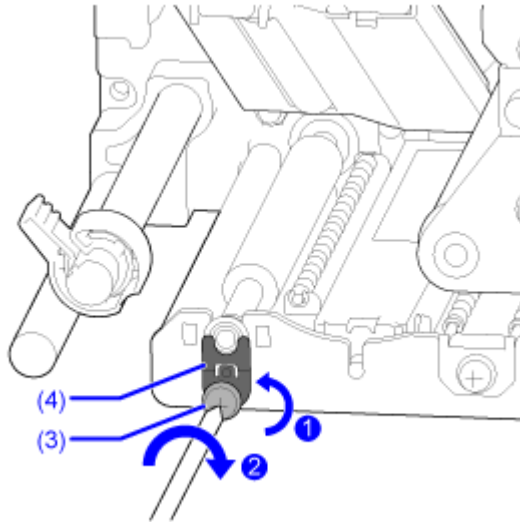

## Replacing the Fan Filter

The fan filter prevents atmospheric debris from being drawn into the product.

1. **Make sure that the product is powered off, and disconnect the power cord from the AC outlet.**
2. **Peel off the old fan filter (1) from the rear of the product.**

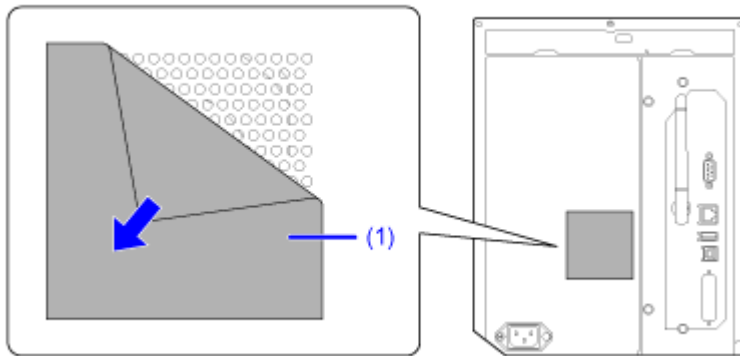

3. **Clean the product to remove any adhesive residue on the surface.**
4. **Remove the backing paper from the new fan filter (1) and paste the fan filter (1) over the fan exhaust holes.**

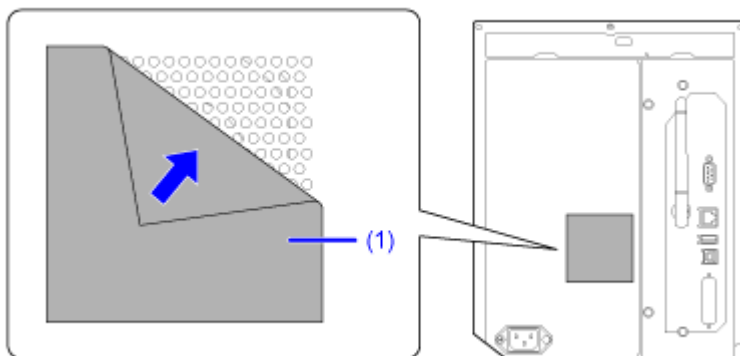

## Operating the Notification Screen of the SOS (SATO Online Services) On-Demand Mode (SOS users only)

In the SOS (SATO Online Services) function, the product information is sent to the SOS cloud and monitored and managed.

The status icon **SOS!** and the notification screen appear at the time specified when [SOS Mode] is set to [On-Demand] in the [Interface] > [Network] > [Services] > [Online Services] menu and [Periodic Notification] is enabled on the product. A QR code with the product information is displayed on the notification screen. You can send the product information to the SOS cloud by scanning the QR code with a tablet or a smartphone.

The following shows how to operate the notification screen.

The soft key function changes according to the setting of [Update Screen].

### When [Update Screen] Is Set to [Normal]



By pressing the  button, the display returns to the Offline screen without resetting the QR code for periodic notification.

The status icon remains **SOS!**.

By pressing the  button, the QR code for periodic notification is reset and the display returns to the Offline screen.

The status icon changes to **SOS**.

### When [Update Screen] Is Set to [Print]

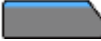

By pressing the  button, the QR code for periodic notification is reset and the display returns to the Offline screen.

The status icon changes to **SOS**.

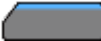
By pressing the  button, the QR code for periodic notification is printed.



- QR codes can also be displayed from [Daily Checkup].
-

## SOS (SATO Online Services) Application (SOS users only)

---

When the SOS (SATO Online Services) mode is enabled on the product, a QR code is displayed on the screen at the time of the error outbreak or the timing that is set to perform periodic notification. By scanning the QR code with a tablet or a smartphone, you can check how to clear the error according to the current product information in the QR code. You can also contact your SATO technical support directly from this specialized application by phone or e-mail.

Also, the product information can be acquired via NFC and sent to the SOS cloud.

The SOS application allows you to check the operation information of the product, save and apply clones, and request repairs. You can also use asset management functions in the SOS cloud.

For instructions on installing and using the SOS application, refer to the SOS application user's manual.



[https://www.sato-sos.com/en/support/#sos\\_use\\_manual](https://www.sato-sos.com/en/support/#sos_use_manual)



---

# When You Are in Trouble

---

## When an Error Message Appears

---

### Error Message 1001 (Machine Error)

When there is an error with the product, the error message appears on the screen.

Check the cause and countermeasure, and then take appropriate action.



To clear the error:

Power off the product.

Cause and Countermeasure	Reference
<p><b>Cause</b></p> <p>A defect has occurred in the product.</p> <p><b>Countermeasure</b></p> <p>Power the product off and then on again.</p>	<p> <a href="#">Powering On/Off the Product</a></p>

Contact your SATO technical support if the error cannot be resolved.

 [Contact Information for When You Are in Trouble](#)

## Error Message 1002 (Program Error)

When there is an error with the product, the error message appears on the screen.

Check the cause and countermeasure, and then take appropriate action.



To clear the error:

Power off the product.

Cause and Countermeasure	Reference
<p><b>Cause</b></p> <p>A program error occurred in the memory.</p> <p><b>Countermeasure</b></p> <p>Power the product off and then on again.</p>	<p> <a href="#">Powering On/Off the Product</a></p>

Contact your SATO technical support if the error cannot be resolved.

 [Contact Information for When You Are in Trouble](#)



## Error Message 1003 (Parity Error)

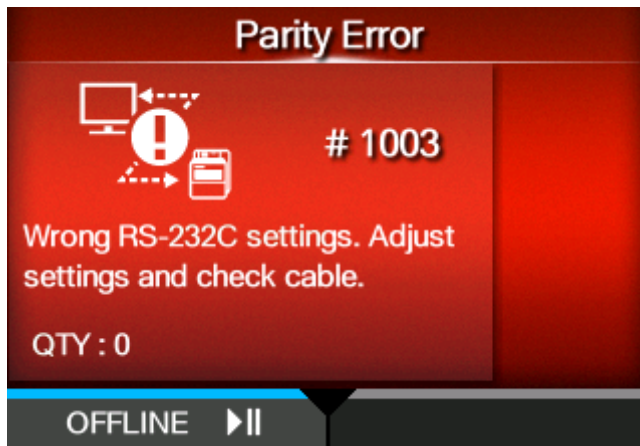

When there is an error with the product, the error message appears on the screen.

Check the cause and countermeasure, and then take appropriate action.

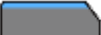

To clear the error:

Press the  button (OFFLINE) or  button, or adjust the settings.

Cause and Countermeasure	Reference
<p><b>Cause (1)</b> RS-232C settings are incorrect.</p> <p><b>Countermeasure (1)</b> Set the interface settings of the product again.</p>	<p> <a href="#">RS-232C</a></p>
<p><b>Cause (2)</b> The RS-232C cable is not connected correctly.</p> <p><b>Countermeasure (2)</b> Power off the product, connect the RS-232C cable correctly, and then power on the product again.</p>	<p> <a href="#">Powering On/Off the Product</a></p> <p> <a href="#">RS-232C Interface Connection (Standard)</a></p>

Contact your SATO technical support if the error cannot be resolved.

 [Contact Information for When You Are in Trouble](#)



## Error Message 1004 (Overrun Error)

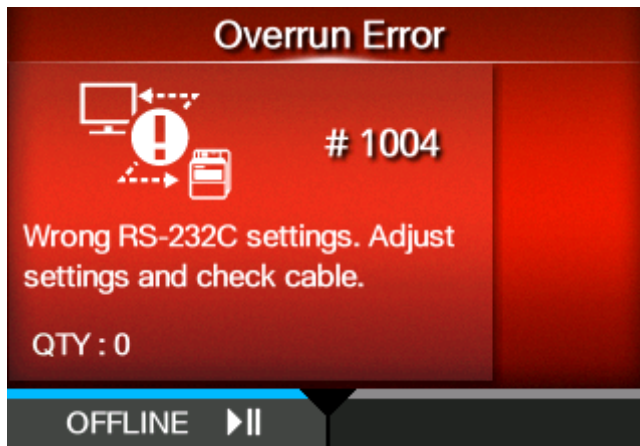

When there is an error with the product, the error message appears on the screen.

Check the cause and countermeasure, and then take appropriate action.



To clear the error:

Press the  button (OFFLINE) or  button, or adjust the settings.

Cause and Countermeasure	Reference
<p><b>Cause (1)</b> RS-232C settings are incorrect.</p> <p><b>Countermeasure (1)</b> Set the interface settings of the product again.</p>	<p> <a href="#">RS-232C</a></p>
<p><b>Cause (2)</b> The RS-232C cable is not connected correctly.</p> <p><b>Countermeasure (2)</b> Power off the product, connect the RS-232C cable correctly, and then power on the product again.</p>	<p> <a href="#">Powering On/Off the Product</a></p> <p> <a href="#">RS-232C Interface Connection (Standard)</a></p>

Contact your SATO technical support if the error cannot be resolved.

 [Contact Information for When You Are in Trouble](#)



## Error Message 1005 (Framing Error)

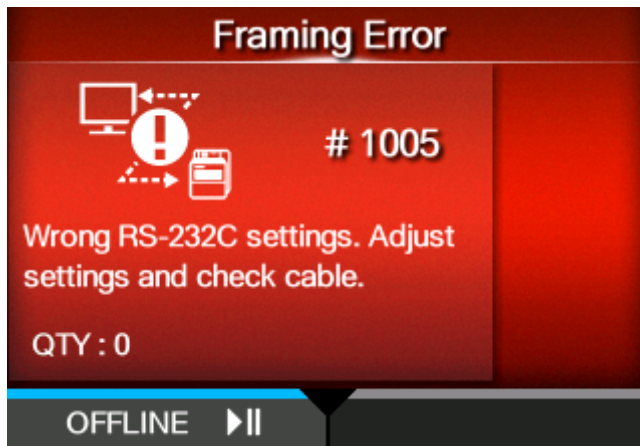

When there is an error with the product, the error message appears on the screen.

Check the cause and countermeasure, and then take appropriate action.



To clear the error:

Press the  button (OFFLINE) or  button, or adjust the settings.

Cause and Countermeasure	Reference
<p><b>Cause (1)</b> RS-232C settings are incorrect.</p> <p><b>Countermeasure (1)</b> Set the interface settings of the product again.</p>	<p> <a href="#">RS-232C</a></p>
<p><b>Cause (2)</b> The RS-232C cable is not connected correctly.</p> <p><b>Countermeasure (2)</b> Power off the product, connect the RS-232C cable correctly, and then power on the product again.</p>	<p> <a href="#">Powering On/Off the Product</a></p> <p> <a href="#">RS-232C Interface Connection (Standard)</a></p>

Contact your SATO technical support if the error cannot be resolved.

 [Contact Information for When You Are in Trouble](#)



## Error Message 1006 (Buffer Overflow)

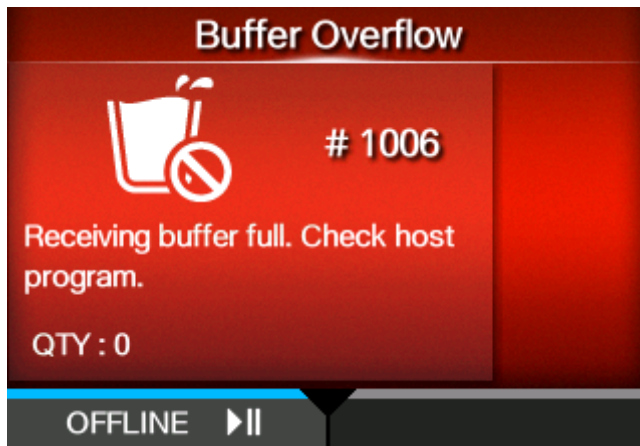

When there is an error with the product, the error message appears on the screen.

Check the cause and countermeasure, and then take appropriate action.



To clear the error:

Press the  button (OFFLINE) or  button, or adjust the settings.

Cause and Countermeasure	Reference
<p><b>Cause (1)</b></p> <p>The size of the received data from the host exceeds the size of the receive buffer.</p> <p><b>Countermeasure (1)</b></p> <p>Change the settings on the host so that data that exceeds the size of the receive buffer cannot be sent.</p>	<p>-</p>
<p><b>Cause (2)</b></p> <p>The interface settings between the product and the host are incorrect.</p> <p><b>Countermeasure (2)</b></p> <p>Set the interface settings of the product and host again.</p>	<p> <a href="#">Interface Menu</a></p> <p> <a href="#">Go to your local SATO website</a></p>

Contact your SATO technical support if the error cannot be resolved.

 [Contact Information for When You Are in Trouble](#)

## Error Message 1007 (Head Open)

When there is an error with the product, the error message appears on the screen.

Check the cause and countermeasure, and then take appropriate action.



To clear the error:

Lock the print head.

### Cause and Countermeasure

#### Cause

- The print head is unlocked.
- The sensor for detecting the open/close status of the print head is defective.

#### Countermeasure

Unlock the print head once, and then lock it again.

1. Turn the head lock lever (1) clockwise to unlock the print head.

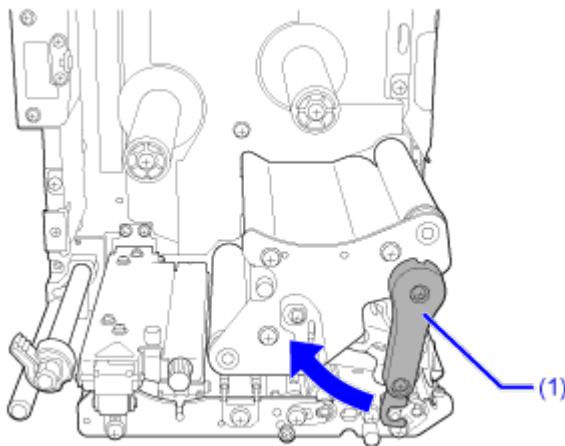

## Cause and Countermeasure

2. Turn the head lock lever (1) counterclockwise to lock the print head.

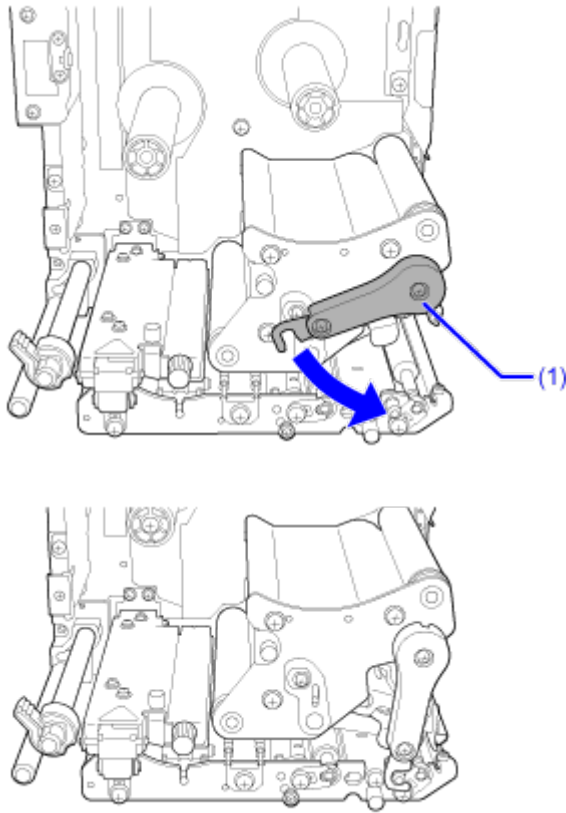

Contact your SATO technical support if the error cannot be resolved.

 [Contact Information for When You Are in Trouble](#)





## Error Message 1008 (Out of Paper)



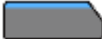

When there is an error with the product, the error message appears on the screen.

Check the cause and countermeasure, and then take appropriate action.



To clear the error:

Load the media and open/close the print head, or press the  button (OFFLINE) or the  button.

Cause and Countermeasure	Reference
<p><b>Cause (1)</b> The media is not loaded.</p> <p><b>Countermeasure (1)</b> Load the media.</p>	<p> <a href="#">Loading Media</a></p>
<p><b>Cause (2)</b> The media is not loaded correctly.</p> <p><b>Countermeasure (2)</b> Load the media correctly.</p>	<p> <a href="#">Loading Media</a></p>
<p><b>Cause (3)</b> The media sensor level is not set correctly.</p> <p><b>Countermeasure (3)</b> Adjust the media sensor level.</p>	<p> <a href="#">Calibrate</a></p>
<p><b>Cause (4)</b> The media has jammed.</p>	<p> <a href="#">Loading Media</a></p>

Cause and Countermeasure	Reference
<p><b>Countermeasure (4)</b></p> <p>Remove the jammed media.</p> <p>Refer to the video for loading the media, for the media path, and for the operation of each part inside the product.</p>	
<p><b>Cause (5)</b></p> <p>The media sensor is not operating correctly.</p> <ul style="list-style-type: none"> <li>◦ The media sensor is dirty, or there is a label attached to it.</li> <li>◦ The media sensor has poor sensitivity.</li> </ul> <p><b>Countermeasure (5)</b></p> <p>Clean the media sensor.</p>	<p> <a href="#">Cleaning Using the Cleaning Kit</a></p>

Contact your SATO technical support if the error cannot be resolved.

 [Contact Information for When You Are in Trouble](#)



## Error Message 1009 (Ribbon End)



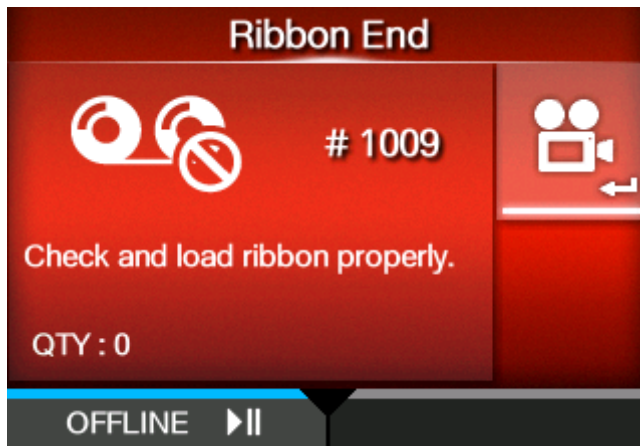

When there is an error with the product, the error message appears on the screen.

Check the cause and countermeasure, and then take appropriate action.



To clear the error:

Load the ribbon correctly and close the print head, or press the  button (OFFLINE) or  button.

Cause and Countermeasure	Reference
<p><b>Cause (1)</b> The ribbon is not loaded.</p> <p><b>Countermeasure (1)</b> Load the ribbon.</p>	<p> <a href="#">Loading Ribbon (Thermal Transfer Only)</a></p>
<p><b>Cause (2)</b> The ribbon is not loaded correctly.</p> <p><b>Countermeasure (2)</b> Load the ribbon and the media correctly.</p>	<p> <a href="#">Loading Ribbon (Thermal Transfer Only)</a></p> <p> <a href="#">Loading Media</a></p>
<p><b>Cause (3)</b> There is no ribbon.</p> <p><b>Countermeasure (3)</b> Load a new ribbon.</p>	<p> <a href="#">Loading Ribbon (Thermal Transfer Only)</a></p>
<p><b>Cause (4)</b> The ribbon sensor is not operating correctly.</p> <ul style="list-style-type: none"> <li>◦ The ribbon sensor is dirty.</li> <li>◦ The ribbon sensor has poor sensitivity.</li> </ul>	<p> <a href="#">Powering On/Off the Product</a></p>

Cause and Countermeasure	Reference
<b>Countermeasure (4)</b> Power on the product again.	

Contact your SATO technical support if the error cannot be resolved.



[Contact Information for When You Are in Trouble](#)

## Error Message 1010 (Media Error)

When there is an error with the product, the error message appears on the screen.

Check the cause and countermeasure, and then take appropriate action.

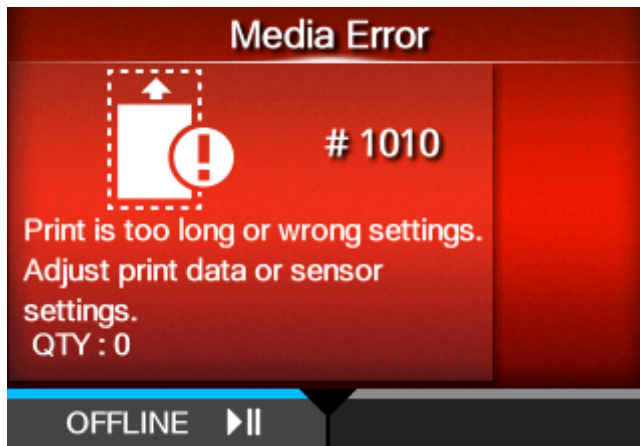

To clear the error:

Open/close the print head, or press the  button (OFFLINE) or the  button.

Cause and Countermeasure	Reference
<p><b>Cause (1)</b></p> <p>The media size of the print data and the actual media size are different.</p> <p><b>Countermeasure (1)</b></p> <p>Check the media size of the print data and the actual media size again.</p> <p>If the error is not solved, power on the product again.</p>	-
<p><b>Cause (2)</b></p> <p>The media size of the print data is longer than the actual media size.</p> <p><b>Countermeasure (2)</b></p> <p>Check the print data.</p> <p>If the error is not solved, power on the product again.</p>	-
<p><b>Cause (3)</b></p> <p>The media is fed a longer distance due to the incorrect sensor level.</p>	 <a href="#">Calibrate</a>

Cause and Countermeasure	Reference
<p><b>Countermeasure (3)</b></p> <p>Adjust the media sensor level.</p> <p>If the error is not solved, power on the product again.</p>	



- The media error appears when [Check Media Size] in [Advanced] under the [Printing] menu is set to [Enabled].



[Check Media Size](#)

---

Contact your SATO technical support if the error cannot be resolved.



[Contact Information for When You Are in Trouble](#)

## Error Message 1012 (Head Error)

When there is an error with the product, the error message appears on the screen.

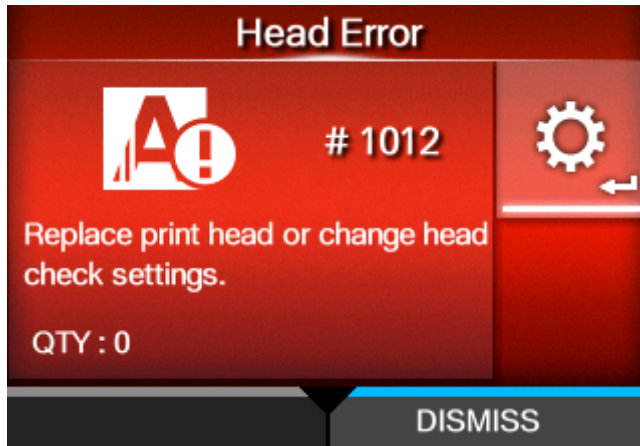

Check the cause and countermeasure, and then take appropriate action.

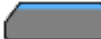

To clear the error:

Power off the product, or change print head check conditions.

To forcibly clear the head error and resume printing, press and hold the  button (DISMISS) until the progress bar on the blue line of the button reaches to the right end.

Cause and Countermeasure	Reference
<p><b>Cause (1)</b> The print elements are worn out.</p> <p><b>Countermeasure (1)</b> Power off the product, or change the print head check conditions to only check for missing elements in barcodes and try to adjust missing elements to white bars.</p>	<p> <a href="#">Powering On/Off the Product</a></p> <p> <a href="#">Head Check</a></p>
<p><b>Cause (2)</b> The print head is worn or damaged.</p> <p><b>Countermeasure (2)</b> Replace the print head.</p>	<p> <a href="#">Replacing the Print Head</a></p>

Contact your SATO technical support if the error cannot be resolved.

 [Contact Information for When You Are in Trouble](#)



- Regarding labels output after a head error, use your own barcode scanner to read and check the printed barcodes.



## Error Message 1013 (USB R/W Error)

When there is an error with the product, the error message appears on the screen.

Check the cause and countermeasure, and then take appropriate action.

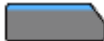

To clear the error:

Connect the USB memory and then disconnect it, or press the  button (OFFLINE) or the  button.

### Cause and Countermeasure

#### Cause (1)

The USB memory is disconnected while writing.

#### Countermeasure (1)

Connect the USB memory.

#### Cause (2)

The copy area in the USB memory is not sufficient.

#### Countermeasure (2)

Make sure that the USB memory has sufficient copy area.

#### Cause (3)

Writing to the USB memory fails.

#### Countermeasure (3)

Replace the USB memory.

#### Cause (4)

The USB memory is not formatted.



## Cause and Countermeasure

### Countermeasure (4)

Format the USB memory to FAT32 format.

Contact your SATO technical support if the error cannot be resolved.



[Contact Information for When You Are in Trouble](#)



## Error Message 1014 (USB Memory Full)

When there is an error with the product, the error message appears on the screen.

Check the cause and countermeasure, and then take appropriate action.



To clear the error:

Connect the USB memory with sufficient space, or press the  button (OFFLINE) or  button.

### Cause and Countermeasure

#### Cause

The space in the USB memory is not sufficient.

#### Countermeasure

Delete unwanted data from the USB memory or insert a USB memory with sufficient space.

Contact your SATO technical support if the error cannot be resolved.

 [Contact Information for When You Are in Trouble](#)

## Error Message 1017 (SBPL Command Error)



When there is an error with the product, the error message appears on the screen.

Check the cause and countermeasure, and then take appropriate action.



To clear the error:

Press the  button (CANCEL).

Cause and Countermeasure	Reference
<p><b>Cause</b></p> <p>Incorrect command or parameter in the print data.</p> <p>For details about the error, check the "Caaa: &lt;bb&gt;: cc" part below the error number.</p> <ul style="list-style-type: none"><li>◦ Caaa: position of error occurrence</li><li>◦ &lt;bb&gt;: error command name</li><li>◦ cc: error content</li></ul> <p><b>Countermeasure</b></p> <p>Check the print data.</p> <p>If the error is not solved, power on the product again.</p> <hr/> <p> • The command error appears when [Show Error] in [SBPL] under the [Applications] menu is set to [Enabled].</p> <hr/>	<p> <a href="#">How to See the Command Error Information</a></p> <p> <a href="#">Show Error</a></p>

Contact your SATO technical support if the error cannot be resolved.

 [Contact Information for When You Are in Trouble](#)

## How to See the Command Error Information

- **Location of error occurrence**

"Caaa" in the command error message shows the location of command error.  
 The number of ESC commands from start code <A> command is shown in "aaa".  
 Note that the start code <A> command is not included in the number of ESC commands, which can be shown up to 999.  
 When a command error is detected by the Horizontal Print Position <H> command.

```
-----: [ESC]A
C001: [ESC]V100
C002: [ESC]H99999
C003: [ESC]L0202
C004: [ESC]M,ABCDEF
C005: [ESC]Q1
C006: [ESC]Z
```

In this case, C002 is the location of the error.

- **Error command name**

The command name is shown in "<bb>". Error is detected in the command name.

- A one-byte command name is left aligned

- **Error description**

The cause of command error appears in "cc" in the error message ("Caaa:<bb>:cc").

Description ("cc")	Cause
Invalid command	Analyzed improper command.
Invalid parameter	Received improper parameter.
Command table read error	Failed to read the command table.
Invalid graphic data/ custom designed data	Analyzed improper graphic and custom designed data.
Invalid registration area	<ul style="list-style-type: none"> <li>• Specified memory area (card slot) is inappropriate.</li> <li>• Tried to write to a write-protected media.</li> </ul>
This number is already registered.	Number specified by registration command has already been taken.
Over registration area limit	Exceeded the registration area. (Memory full)
Data is not registered	Data, such as form overlay, is not registered.

Description ("cc")	Cause
Printing position is out of printable area	The specified print start position is outside the printable area.
Barcode image is out of printable area	The printing image is outside the printable area. (Barcode only)



## Error Message 1019 (RFID System Error) (S84NX Only)

When there is an error with the product, the error message appears on the screen.

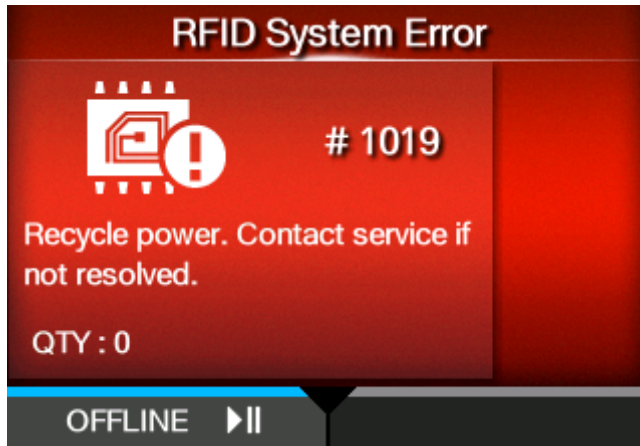
Check the cause and countermeasure, and then take appropriate action.

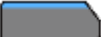

To clear the error:

Press the  button (OFFLINE) or  button.

Because the RFID module is not operating correctly, writing information to inlays or reading information from inlays cannot be executed, but printing on the surface of tags can be done.

Cause and Countermeasure	Reference
<p><b>Cause</b></p> <p>RFID module is not operating correctly.</p> <p><b>Countermeasure</b></p> <p>Repair or replacement of the RFID module is required. Contact your SATO technical support.</p>	<p> <a href="#">Contact Information for When You Are in Trouble</a></p>

## Error Message 1020 (Calendar Error)

When there is an error with the product, the error message appears on the screen.

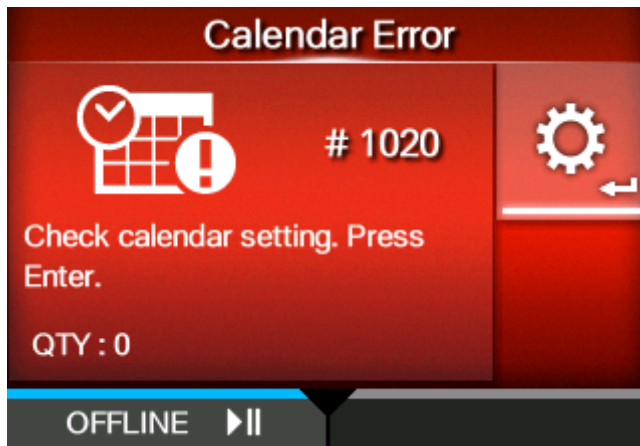

Check the cause and countermeasure, and then take appropriate action.



To clear the error:

Press the  button to check that the date and time are set correctly.

After that, press the  button (OFFLINE) or  button on the error screen.

Cause and Countermeasure	Reference
<p><b>Cause (1)</b></p> <p>The date and time of the calendar are incorrect.</p> <p><b>Countermeasure (1)</b></p> <p>Set the calendar again.</p>	<p> <a href="#">Regional</a></p>
<p><b>Cause (2)</b></p> <p>The battery for the calendar is running low.</p> <p><b>Countermeasure (2)</b></p> <p>The battery for the calendar needs to be changed. Contact your SATO technical support.</p>	<p> <a href="#">Contact Information for When You Are in Trouble</a></p>

## Error Message 1021 (BCC Check Error)

When there is an error with the product, the error message appears on the screen.

Check the cause and countermeasure, and then take appropriate action.

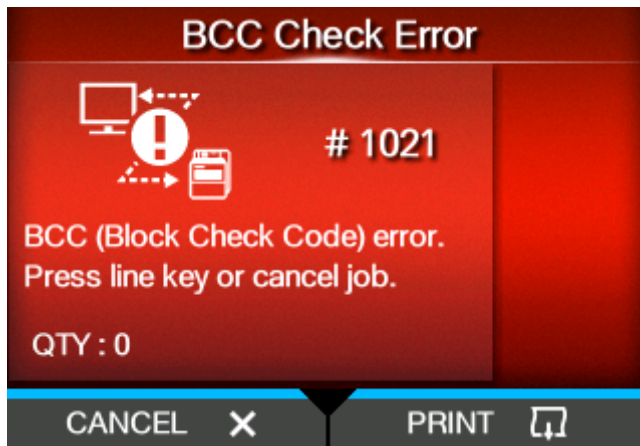

To clear the error:

Press the  button (CANCEL).

### Cause and Countermeasure

#### Cause

The BCC code of the transmitted data (one item) is incorrect.

#### Countermeasure

Check the transmitted data and interface settings.

- [PRINT]: Continue printing from the print data where the BCC error occurred.
- [CANCEL]: Cancel the print data where the BCC error occurred and continue printing from the next item.
- Send the SUB command: Clear the BCC error and continue printing from where it stopped.
- Send the CAN command: Cancel the print data where the BCC error occurred and continue printing from the next item.

Contact your SATO technical support if the error cannot be resolved.

 [Contact Information for When You Are in Trouble](#)



## Error Message 1022 (Print Head Overheated)

When there is an error with the product, the error message appears on the screen.  
Check the cause and countermeasure, and then take appropriate action.



To clear the error:

Stop the operation of the product to let the temperature decrease.

### Cause and Countermeasure

#### Cause

The temperature of the product has exceeded its tolerance value.

#### Countermeasure

Stop the operation of the product to let the temperature decrease.

Contact your SATO technical support if the error cannot be resolved.

 [Contact Information for When You Are in Trouble](#)

## Error Message 1023 (NTP Error)

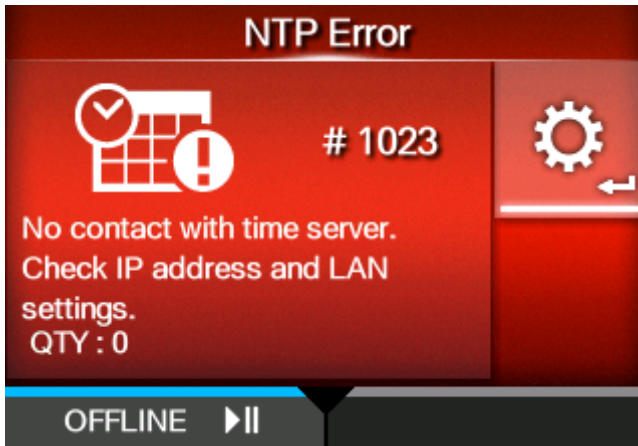

When there is an error with the product, the error message appears on the screen.

Check the cause and countermeasure, and then take appropriate action.



To clear the error:

Press the  button (OFFLINE) or  button, or change the calendar setting.

Cause and Countermeasure	Reference
<p><b>Cause</b></p> <p>Could not connect to the time server and set the date and time.</p> <p><b>Countermeasure</b></p> <ul style="list-style-type: none"> <li>◦ Confirm that the address of the time server is correct.</li> <li>◦ Confirm that there is a connection to the time server.</li> <li>◦ The calendar can be set manually and operation can be resumed without NTP functionality.</li> </ul>	<p> <a href="#">Time Server IP</a></p> <p> <a href="#">Regional</a></p>

Contact your SATO technical support if the error cannot be resolved.

 [Contact Information for When You Are in Trouble](#)

## Error Message 1024 (Head Density Changed)



When there is an error with the product, the error message appears on the screen.

Check the cause and countermeasure, and then take appropriate action.



To clear the error:

Check the message that appeared on the screen.

Cause and Countermeasure	Reference
<p><b>Cause (1)</b></p> <p>The print head is not installed.</p> <p><b>Countermeasure (1)</b></p> <p>Install the print head.</p>	<p> <a href="#">Replacing the Print Head</a></p>
<p><b>Cause (2)</b></p> <p>A new print head with a different resolution has been installed.</p> <p><b>Countermeasure (2)</b></p> <p>Install a print head with the same resolution as the old print head.</p>	<p> <a href="#">Replacing the Print Head</a></p>

Contact your SATO technical support if the error cannot be resolved.

 [Contact Information for When You Are in Trouble](#)

## Error Message 1028 (Gap Not Found)





When there is an error with the product, the error message appears on the screen.

Check the cause and countermeasure, and then take appropriate action.



To clear the error:

Press the  button (OFFLINE) or  button, or open/close the print head.

Cause and Countermeasure	Reference
<p><b>Cause (1)</b> Meandering media.</p> <p><b>Countermeasure (1)</b> Load the media correctly.</p>	<p> <a href="#">Loading Media</a></p>
<p><b>Cause (2)</b> A label is attached to the media sensor.</p> <p><b>Countermeasure (2)</b> Clean the media sensor.</p>	<p> <a href="#">Cleaning Using the Cleaning Kit</a></p>
<p><b>Cause (3)</b> The media sensor type is incorrect.</p> <p><b>Countermeasure (3)</b> Set the media sensor type which is compatible with the media you use.</p>	<p> <a href="#">Media Sensor Type</a></p>
<p><b>Cause (4)</b> The media sensor level is incorrect.</p>	<p> <a href="#">Calibrate</a></p>

Cause and Countermeasure	Reference
<b>Countermeasure (4)</b> Adjust the media sensor level.	

Contact your SATO technical support if the error cannot be resolved.



[Contact Information for When You Are in Trouble](#)

## Error Message 1029 (Cover Open)

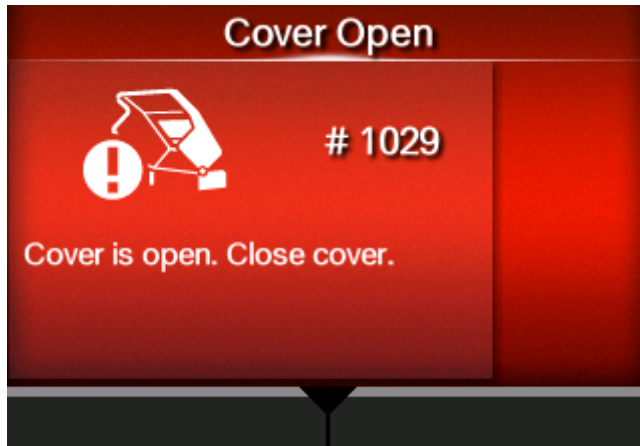

When there is an error with the product, the error message appears on the screen.

Check the cause and countermeasure, and then take appropriate action.



To clear the error:

Close the top cover.

Cause and Countermeasure	Reference
<p><b>Cause (1)</b> The top cover is open.</p> <p><b>Countermeasure (1)</b> Close the top cover.</p> <hr/> <p> • If you set [System] &gt; [Cover Open Sensor] to disabled, then the error screen does not appear even if the top cover is opened.</p> <hr/>	<p> <a href="#">Cover Open Sensor</a></p>
<p><b>Cause (2)</b> Cover open switch is malfunctioning.</p> <p><b>Countermeasure (2)</b> The cover open switch needs to be replaced. Contact your SATO technical support.</p>	<p> <a href="#">Contact Information for When You Are in Trouble</a></p>

## Error Message 1035 (I-mark Not Found)



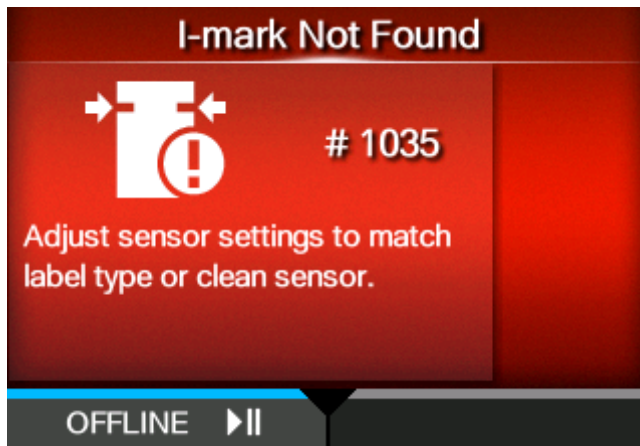

When there is an error with the product, the error message appears on the screen.

Check the cause and countermeasure, and then take appropriate action.



To clear the error:

Press the  button (OFFLINE) or  button, or open/close the print head.

Cause and Countermeasure	Reference
<p><b>Cause (1)</b> Meandering media.</p> <p><b>Countermeasure (1)</b> Load the media correctly.</p>	<p> <a href="#">Loading Media</a></p>
<p><b>Cause (2)</b> A label is attached to the media sensor.</p> <p><b>Countermeasure (2)</b> Clean the media sensor.</p>	<p> <a href="#">Cleaning Using the Cleaning Kit</a></p>
<p><b>Cause (3)</b> The media sensor type is incorrect.</p> <p><b>Countermeasure (3)</b> Set the media sensor type which is compatible with the media you use.</p>	<p> <a href="#">Media Sensor Type</a></p>
<p><b>Cause (4)</b> The media sensor level is incorrect.</p>	<p> <a href="#">Calibrate</a></p>

Cause and Countermeasure	Reference
<b>Countermeasure (4)</b> Adjust the media sensor level.	

Contact your SATO technical support if the error cannot be resolved.



[Contact Information for When You Are in Trouble](#)



## Error Message 1046 (EAP Authentication Error (EAP Failure))

When there is an error with the product, the error message appears on the screen.

Check the cause and countermeasure, and then take appropriate action.



To clear the error:

Change the Wi-Fi settings, or press the  button (OFFLINE) or  button.

Cause and Countermeasure	Reference
<b>Cause</b> EAP Authentication failure.	 <a href="#">EAP Conf.</a>
<b>Countermeasure</b> Use the correct Wi-Fi settings.	

Contact your SATO technical support if the error cannot be resolved.

 [Contact Information for When You Are in Trouble](#)



## Error Message 1047 (EAP Authentication Error (EAP Timeout))

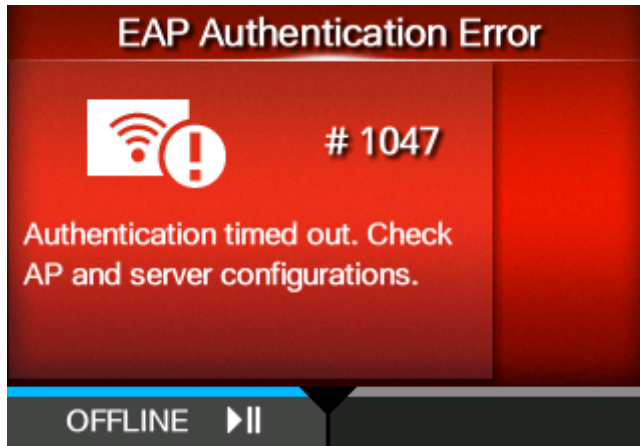

When there is an error with the product, the error message appears on the screen.

Check the cause and countermeasure, and then take appropriate action.



To clear the error:

Press the  button (OFFLINE) or  button.

Cause and Countermeasure	Reference
<p><b>Cause</b></p> <p>EAP Authentication failure.</p> <hr/> <p> • This error occurs when authentication with the EAP authentication server times out. This error will not occur if the connection to the access point is not established.</p> <hr/> <p><b>Countermeasure</b></p> <p>Use the correct Access Point (AP) and authentication server settings.</p>	<p> <a href="#">EAP Conf.</a></p>

Contact your SATO technical support if the error cannot be resolved.

 [Contact Information for When You Are in Trouble](#)

## Error Message 1065 (Printer Overheated)

When there is an error with the product, the error message appears on the screen.  
Check the cause and countermeasure, and then take appropriate action.



To clear the error:

Stop the operation of the product to let the temperature decrease.

### Cause and Countermeasure

#### Cause

The temperature of the product has exceeded its tolerance value.

#### Countermeasure

Stop the operation of the product to let the temperature decrease.

Contact your SATO technical support if the error cannot be resolved.

 [Contact Information for When You Are in Trouble](#)



## Error Message 1068 (WLAN Error)

When there is an error with the product, the error message appears on the screen.

Check the cause and countermeasure, and then take appropriate action.

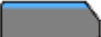

To clear the error:

Press the  button (OFFLINE) or  button.

Cause and Countermeasure	Reference
<p><b>Cause</b></p> <p>The wireless LAN module is damaged.</p> <p><b>Countermeasure</b></p> <p>The wireless LAN module needs to be replaced. Contact your SATO technical support.</p>	<p> <a href="#">Contact Information for When You Are in Trouble</a></p>

## Error Message 1073 (RFID Undetected) (S84NX Only)

When there is an error with the product, the error message appears on the screen.

Check the cause and countermeasure, and then take appropriate action.

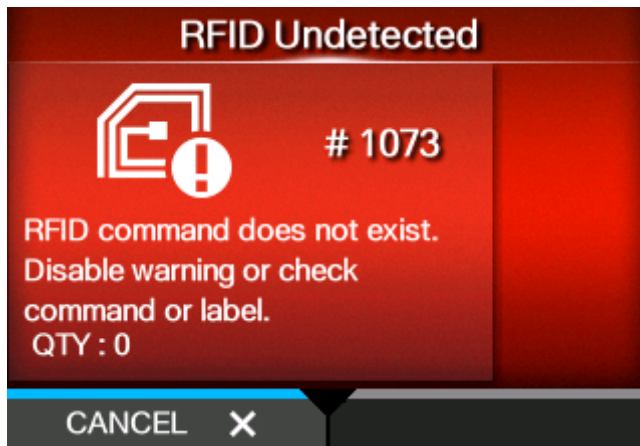

To clear the error:

Press the  button (CANCEL) or open/close the print head.

Cause and Countermeasure	Reference
<p><b>Cause</b></p> <p>With [RFID Undetected Warning] enabled and RFID tag loaded, the items received do not contain an RFID issue command.</p> <p><b>Countermeasure</b></p> <ul style="list-style-type: none"><li>◦ Add an RFID issue command to the print job.</li><li>◦ Set [RFID Undetected Warning] to [Disable].</li><li>◦ Replace with normal media.</li></ul>	<p> <a href="#">RFID Undetected Warning</a></p>

Contact your SATO technical support if the error cannot be resolved.

 [Contact Information for When You Are in Trouble](#)



## Error Message 1075 (NFC Error)

When there is an error with the product, the error message appears on the screen.

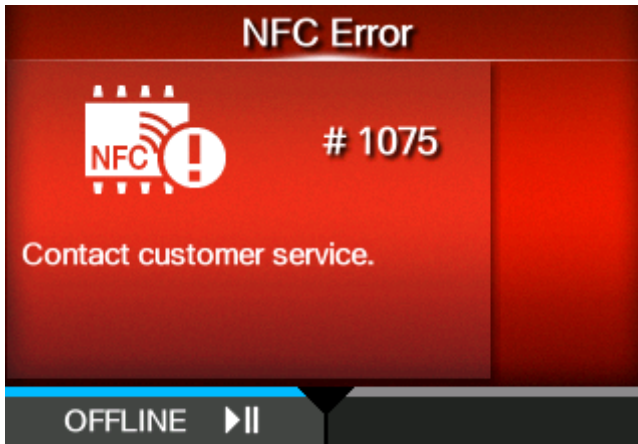
Check the cause and countermeasure, and then take appropriate action.

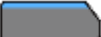

To clear the error:

Press the  button (OFFLINE) or  button.

Cause and Countermeasure	Reference
<p><b>Cause</b></p> <p>The NFC module is not operating correctly.</p> <p><b>Countermeasure</b></p> <p>A replacement of the NFC module is required. Contact your SATO technical support.</p>	<p> <a href="#">Contact Information for When You Are in Trouble</a></p>



## Error Message 1076 (Invalid command in NFC)

When there is an error with the product, the error message appears on the screen.

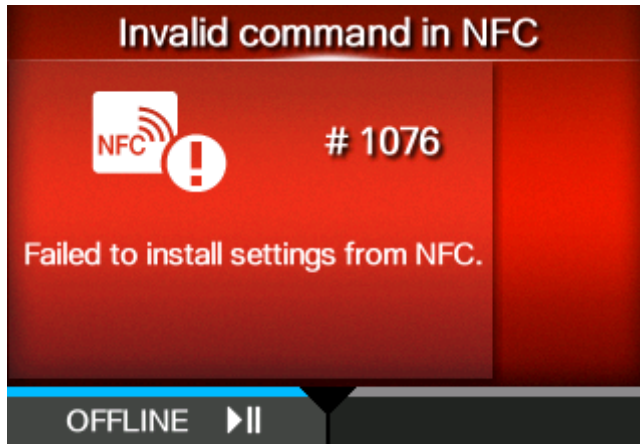
Check the cause and countermeasure, and then take appropriate action.



To clear the error:

Press the  button (OFFLINE) or  button.

### Cause and Countermeasure

#### Cause

A command error occurs and the settings are not saved correctly.

#### Countermeasure

Check the command.

Contact your SATO technical support if the error cannot be resolved.

 [Contact Information for When You Are in Trouble](#)

## Error Message 1077 (Barcode Reader Connection Error)

When there is an error with the product, the error message appears on the screen.

Check the cause and countermeasure, and then take appropriate action.

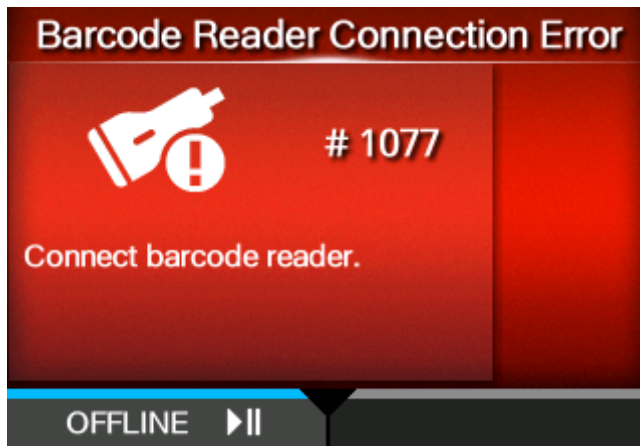

To clear the error:

Connect the barcode checker, or press the  button (OFFLINE) or  button.

Cause and Countermeasure	Reference
<p><b>Cause</b></p> <ul style="list-style-type: none"><li>◦ Could not check the connection of the barcode checker.</li><li>◦ Communication between the barcode checker and the product fails.</li></ul> <p><b>Countermeasure</b></p> <p>Check the barcode checker, and connect it correctly.</p> <p>If you do not use the barcode check function, disable the barcode check mode.</p>	<p> <a href="#">Mode</a></p>

Contact your SATO technical support if the error cannot be resolved.

 [Contact Information for When You Are in Trouble](#)



## Error Message 1078 (Barcode Reading Error)

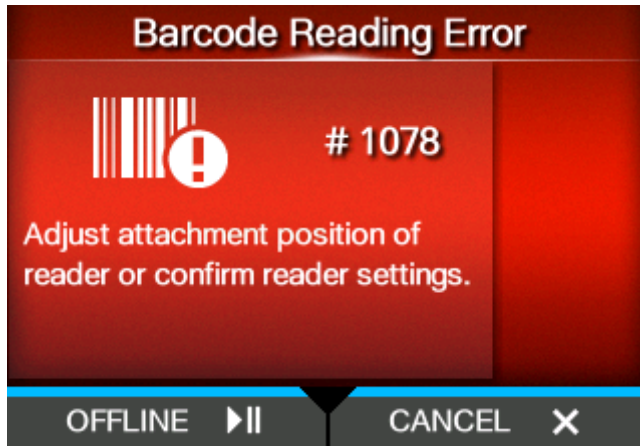

When there is an error with the product, the error message appears on the screen.

Check the cause and countermeasure, and then take appropriate action.

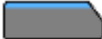

To clear the error:

Press the  button (OFFLINE) or  button, or  button (CANCEL).

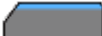
- Press the  button (OFFLINE) or  button to change to Offline mode while keeping the print job.
- Press the  button (CANCEL) to cancel the print job and change to Offline mode.

Cause and Countermeasure	Reference
<p><b>Cause</b></p> <p>Could not read the barcode correctly.</p> <p><b>Countermeasure</b></p> <ul style="list-style-type: none"><li>◦ Check the layout for printing.</li><li>◦ Check the barcode checker position and its settings.</li></ul>	<p> <a href="#">Configuring Optional Barcode Check Function</a></p>

Contact your SATO technical support if the error cannot be resolved.

 [Contact Information for When You Are in Trouble](#)



## Error Message 1079 (Barcode Reading Error (Checking Start Position Abnormality))

When there is an error with the product, the error message appears on the screen.

Check the cause and countermeasure, and then take appropriate action.



To clear the error:

Press the  button (OFFLINE) or  button. The product changes to Offline mode while keeping the print job.

Cause and Countermeasure	Reference
<p><b>Cause</b></p> <p>A value larger than the loaded media length is specified for checking start position.</p> <p><b>Countermeasure</b></p> <ul style="list-style-type: none"> <li>◦ Check the layout for printing.</li> <li>◦ Set a value smaller than the loaded media length for checking start position.</li> </ul>	<p> <a href="#">Start Position</a></p>

Contact your SATO technical support if the error cannot be resolved.

 [Contact Information for When You Are in Trouble](#)

## Error Message 1080 (Barcode Comparison Error)

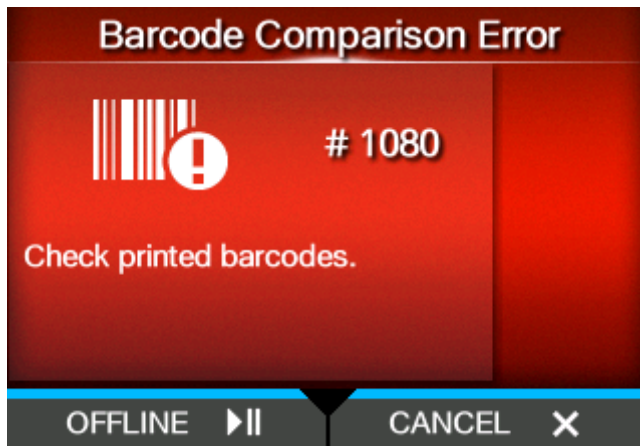

When there is an error with the product, the error message appears on the screen.

Check the cause and countermeasure, and then take appropriate action.

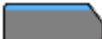

To clear the error:

Press the  button (OFFLINE) or  button, or  button (CANCEL).

- Press the  button (OFFLINE) or  button to change to Offline mode while keeping the print job.
- Press the  button (CANCEL) to cancel the print job and change to Offline mode.

Cause and Countermeasure	Reference
<p><b>Cause</b></p> <p>The read result of the barcode does not match the print data.</p> <p><b>Countermeasure</b></p> <ul style="list-style-type: none"><li>◦ Check the layout for printing.</li><li>◦ Check the barcode checker position and its settings.</li></ul>	<p> <a href="#">Configuring Optional Barcode Check Function</a></p>

Contact your SATO technical support if the error cannot be resolved.

 [Contact Information for When You Are in Trouble](#)



## Error Message 1099 (Config Warning)



When there is an error with the product, the error message appears on the screen.

Check the cause and countermeasure, and then take appropriate action.



To clear the error:

Press the  button (OFFLINE) or  button.

Cause and Countermeasure	Reference
<p><b>Cause</b></p> <p>The power was cut off in an inappropriate way, such as the power cord was pulled out while the power was on.</p> <p><b>Countermeasure</b></p> <ul style="list-style-type: none"><li>◦ Power off the product correctly.</li><li>◦ Reset the product in the Settings menu.</li></ul>	<p> <a href="#">Powering Off the Product</a></p> <p> <a href="#">The Product's Settings Menu</a></p>

Contact your SATO technical support if the error cannot be resolved.

 [Contact Information for When You Are in Trouble](#)

## Error Message 1114 (Tag not Found) (S84NX Only)

When there is an error with the product, the error message appears on the screen.

Check the cause and countermeasure, and then take appropriate action.

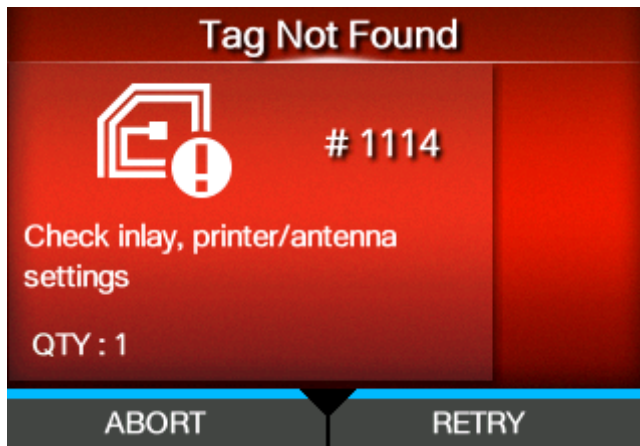

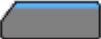
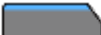

To clear the error:

Press the  button (RETRY), and then execute the retry/release operation set in [Retry Mode], or press the  button (ABORT).

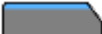
 [Retry Mode](#)

To cancel an entire print job, open and close the top cover to switch the product to Offline mode, and then press the  button (CANCEL).

Cause and Countermeasure	Reference
<b>Cause</b> Did not find the tag, or failed to read the tag.	 <a href="#">RFID Settings (S84NX Only)</a>
<b>Countermeasure</b> Confirm the inlay and check the product and antenna settings.	 <a href="#">RFID (S84NX Only)</a>

Contact your SATO technical support if the error cannot be resolved.

 [Contact Information for When You Are in Trouble](#)



- You cannot use an RFID tag that has caused an RFID tag error. An error message is printed on the RFID tag that caused the error.

## Error Message 1115 (Write Tag Error) (S84NX Only)

When there is an error with the product, the error message appears on the screen.

Check the cause and countermeasure, and then take appropriate action.

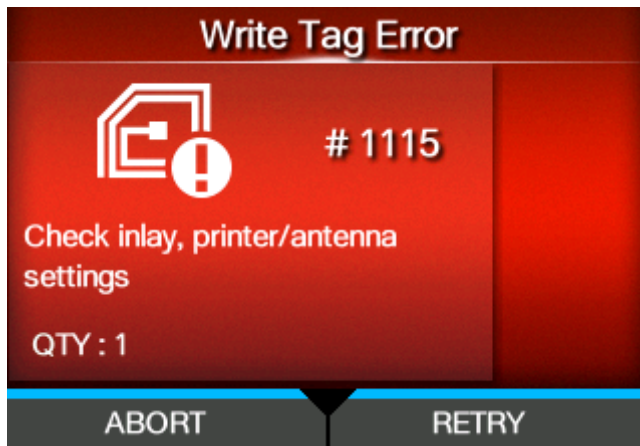

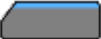
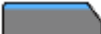

To clear the error:

Press the  button (RETRY), and then execute the retry/release operation set in [Retry Mode], or press the  button (ABORT).

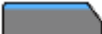
 [Retry Mode](#)

To cancel an entire print job, open and close the top cover to switch the product to Offline mode, and then press the  button (CANCEL).

Cause and Countermeasure	Reference
<b>Cause</b> Failed to write the inlay.	 <a href="#">RFID Settings (S84NX Only)</a>
<b>Countermeasure</b> Confirm the inlay and check the product and antenna settings.	 <a href="#">RFID (S84NX Only)</a>

Contact your SATO technical support if the error cannot be resolved.

 [Contact Information for When You Are in Trouble](#)



- You cannot use an RFID tag that has caused an RFID tag error. An error message is printed on the RFID tag that caused the error.

## Error Message 1116 (Failed to Read the Tag Data) (S84NX Only)

When there is an error with the product, the error message appears on the screen.

Check the cause and countermeasure, and then take appropriate action.

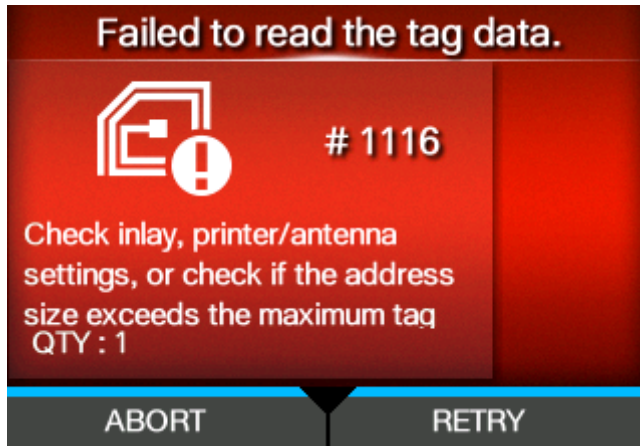



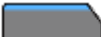

To clear the error:

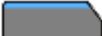
Press the  button (RETRY), and then execute the retry/release operation set in [Retry Mode], or press the  button (ABORT).

 [Retry Mode](#)

To cancel an entire print job, open and close the top cover to switch the product to Offline mode, and then press the  button (CANCEL).

Cause and Countermeasure	Reference
<p><b>Cause (1)</b></p> <p>Failed to read the tag by using the tag data print &lt;TU&gt; command.</p> <p><b>Countermeasure (1)</b></p> <ul style="list-style-type: none"> <li>Confirm the inlay and check the product and antenna settings.</li> <li>Confirm that an address that exceeds the inlay volume has not been specified.</li> </ul>	<p> <a href="#">RFID Settings (S84NX Only)</a></p> <p> <a href="#">RFID (S84NX Only)</a></p>
<p><b>Cause (2)</b></p> <p>Failed to replace the loaded tag.</p> <p><b>Countermeasure (2)</b></p> <p>Confirm the inlay and check the product and antenna settings.</p>	<p> <a href="#">RFID Settings (S84NX Only)</a></p> <p> <a href="#">RFID (S84NX Only)</a></p>

Contact your SATO technical support if the error cannot be resolved.



## [Contact Information for When You Are in Trouble](#)

---



- You cannot use an RFID tag that has caused an RFID tag error. An error message is printed on the RFID tag that caused the error.
-



## Error Message 1118 (Write/Read Values Are not Consistent) (S84NX Only)

When there is an error with the product, the error message appears on the screen.

Check the cause and countermeasure, and then take appropriate action.

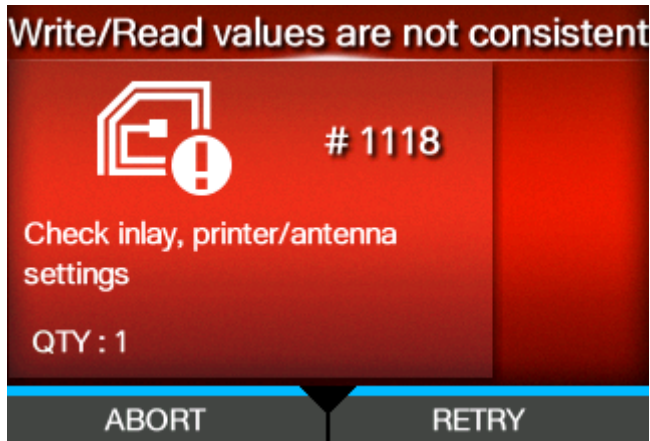

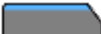

To clear the error:

Press the  button (RETRY), and then execute the retry/release operation set in [Retry Mode], or press the  button (ABORT).

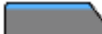
 [Retry Mode](#)

To cancel an entire print job, open and close the top cover to switch the product to Offline mode, and then press the  button (CANCEL).

Cause and Countermeasure	Reference
<p><b>Cause</b></p> <p>The written value and read value do not match.</p> <p><b>Countermeasure</b></p> <p>Confirm the inlay and check the product and antenna settings.</p>	<p> <a href="#">RFID Settings (S84NX Only)</a></p> <p> <a href="#">RFID (S84NX Only)</a></p>

Contact your SATO technical support if the error cannot be resolved.

 [Contact Information for When You Are in Trouble](#)



- You cannot use an RFID tag that has caused an RFID tag error. An error message is printed on the RFID tag that caused the error.

## Error Message 1119 (Failed to Lock the Data) (S84NX Only)

When there is an error with the product, the error message appears on the screen.

Check the cause and countermeasure, and then take appropriate action.

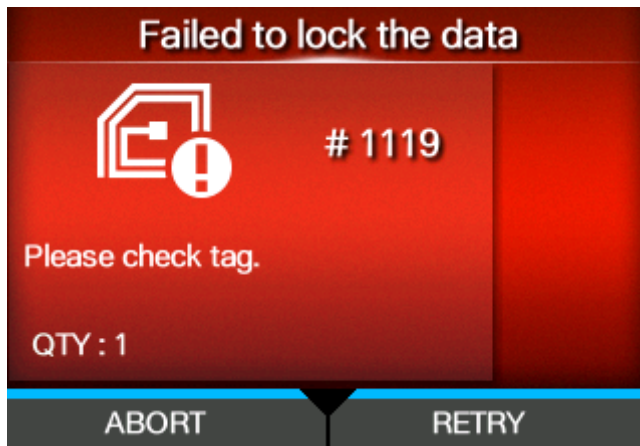

To clear the error:

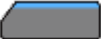
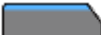
Press the  button (RETRY), and then execute the retry/release operation set in [Retry Mode], or press the  button (ABORT).

 [Retry Mode](#)

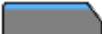
To cancel an entire print job, open and close the top cover to switch the product to Offline mode, and then press the  button (CANCEL).

### Cause and Countermeasure

#### Cause

Failed to lock the inlay.

#### Countermeasure

Check the inlay.

Contact your SATO technical support if the error cannot be resolved.

 [Contact Information for When You Are in Trouble](#)



- You cannot use an RFID tag that has caused an RFID tag error. An error message is printed on the RFID tag that caused the error.

## Error Message 1121 (Multiple Tags Are Detected) (S84NX Only)

When there is an error with the product, the error message appears on the screen.

Check the cause and countermeasure, and then take appropriate action.

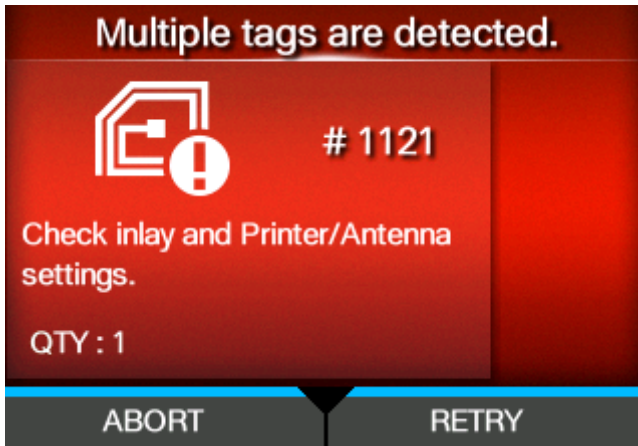

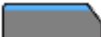

To clear the error:

Press the  button (RETRY), and then execute the retry/release operation set in [Retry Mode], or press the  button (ABORT).

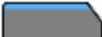
 [Retry Mode](#)

To cancel an entire print job, open and close the top cover to switch the product to Offline mode, and then press the  button (CANCEL).

Cause and Countermeasure	Reference
<b>Cause</b> Multiple inlays captured at same time.	 <a href="#">RFID Settings (S84NX Only)</a>
<b>Countermeasure</b> Confirm the inlay and check the product and antenna settings.	 <a href="#">RFID (S84NX Only)</a>

Contact your SATO technical support if the error cannot be resolved.

 [Contact Information for When You Are in Trouble](#)





- You cannot use an RFID tag that has caused an RFID tag error. An error message is printed on the RFID tag that caused the error.

## Error Message 1123 (Write Tag Error) (S84NX Only)

When there is an error with the product, the error message appears on the screen.  
Check the cause and countermeasure, and then take appropriate action.



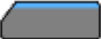

To clear the error:

Press the  button (RETRY), and then execute the retry/release operation set in [Retry Mode], or press the  button (ABORT).

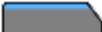
 [Retry Mode](#)

To cancel an entire print job, open and close the top cover to switch the product to Offline mode, and then press the  button (CANCEL).

Cause and Countermeasure	Reference
<p><b>Cause (1)</b> Tried to write to an inlay that was write-locked.</p> <p><b>Countermeasure (1)</b> Use tags that are not locked.</p>	-
<p><b>Cause (2)</b> Tried to write to an inlay when the writing power is low.</p> <p><b>Countermeasure (2)</b> Adjust [Write Power]/[Read Power].</p>	<p> <a href="#">Write Power</a></p> <p> <a href="#">Read Power</a></p>

Contact your SATO technical support if the error cannot be resolved.

 [Contact Information for When You Are in Trouble](#)



- You cannot use an RFID tag that has caused an RFID tag error. An error message is printed on the RFID tag that caused the error.

## Error Message 1126 (Not Enough Power) (S84NX Only)

When there is an error with the product, the error message appears on the screen.

Check the cause and countermeasure, and then take appropriate action.



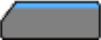
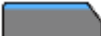

To clear the error:

Press the  button (RETRY), and then execute the retry/release operation set in [Retry Mode], or press the  button (ABORT).

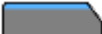
 [Retry Mode](#)

To cancel an entire print job, open and close the top cover to switch the product to Offline mode, and then press the  button (CANCEL).

Cause and Countermeasure	Reference
<p><b>Cause</b></p> <p>The [RSSI Filter] function is enabled, and the RSSI value of the inlay is lower than the values set in [Threshold Value].</p> <p><b>Countermeasure</b></p> <ul style="list-style-type: none"> <li>◦ Check the tags. Or, check the [Threshold Value] settings.</li> <li>◦ Adjust [Write Power]/[Read Power].</li> </ul>	<p> <a href="#">Threshold Value</a></p> <p> <a href="#">Write Power</a></p> <p> <a href="#">Read Power</a></p>

Contact your SATO technical support if the error cannot be resolved.

 [Contact Information for When You Are in Trouble](#)



- You cannot use an RFID tag that has caused an RFID tag error. An error message is printed on the RFID tag that caused the error.

## Error Message 1136 (Label Sensor Cover Open)

When there is an error with the product, the error message appears on the screen.

Check the cause and countermeasure, and then take appropriate action.



To clear the error:

Lock the feed roller and media sensor assembly.

### Cause and Countermeasure

#### Cause

- The feed roller and media sensor assembly are unlocked.
- The sensor for detecting the open/close status of the media sensor assembly is defective.

#### Countermeasure

Unlock the feed roller and media sensor assembly once, and then lock them again.

1. Pull the feed lock latch (1) to unlock the feed roller and media sensor assembly (2).

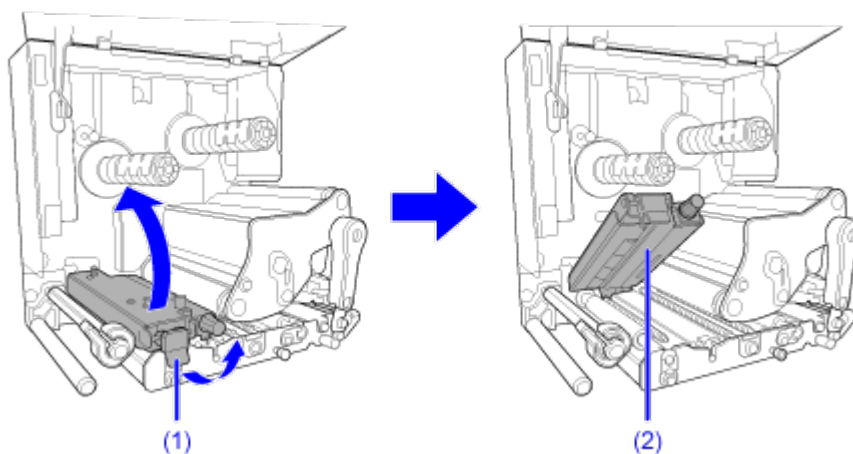

2. Press the feed roller and media sensor assembly (2) down until the feed lock latch (1) is locked.

## Cause and Countermeasure

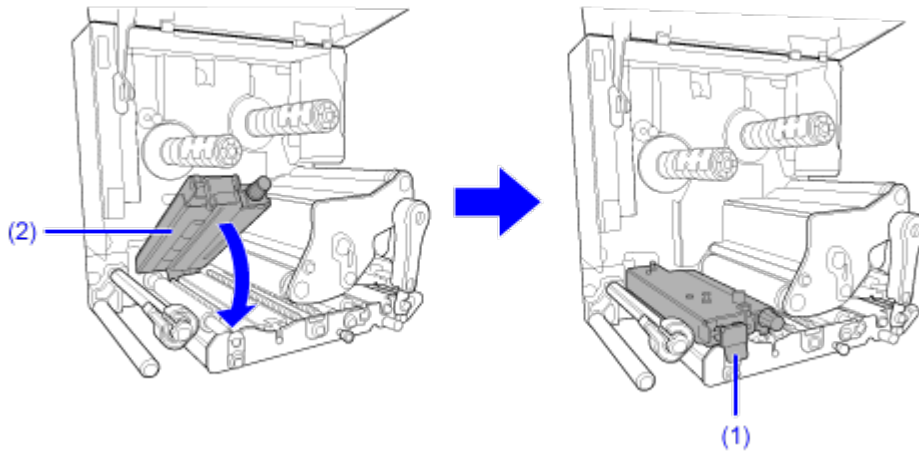

Contact your SATO technical support if the error cannot be resolved.

 [Contact Information for When You Are in Trouble](#)



## Error Message 1141 (Printing was aborted halfway)

When there is an error with the product, the error message appears on the screen.

Check the cause and countermeasure, and then take appropriate action.



To clear the error:

Press the  button (OFFLINE) or  button to switch to Offline mode.



Then, press the  button to feed and eject the labels that have been printed halfway through.

### Cause and Countermeasure

#### Cause

In dispense & print mode, printing was interrupted by a cancel operation or error.

#### Countermeasure

Press the  button (OFFLINE) or  button to switch to Offline mode, and then press the  button to feed and eject the labels that have finished printing part way.

Contact your SATO technical support if the error cannot be resolved.

 [Contact Information for When You Are in Trouble](#)



## Error Message Indication and Operating Procedure When the SOS (SATO Online Services) Is Enabled (SOS users only)



---

The SOS (SATO Online Services) icon appears in the error message when SOS is enabled.

If you select the SOS icon, a QR code containing the error information and the contact telephone number appears.

- Press the  button.



- If the icon of the guidance videos also appears, select the SOS icon using the  /  button, and then press the  button.



A screen with QR code, phone number, serial number, and error number appears after selecting the SOS icon and pressing the  button.

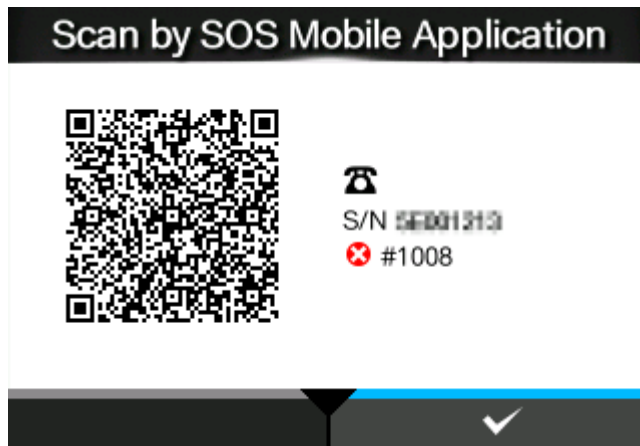

Scan the QR code with the specialized SOS application from a tablet device or smartphone. After scanning the QR code, the menu for the specialized SOS application appears.

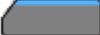
Press the  button to return to the error message screen.

Also, the product information can be acquired via NFC and sent to the SOS cloud.

## Messages for Provisioning Errors When SOS (SATO Online Services) is Enabled (SOS users only)

A provisioning error occurs if authentication with the server fails while adding the product to SOS. The messages differ depending on the cause. Check the following countermeasures, and then take appropriate action.

To clear the error:

Press the  button or  button.

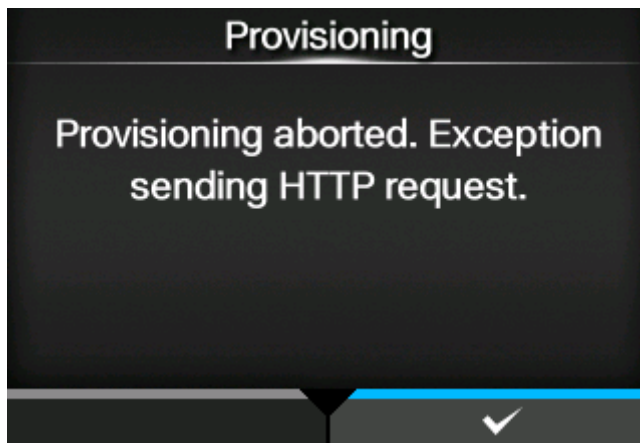

- Normally, it is not necessary to restart the product.

Return Code	Message	Countermeasure
400	RetCode:400 Failed sending data. Please set the SOS Mode to Disabled, and then set it again.	If resetting the SOS mode does not resolve the error, contact your nearest SATO reseller.
403	RetCode:403 Unauthorized. Please set the SOS Mode to Disabled, and then set it again.	If resetting the SOS mode does not resolve the error, contact your nearest SATO reseller.
405	RetCode:405 Unknown Model.	Contact your nearest SATO reseller.
406	RetCode:406 This serial has not been registered for use with SOS. Please check the registration.	Confirm the registration with the administrator of your SOS account.
407	RetCode: 407 There is a problem with the proxy server settings. Please check the settings.	If changing the proxy settings does not resolve the error, confirm with your administrator.
408	RetCode: 408 HTTPS request timed out.	Confirm the proxy settings or the network communication status.  If the error occurs even if the communication status is normal, contact your nearest SATO reseller.

Messages for Provisioning Errors When SOS (SATO Online Services) is Enabled (SOS users only)

Return Code	Message	Countermeasure
409	RetCode:409 No serial number is registered with this printer. Please check the settings.	Contact your nearest SATO reseller.
500	RetCode:500 SOS system error. Please contact the help desk.	A system error has occurred with the SOS or the proxy server. Wait for a while and contact your nearest SATO reseller if the error cannot be resolved.
503	RetCode:503 SOS Server Maintenance.	Cannot be used during maintenance. Please wait until the maintenance is finished.
-	Unknown error. Please contact the help desk.	Wait for a while and contact your nearest SATO reseller if the error cannot be resolved.

## Contact Information for When You Are in Trouble

---

### Contact Us

Access the following site to send us your questions or comments.



<https://www.sato-global.com/contact/>

# Product Specifications

## Hardware

### Dimensions and Weight

Item	S84NX	S86NX
External dimensions	245 mm (9.65") (width) x 408 mm (16.06") (depth) x 300 mm (11.81") (height) (excludes projections)	245 mm (9.65") (width) x 463 mm (18.23") (depth) x 300 mm (11.81") (height) (excludes projections)
Weight	<p><b>Direct thermal model</b></p> <p>Approximately 12.7 kg (27.99 lbs.) (excludes media and options)</p> <p><b>Combined direct thermal/thermal transfer model</b></p> <p>Approximately 14.1 kg (31.08 lbs.) (excludes media, ribbon and options)</p>	<p><b>Direct thermal model</b></p> <p>Approximately 14.0 kg (30.86 lbs.) (excludes media and options)</p> <p><b>Combined direct thermal/thermal transfer model</b></p> <p>Approximately 15.5 kg (34.17 lbs.) (excludes media, ribbon and options)</p>

### Power Supply

Item	S84NX	S86NX
Input Voltage	AC 100 - 240 V $\pm$ 10% (Full-range)	
Frequency	50 / 60 Hz	
Power Consumption	<p>Input voltage conditions: AC 230 V, 50 Hz</p> <p><b>At peak</b></p> <p>267 VA / 226 W (print ratio 30 %)</p> <p><b>Standby</b></p> <p>52 VA / 25 W</p>	<p>Input voltage conditions: AC 230 V, 50 Hz</p> <p><b>At peak</b></p> <p>359 VA / 334 W (print ratio 30 %)</p> <p><b>Standby</b></p> <p>52 VA / 24 W</p>

### Processing

Item	S84NX	S86NX
Flash ROM	<p><b>CPU1</b></p> <p>2 GB</p>	

Item	S84NX	S86NX
	<b>CPU2</b> 4 MB	
SDRAM	<b>CPU1</b> 256 MB <b>CPU2</b> 64 MB	
User Registration Area	Maximum 576 MB	
Receive Buffer	<b>Buffer full</b> 2.95 MB <b>Buffer near full</b> Occurrence: 2 MB, Release: 1 MB	

### Operation

Item	S84NX	S86NX
Display	TFT color 3.5-inch (88.9 mm)	
LED	<b>STATUS</b> Blue/Red	
Display Language	English / German / French / Spanish / Italian / Portuguese / Brazilian Portuguese / Czech / Danish / Dutch / Finnish / Greek / Hungarian / Norwegian / Polish / Romanian / Russian / Slovak / Swedish / Turkish / Chinese (Simplified) / Chinese (Traditional) / Korean / Japanese / Arabic / Thai / Vietnamese / Persian / Indonesian / Hindi / Bulgarian	

### Environmental Conditions

Item	S84NX	S86NX
Operating Temperature	-5 to 40 °C (23 to 104 °F)	
Storage Temperature	-20 to 60 °C (-4 to 140 °F)	
Operating Humidity	15 to 85% RH (Non-condensing)	

Item	S84NX	S86NX
Storage Humidity (without supply products)	15 to 90% RH (Non-condensing)	

## Print

Item	S84NX	S86NX
Print Method	Direct thermal, combined direct thermal/thermal transfer	
Resolution (Head Density)	<ul style="list-style-type: none"> <li>• 203 dpi (8 dots/mm)</li> <li>• 305 dpi (12 dots/mm)</li> <li>• 609 dpi (24 dots/mm)</li> </ul>	<ul style="list-style-type: none"> <li>• 203 dpi (8 dots/mm)</li> <li>• 305 dpi (12 dots/mm)</li> </ul>
Print Speed	<p><b>203 dpi</b> 4 to 16 inches/sec (101.6 to 406.4 mm/sec)</p> <p><b>305 dpi</b> 4 to 14 inches/sec (101.6 to 355.6 mm/sec)</p> <p><b>609 dpi</b> 2 to 6 inches/sec (50.8 to 152.4 mm/sec)</p>	<p><b>203 dpi</b> 4 to 14 inches/sec (101.6 to 355.6 mm/sec)</p> <p><b>305 dpi</b> 4 to 12 inches/sec (101.6 to 304.8 mm/sec)</p>
Non-printable Area	<p>Pitch direction (Excludes liner)</p> <p><b>Top</b> 1.5 mm (0.06")</p> <p><b>Bottom</b> 1.5 mm (0.06")</p> <p>Width direction (Excludes liner)</p> <p><b>Left</b> 1.5 mm (0.06")</p> <p><b>Right</b> 1.5 mm (0.06")</p> <hr/> <p> • (S84NX only) For RFID models, printing around the chip or on the antenna may be limited by the layout.</p> <hr/>	



Item	S84NX	S86NX
Printable Area	<p><b>203 dpi</b> Length 2500 mm (98.42") x Width 104 mm (4.09")</p> <p><b>305 dpi</b> Length 1500 mm (59.05") x Width 104 mm (4.09")</p> <p><b>609 dpi</b> Length 400 mm (15.75") x Width 104 mm (4.09")</p>	<p><b>203 dpi</b> Length 2500 mm (98.42") x Width 167.5 mm (6.59")</p> <p><b>305 dpi</b> Length 1500 mm (59.05") x Width 167.5 mm (6.59")</p>
Print End Position	<p><b>203 dpi (1 dot = 0.125 mm (0.0049"))</b> 1 to 20000 dots</p> <p><b>305 dpi (1 dot = 0.083 mm (0.0033"))</b> 1 to 18000 dots</p> <p><b>609 dpi (1 dot = 0.042 mm (0.0017"))</b> 1 to 9600 dots</p>	<p><b>203 dpi (1 dot = 0.125 mm (0.0049"))</b> 1 to 20000 dots</p> <p><b>305 dpi (1 dot = 0.083 mm (0.0033"))</b> 1 to 18000 dots</p>
Print Darkness	<p><b>Darkness level</b> 1 to 10</p> <p><b>Darkness range</b> A</p>	

### Sensors

Item	S84NX	S86NX
I-mark (Reflective Type)	<p><b>Position</b> Fixed</p> <p><b>Sensitivity</b> Adjustable (auto and manual)</p>	
Gap (Transmissive Type)	<p><b>Position</b> Adjustable</p> <p><b>Sensitivity</b> Adjustable (auto and manual)</p>	

Item	S84NX	S86NX
Head Open	Fixed	
Paper End Sensor	Detect with I-mark sensor or Gap sensor	
Ribbon End/Ribbon Near End	Fixed	
Cover Open	Fixed	
Label Sensor Cover Open	Fixed	



- Specifications are subject to change without notice.
-

# Interface

---

## Supported Interfaces

For data communication with the host, the product supports the following interfaces.

### Standard

- USB Interface (Type B)
- LAN Interface (Ethernet)
- NFC Interface
- USB Interface (Type A) x 2
- RS-232C Interface (DB 9 pins, female)
- External Signal (EXT) Interface (D-sub 25 pins)

### Option

- Wireless LAN Interface

### RFID (S84NX only)

#### UHF (920 MHz)

ISO/IEC 18000-6 Type C Gen2



- Do not connect or disconnect the interface cables (or use a switch box) with power supplied to either the product or host. This may cause damage to the interface circuitry in the product or host and is not covered by warranty.



- Wireless LAN is an optional interface.
  - You cannot use the wireless LAN interface and LAN interface at a time.
  - You can set the interface settings of the product through [Interface] in the [Settings] menu.
-

## USB Interface

This interface complies with the USB 2.0 standard.

Install the USB driver to the computer before use.

Basic Specifications	
Connector	USB Type B connector
Protocol	<ul style="list-style-type: none"> <li>STATUS4</li> <li>STATUS5</li> </ul>
Power Supply	BUS Power through cable

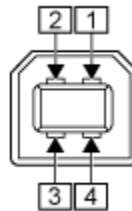

Pin Assignments	
Pin No.	Description
1	VBus
2	-Data
3	+Data
4	GND

Cable Specifications	
Cable Connector	USB Type B connector
Cable Length	5 m (16.4 feet) or less



• Specifications are subject to change without notice.

## LAN Interface

Basic Specifications	
Connector	RJ-45 Receptacle
Protocol	<ul style="list-style-type: none"><li>• Status3</li><li>• Status4</li><li>• Status5</li></ul>
IP Address	<ul style="list-style-type: none"><li>• IPv4</li><li>• IPv6</li></ul>
Subnet Mask / Prefix Length	<ul style="list-style-type: none"><li>• IPv4</li><li>• IPv6</li></ul>
Gateway Address	<ul style="list-style-type: none"><li>• IPv4</li><li>• IPv6</li></ul>

Cable Specifications	
Cable	10BASE-T/100BASE-TX Category 5 or better
Cable Length	100 m (328 feet) or less

Software Specifications	
Supported Protocol	TCP/IP
Network Layer	<ul style="list-style-type: none"><li>• IP</li><li>• ICMP</li></ul>
Session Layer	<ul style="list-style-type: none"><li>• TCP</li><li>• UDP</li></ul>
Application Layer	<ul style="list-style-type: none"><li>• LPR</li><li>• FTP</li><li>• DHCP</li><li>• HTTP/HTTPS</li><li>• SNMP</li><li>• NTP</li></ul>



• Specifications are subject to change without notice.

---

## NFC Interface

This interface complies with the NFC Forum Type 2 Tag.



- Specifications are subject to change without notice.
-

## RS-232C Interface

This interface complies with the RS-232C standard.

Basic Specifications	
Asynchronous ASCII	Half-duplex communication Bi-directional communication
Data Transmission Rate	2400, 4800, 9600, 19200, 38400, 57600, 115200 bps
Transmission Form	Start, b1, b2, b3, b4, b5, b6, b7, b8, Stop   • "b8" will be omitted if using 7 bit oriented.
Data Length	7 or 8 bits (initial value)
Stop Bit	1 (initial value) or 2 bits
Parity Bit	ODD, EVEN, NONE (initial value)
Codes Used	<b>ASCII Character Codes</b> 7 bits <b>Graphics</b> 8 bits
Control Codes	STX (02H), ETX (03H), ACK (06H), NAK (15H)
Connector	DB-9 Female or equivalent
Signal Level	High = +5 to +12 V, Low = -5 to -12 V
Protocol	<ul style="list-style-type: none"> <li>• READY/BUSY</li> <li>• XON/XOFF</li> <li>• STATUS3</li> <li>• STATUS4</li> <li>• STATUS5</li> </ul>

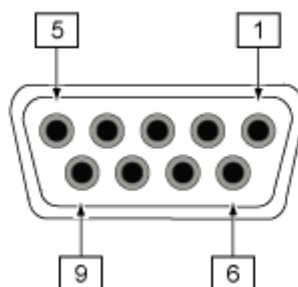

Connector Pin Specifications		
Pin No.	I/O	Description
1	-	Data Carrier Detect
2	Input	Receive Data
3	Output	Transmit Data
4	Output	Data Terminal Ready
5	Reference	Signal Ground
6	Input	Data Set Ready
7	Output	Request To Send
8	Input	Clear To Send
9	-	Not connected

Cable Specifications	
Cable Connector	DB-9 Male or equivalent
Cable Length	5 m (16.4 feet) or less



- When using the READY/BUSY control, make sure that the product is in power on mode before you send the data from the host.
- With communication protocols such as XON/XOFF, STATUS3, STATUS4 or STATUS5, a receive buffer full error will occur when the received data is more than the receive buffer size (2.95 MB). When sending data, monitor the status of the product and keep the size of the data that is sent to less than 2.95 MB.
- A parity error is detected when an error occurs after receiving the start code <A> command.
- Specifications are subject to change without notice.



## External Signal (EXT) Interface

### Basic Specifications of External Signal (EXT) Interface

This interface is designed to connect the product with other peripherals.

Basic Specifications	
Connector	DB 25 pins, female Amphenol 14 pins, female (use with the optional 14-pin conversion cable)
Signal Levels	<p><b>Input (NPN/PNP connection shared)</b></p> <p>Input connector ON: <math>i_{in}</math> = approx. 0 mA (high impedance)</p> <p>Input connector OFF: <math>i_{in}</math> = approx. 2 to 20 mA (0 to 0.7 V)</p> <p><b>Output</b></p> <p>Output connector ON: <math>i_{out}</math> = approx. 80 mA</p> <p>Output connector OFF: <math>i_{out}</math> = approx. 0 mA</p>

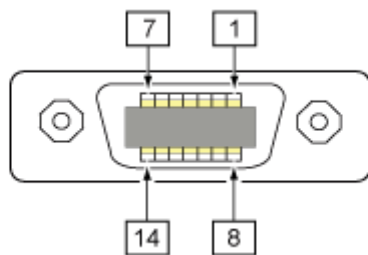
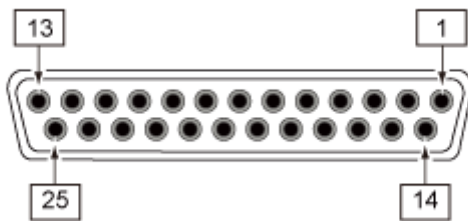

### Connector Pin Specifications of External Signal (EXT) Interface

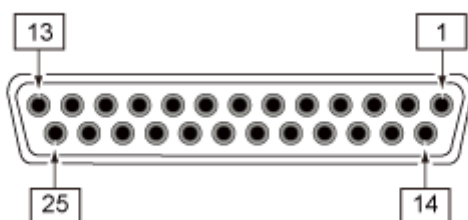

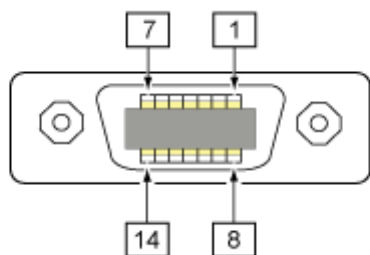

### Standard specifications

Pin No.		I/O	Description	Electric Conditions (Voltage, Current (Max))
25-pin	14-pin			
1	14	-	Frame Ground	-
2	-	-	Power source	+5 V 600 mA <sup>3</sup>
3	-	Output	<b>Home Position signal</b>  Outputs a signal when [Backfeed] in the [Printing] menu is set to [Controlled] and backfeed is done.	40 V 80 mA
4	4	Output	<b>Machine Error</b>  Outputs a low signal when an error, such as cover open, head error, or communication error, is detected.	40 V 80 mA
5	6	Output	<b>Print Done/Print End signal (PREND)</b>  Outputs a signal when the media print is completed.	40 V 80 mA
6	9	Output	<b>Print Ready signal</b>  Outputs a high signal when the product is in Online mode and ready for printing.	40 V 80 mA
7	-	Input <sup>2</sup>	<b>Label Near End signal</b>  The product becomes label near end status when a low signal is detected.	High: high impedance Low: more than -5 mA, 0 V
8	7	Input <sup>2</sup>	<b>Reprint signal (PRIN2)</b>  Prints the previously printed content again when a low signal is detected.	High: high impedance Low: more than -5 mA, 0 V

Pin No.		I/O	Description	Electric Conditions (Voltage, Current (Max))
25-pin	14-pin			
9	-	Input <sup>2</sup>	<b>Backfeed order signal (DISPENSE IN)</b> When [Backfeed] in the [Printing] menu is set to [Controlled], backfeed is performed when a low signal is detected.	High: high impedance Low: more than -5 mA, 0 V
10	-	Input <sup>2</sup>	Reserve	High: high impedance Low: more than -5 mA, 0 V
11	-	-	<b>OUT_COM</b> Ground of peripherals	-
12	13	-	Power source	+5 V 600 mA <sup>3</sup>
13	12	-	Power source	+24 V 2 A
14	2	-	<b>GND</b> Reference Signal Ground	-
15	2	-	<b>OUT_COM</b> Ground of peripherals	-
16	3	Output	<b>Ribbon End</b> Outputs a low signal when the ribbon end is detected.	40 V 80 mA
17	1	Output	<b>Paper End</b> Outputs a low signal when the paper end is detected.	40 V 80 mA
18	10	Output	<b>Ribbon Near End</b> Outputs a high signal when the ribbon near end is detected.	40 V 80 mA
19	-	Output	Reserve	40 V 80 mA

Pin No.		I/O	Description	Electric Conditions (Voltage, Current (Max))
25-pin	14-pin			
20	5	Input <sup>2</sup>	<b>Print Start signal (PRIN)</b> Prints one media when a low signal is detected.	High: high impedance Low: more than -5 mA, 0 V
21	11	Input <sup>2</sup>	<b>Feed signal</b> Media feeds when a low signal is detected.	High: high impedance Low: more than -5 mA, 0 V
22	-	Input <sup>2</sup>	Reserve	High: high impedance Low: more than -5 mA, 0 V
23	-	Input <sup>2</sup>	Reserve	High: high impedance Low: more than -5 mA, 0 V
24	13	Input	<b>IN_COM<sup>1</sup></b> Power supply from peripherals	5 V - 24 V or GND
25	-	-	<b>GND</b> Reference Signal Ground	-

<sup>1</sup> When using the 14-pin conversion cable, do not connect the power pin to "IN\_COM" pin. The "IN\_COM" pin is connected to 5 V in cable.

<sup>2</sup> These input signal terminals can be connected to the open collector input devices.

<sup>3</sup> If 25-pin is selected, the total output of Pin No. 2 and 12 will be 600 mA.

#### RFID specifications (S84NX only)

(S84NX only) For the RFID model, the signals indicated in bold text in the table below are settings that differ from the standard specifications.

Pin No.		I/O	Description	Electric Conditions (Voltage, Current (Max))
25-pin	14-pin			
1	14	-	Frame Ground	-
2	-	-	Power source	+5 V 600 mA <sup>3</sup>

Pin No.		I/O	Description	Electric Conditions (Voltage, Current (Max))
25-pin	14-pin			
3	-	Output	<b>Home Position signal</b> Outputs a signal when [Backfeed] in the [Printing] menu is set to [Controlled] and backfeed is done.	40 V 80 mA
4	4	Output	<b>Machine Error/RFID Error</b> <b>Outputs a low signal when an error, such as cover open, head error, or communication error, is detected.</b> <b>Or, outputs a low signal when an RFID system error occurs.</b>	40 V 80 mA
5	6	Output	<b>Print Done/Print End signal (PREND)</b> Outputs a signal when the media print is completed.	40 V 80 mA
6	9	Output	<b>Print Ready signal</b> Outputs a high signal when the product is in Online mode and ready for printing.	40 V 80 mA
7	-	Input <sup>2</sup>	<b>Label Near End signal</b> The product becomes label near end status when a low signal is detected.	High: high impedance Low: more than -5 mA, 0 V
8	7	Input <sup>2</sup>	<b>Reprint signal (PRIN2)</b> Prints the previously printed content again when a low signal is detected.	High: high impedance Low: more than -5 mA, 0 V
9	-	Input <sup>2</sup>	<b>Backfeed order signal (DISPENSE IN)</b> When [Backfeed] in the [Printing] menu is set to [Controlled], backfeed is performed when a low signal is detected.	High: high impedance Low: more than -5 mA, 0 V
10	-	Input <sup>2</sup>	Reserve	High: high impedance Low: more than -5 mA, 0 V
11	-	-	<b>OUT_COM</b> Ground of peripherals	-

Pin No.		I/O	Description	Electric Conditions (Voltage, Current (Max))
25-pin	14-pin			
12	13	-	Power source	+5 V 600 mA <sup>3</sup>
13	12	-	Power source	+24 V 2 A
14	2	-	<b>GND</b> Reference Signal Ground	-
15	2	-	<b>OUT_COM</b> Ground of peripherals	-
16	3	Output	<b>RFID Tag Error</b> Outputs a low signal when an RFID tag error occurs.	40 V 80 mA
17	1	Output	<b>Paper End/Ribbon End</b> Outputs a low signal when the paper end or the ribbon end is detected.	40 V 80 mA
18	10	Output	<b>Ribbon Near End</b> Outputs a high signal when the ribbon near end is detected.	40 V 80 mA
19	-	Output	Reserve	40 V 80 mA
20	5	Input <sup>2</sup>	<b>Print Start signal (PRIN)</b> Prints one media when a low signal is detected.	High: high impedance Low: more than -5 mA, 0 V
21	11	Input <sup>2</sup>	<b>Feed signal</b> Media feeds when a low signal is detected.	High: high impedance Low: more than -5 mA, 0 V
22	-	Input <sup>2</sup>	Reserve	High: high impedance Low: more than -5 mA, 0 V
23	-	Input <sup>2</sup>	Reserve	High: high impedance Low: more than -5 mA, 0 V

Pin No.		I/O	Description	Electric Conditions (Voltage, Current (Max))
25-pin	14-pin			
24	13	Input	<b>IN_COM</b> <sup>1</sup> Power supply from peripherals	5 V - 24 V or GND
25	-	-	<b>GND</b> Reference Signal Ground	-

<sup>1</sup> When using the 14-pin conversion cable, do not connect the power pin to "IN\_COM" pin. The "IN\_COM" pin is connected to 5 V in cable.

<sup>2</sup> These input signal terminals can be connected to the open collector input devices.

<sup>3</sup> If 25-pin is selected, the total output of Pin No. 2 and 12 will be 600 mA.



- You can set the pin number for input and output through the [Settings] > [Interface] > [External I/O] > [Signals] > [Inputs] and [Outputs] menu.
- 

### Timing Chart of the EXT Input/Output Signal

Refer to the programming references regarding the timing chart for the input signal and the output signal.

For programming references, contact your SATO sales representative or technical support.

## Wireless LAN Interface

This interface complies with the IEEE802.11a/b/g/n/ac standard.



- Before using wireless LAN near medical devices and facilities, consult your system administrator.

Basic Specifications	
Protocol	<ul style="list-style-type: none"> <li>• STATUS3</li> <li>• STATUS4</li> <li>• STATUS5</li> </ul>
IP Address	<ul style="list-style-type: none"> <li>• IPv4</li> <li>• IPv6</li> </ul>
Subnet Mask	<ul style="list-style-type: none"> <li>• IPv4</li> <li>• IPv6</li> </ul>
Gateway Address	<ul style="list-style-type: none"> <li>• IPv4</li> <li>• IPv6</li> </ul>
Data Transfer Method	<p><b>802.11a</b> Max 54 Mbps</p> <p><b>802.11n</b> Max 135 Mbps</p> <p><b>802.11b</b> Max 11 Mbps</p> <p><b>802.11g</b> Max 54 Mbps</p> <p><b>802.11ac</b> Max 390 Mbps</p> <hr/> <p> • These are the theoretical values based on the wireless LAN specifications and are not the actual data transfer speeds.</p> <hr/>
Frequency Band	<ul style="list-style-type: none"> <li>• 2.4 GHz (2.412 to 2.472 GHz)</li> <li>• 5 GHz (5.180 to 5.825 GHz)</li> </ul>
Communication Channel	The number of channels you can set varies depending on the region where you use the product.
SSID	Any alphanumeric character (Maximum 32)



Basic Specifications	
Authentication	<ul style="list-style-type: none"> <li>• Open System</li> <li>• Shared Key</li> <li>• WPA/WPA2</li> <li>• Perform the RADIUS server authentication using 802.1x (EAP-TLS, EAP-LEAP, EAP-TTLS, EAP-PEAP, EAP-FAST protocol)</li> </ul>
Encryption	<ul style="list-style-type: none"> <li>• None</li> <li>• WEP (64 bits/128 bits)</li> <li>• TKIP (WPA-PSK, WPA-802.1x)</li> <li>• AES (WPA2-PSK, WPA2-802.1x)</li> </ul>
Communication Mode	<ul style="list-style-type: none"> <li>• Infrastructure</li> <li>• Ad Hoc</li> </ul>

Software Specifications	
Supported Protocol	TCP/IP
Network Layer	<ul style="list-style-type: none"> <li>• IP</li> <li>• ICMP</li> </ul>
Session Layer	<ul style="list-style-type: none"> <li>• TCP</li> <li>• UDP</li> </ul>
Application Layer	<ul style="list-style-type: none"> <li>• LPR</li> <li>• FTP</li> <li>• HTTP/HTTPS</li> <li>• SNMP</li> <li>• DHCP</li> <li>• NTP</li> </ul>



• Specifications are subject to change without notice.

---

## Printer Languages

---

- SBPL (Includes XML support)
- SZPL
- SDPL
- SIPL

## Standards

---

Item	Description
Environmental Standard	Compatible with the RoHS directive



- Specifications are subject to change without notice.
-

## Usable Media



- Use our specified supply products.

### Type

- Media roll (Face-in wound/face-out wound)



- Some RFID tags may cause paper jams because the tags rise up during backfeed. Please check the performance of each RFID tag that you use. Be careful especially when you use the RFID tags that are less than 27 mm (1.06") long in cold environments.

### Size

- Continuous

Item	S84NX	S86NX
Media Length	<b>203 dpi</b> 6 to 2500 mm (0.24" to 98.43") <b>305 dpi</b> 6 to 1500 mm (0.24" to 59.01") <b>609 dpi</b> 6 to 400 mm (0.24" to 15.75")	<b>203 dpi</b> 6 to 2500 mm (0.24" to 98.43") <b>305 dpi</b> 6 to 1500 mm (0.24" to 59.01")
Media Length (With Liner)	<b>203 dpi</b> 9 to 2503 mm (0.35" to 98.54") <b>305 dpi</b> 9 to 1503 mm (0.35" to 59.17") <b>609 dpi</b> 9 to 403 mm (0.35" to 15.87")	<b>203 dpi</b> 9 to 2503 mm (0.35" to 98.54") <b>305 dpi</b> 9 to 1503 mm (0.35" to 59.17")
Media Width	10 to 128 mm (0.39" to 5.04")	51 to 177 mm (2.01" to 6.97")
Media Width (With Liner)	13 to 131 mm (0.51" to 5.16")	54 to 180 mm (2.13" to 7.08")

\*Above pitch and width are valid for die-cut labels. For media without liner, such as tags or non die-cut labels, use the 'with liner' values.

- Dispenser

Item	S84NX	S86NX
Media Length	<b>Thermal transfer</b> 10 to 356 mm (0.39" to 14.02") <b>Direct thermal</b> 15 to 356 mm (0.60" to 14.02")	
Media Length (With Liner)	<b>Thermal transfer</b> 13 to 359 mm (0.51" to 14.13") <b>Direct thermal</b> 18 to 359 mm (0.71" to 14.13")	
Media Width	10 to 128 mm (0.39" to 5.04")	51 to 177 mm (2.01" to 6.97")
Media Width (With Liner)	13 to 131 mm (0.51" to 5.16")	54 to 180 mm (2.13" to 7.08")

\*Above pitch and width are valid for die-cut labels. For media without liner, such as tags or non die-cut labels, use the 'with liner' values.

- Dispense & Print

Item	S84NX	S86NX
Media Length	The usable media lengths varies depending on the print speed. 2 ips: 34 to 356 mm (1.34" to 14.02") 3 ips: 34 to 356 mm (1.34" to 14.02") 4 ips: 34 to 356 mm (1.34" to 14.02") 5 ips: 34 to 356 mm (1.34" to 14.02") 6 ips: 34 to 356 mm (1.34" to 14.02") 7 ips: 34 to 356 mm (1.34" to 14.02") 8 ips: 34 to 356 mm (1.34" to 14.02") 9 ips: 34 to 356 mm (1.34" to 14.02") 10 ips: 34 to 356 mm (1.34" to 14.02") 11 ips: 34 to 356 mm (1.34" to 14.02") 12 ips: 37 to 356 mm (1.46" to 14.02") 13 ips: 41 to 356 mm (1.61" to 14.02") 14 ips: 46 to 356 mm (1.81" to 14.02") 15 ips: 50 to 356 mm (1.97" to 14.02") 16 ips: 56 to 356 mm (2.20" to 14.02")	
Media Length (With Liner)	The usable media lengths varies depending on the print speed. 2 ips: 37 to 359 mm (1.46" to 14.13")	

Item	S84NX	S86NX
	3 ips: 37 to 359 mm (1.46" to 14.13") 4 ips: 37 to 359 mm (1.46" to 14.13") 5 ips: 37 to 359 mm (1.46" to 14.13") 6 ips: 37 to 359 mm (1.46" to 14.13") 7 ips: 37 to 359 mm (1.46" to 14.13") 8 ips: 37 to 359 mm (1.46" to 14.13") 9 ips: 37 to 359 mm (1.46" to 14.13") 10 ips: 37 to 359 mm (1.46" to 14.13") 11 ips: 37 to 359 mm (1.46" to 14.13") 12 ips: 37 to 359 mm (1.46" to 14.13") 13 ips: 44 to 359 mm (1.73" to 14.13") 14 ips: 49 to 359 mm (1.93" to 14.13") 15 ips: 53 to 359 mm (2.09" to 14.13") 16 ips: 59 to 359 mm (2.32" to 14.13")	
Media Width	10 to 128 mm (0.39" to 5.04")	51 to 177 mm (2.01" to 6.97")
Media Width (With Liner)	13 to 131 mm (0.51" to 5.16")	54 to 180 mm (2.13" to 7.08")

\*Above pitch and width are valid for die-cut labels. For media without liner, such as tags or non die-cut labels, use the 'with liner' values.



- The usable media sizes and print quality depends conditions such as print speed, media, media/ribbon combination, product settings and used environment. It is highly recommended to check the performance based on actual usage conditions in advance.

#### Core Diameter (Media Roll)

- φ76 mm (φ3")

#### Thickness

- 50 to 310 μm (0.050 to 0.310 mm (0.0020" to 0.012"))



- The thickness of the thickest part of the RFID tag is more than 310 μm (0.31 mm (0.012")). Be sure to do tests beforehand.

## Media Size for Each Print Speed

The minimum media length varies by the print speed setting.

Print speed (inches/ sec)	Continuous mode	Dispenser mode		Dispense & Print mode
	Minimum media length (with liner) (mm)	(Thermal transfer) Minimum media length (with liner) (mm)	(Direct thermal) Minimum media length (with liner) (mm)	Minimum media length (with liner) (mm)
2	9	13	18	37
3	9	13	18	37
4	9	13	18	37
5	11	13	18	37
6	13	13	18	37
7	15	13	18	37
8	17	13	18	37
9	20	13	18	37
10	23	13	18	37
11	27	13	18	37
12	31	16	18	40
13	35	20	20	44
14	40	25	25	49
15	44	29	29	53
16	50	35	35	59





- If using media smaller than the minimum size, the media will not stop at the right position, causing a print misalignment.
- Do not send the print data with media size that is smaller than the minimum media length, even when the sensor is disabled.
- The above minimum media length are valid only if the print position adjustment and offset adjustment are set to 0 mm. The minimum media length changes when the print position adjustment and offset adjustment are set to the value other than 0 mm.

## Usable Ribbon



- Use our specified supply products.

Item	S84NX	S86NX
Size	<p><b>Length</b> Maximum 600 m (1968.5 feet)</p> <p><b>Width</b> 25 to 128 mm (0.98" to 5.04")</p> <hr/> <p> <ul style="list-style-type: none"> <li>• When the width of the ribbon is 39.5 mm (1.55"), the maximum length is 450 m (1476.4 feet).</li> <li>• The maximum length of the ribbon varies depending on the ribbon type.</li> <li>• Use the ribbon that is wider than the media.</li> </ul> </p> <hr/>	<p><b>Length</b> Maximum 600 m (1968.5 feet)</p> <p><b>Width</b> 59 to 177 mm (2.32" to 6.97")</p> <hr/> <p> <ul style="list-style-type: none"> <li>• The maximum length of the ribbon varies depending on the ribbon type.</li> <li>• Use the ribbon that is wider than the media.</li> </ul> </p> <hr/>
Winding Direction	Both face-out/face-in	
Winding Method	Winding on core	



# Usable Fonts

## Bitmap Fonts

Item	S84NX	S86NX
<a href="#">U</a>	9 dots H x 5 dots W	
<a href="#">S</a>	15 dots H x 8 dots W	
<a href="#">M</a>	20 dots H x 13 dots W	
<a href="#">WB</a>	30 dots H x 18 dots W	
<a href="#">WL</a>	52 dots H x 28 dots W	
<a href="#">XU</a>	9 dots H x 5 dots W	
<a href="#">XS</a>	17 dots H x 17 dots W	
<a href="#">XM</a>	24 dots H x 24 dots W	
<a href="#">XB</a>	48 dots H x 48 dots W	
<a href="#">XL</a>	48 dots H x 48 dots W	
<a href="#">X20</a>	9 dots H x 5 dots W	
<a href="#">X21</a>	17 dots H x 17 dots W	
<a href="#">X22</a>	24 dots H x 24 dots W	
<a href="#">X23</a>	48 dots H x 48 dots W	
<a href="#">X24</a>	48 dots H x 48 dots W	
<a href="#">OCR-A</a>	<b>203 dpi</b> 22 dots H x 15 dots W <b>305 dpi</b> 33 dots H x 22 dots W <b>609 dpi</b> 66 dots H x 44 dots W	<b>203 dpi</b> 22 dots H x 15 dots W <b>305 dpi</b> 33 dots H x 22 dots W
<a href="#">OCR-B</a>	<b>203 dpi</b> 24 dots H x 20 dots W <b>305 dpi</b> 36 dots H x 30 dots W <b>609 dpi</b> 72 dots H x 60 dots W	<b>203 dpi</b> 24 dots H x 20 dots W <b>305 dpi</b> 36 dots H x 30 dots W

Item	S84NX	S86NX
JIS208 Kanji Fonts (Mincho/Gothic)	<ul style="list-style-type: none"> <li>• 16 dots H x 16 dots W</li> <li>• 24 dots H x 24 dots W</li> <li>• 22 dots H x 22 dots W</li> <li>• 32 dots H x 32 dots W</li> <li>• 40 dots H x 40 dots W</li> </ul>	
JIS0213 Kanji Fonts (Gothic)	<ul style="list-style-type: none"> <li>• 16 dots H x 16 dots W</li> <li>• 24 dots H x 24 dots W</li> <li>• 22 dots H x 22 dots W</li> <li>• 32 dots H x 32 dots W</li> <li>• 40 dots H x 40 dots W</li> </ul>	
Compatible Kanji Fonts (Mincho)	<ul style="list-style-type: none"> <li>• 16 dots H x 16 dots W</li> <li>• 24 dots H x 24 dots W</li> </ul>	
Simplified Chinese Characters	<ul style="list-style-type: none"> <li>• 16 dots H x 16 dots W</li> <li>• 24 dots H x 24 dots W</li> </ul>	
Traditional Chinese Characters	<ul style="list-style-type: none"> <li>• 24 dots H x 24 dots W</li> </ul>	
Korean Fonts	<ul style="list-style-type: none"> <li>• 16 dots H x 16 dots W</li> <li>• 24 dots H x 24 dots W</li> </ul>	

### Scalable Fonts

Item	S84NX	S86NX
<a href="#">Rasterized Font</a>	<ul style="list-style-type: none"> <li>• SATO CG Sleek</li> <li>• SATO CG Stream</li> <li>• SATO 0</li> <li>• SATO Alpha Bold Condensed</li> <li>• SATO Beta Bold Italic</li> <li>• SATO Folio Bold</li> <li>• SATO Futura Medium Condensed</li> <li>• SATO Gamma</li> <li>• SATO OCR-A</li> <li>• SATO OCR-B</li> <li>• SATO Sans</li> <li>• SATO Serif</li> <li>• SATO Symbol Set</li> </ul>	

Item	S84NX	S86NX
	<ul style="list-style-type: none"> <li>• SATO Vica</li> <li>• SATO WingBats</li> </ul>	
<a href="#">Rasterized Font (Multilingual)</a>	<ul style="list-style-type: none"> <li>• SATO Hebe Sans</li> <li>• SATO Hebe Sans Arabic</li> <li>• SATO Hebe Sans Thai</li> <li>• SATO Hebe Sans Hebrew</li> <li>• SATO Hebe Sans Hindi</li> <li>• SATO Gothic Traditional Chinese</li> <li>• SATO Gothic Japanese</li> <li>• SATO Gothic Simplified Chinese</li> <li>• SATO Gothic Korean</li> <li>• SATO Silver Serif</li> <li>• SATO Mincho Traditional Chinese</li> <li>• SATO Mincho Japanese</li> <li>• SATO Mincho Simplified Chinese</li> <li>• SATO Mincho Korean</li> <li>• SATO Roman Arabic</li> </ul>	
<a href="#">Outline Fonts</a>	<ul style="list-style-type: none"> <li>• Helvetica Outline Font</li> <li>• JIS208 Kanji Outline Fonts</li> </ul>	



• Specifications are subject to change without notice.

---

## X20 Font

The X20 font is a bitmap font with a basic size of 9 dots H x 5 dots W.

This supports the fixed pitch only.

A font sample is shown in the figure below.

	2	3	4	5	6	7	8	9	A	B	C	D	E	F
<b>0</b>		ø	ø	P		p				-	ヲ	ミ		
<b>1</b>	!	1	A	Q	a	q				ア	チ	ム		
<b>2</b>	"	2	B	R	b	r				イ	ツ	メ		
<b>3</b>	#	3	C	S	c	s				ウ	テ	モ		
<b>4</b>	\$	4	D	T	d	t				エ	ト	セ		
<b>5</b>	%	5	E	U	e	u			・	オ	ヲ	ユ		
<b>6</b>	&	6	F	V	f	v			ヨ	カ	ニ	ヨ		
<b>7</b>	'	7	G	W	g	w				キ	ヌ	ラ		
<b>8</b>	<	8	H	X	h	x				ク	ネ	リ		
<b>9</b>	>	9	I	Y	i	y				ケ	ノ	ル		
<b>A</b>	*	:	J	Z	j	z				コ	ハ	レ		
<b>B</b>	+	;	K	¢	k	-				サ	ヒ	ロ		
<b>C</b>	,	<	L	¥	l	-				シ	フ	ワ		
<b>D</b>	-	=	M		m					ス	ヘ	ン		
<b>E</b>	.	>	N		n	!				セ	ホ	〃		
<b>F</b>	/	?	O		o					ソ	マ	◇		

## X21 Font

The X21 font is a bitmap font with a basic size of 17 dots H x 17 dots W.

You can select fixed pitch or proportional pitch.

A font sample is shown in the figure below.

	2	3	4	5	6	7	8	9	A	B	C	D	E	F
0	ø	@	P	'	p				一	タ	ミ			
1	!	1	A	Q	a	q			。	ア	チ	ム		
2	"	2	B	R	b	r			「	イ	ツ	メ		
3	#	3	C	S	c	s			」	ウ	テ	モ		
4	\$	4	D	T	d	t			、	エ	ト	ヤ		
5	%	5	E	U	e	u			・	オ	ナ	ユ		
6	&	6	F	V	f	v			ヲ	カ	ニ	ヨ		
7	'	7	G	W	g	w			ア	キ	ヌ	ラ		
8	(	8	H	X	h	x			イ	ク	ネ	リ		
9	)	9	I	Y	i	y			ウ	ケ	ノ	ル		
A	*	:	J	Z	j	z			エ	コ	ハ	レ		
B	+	;	K	[	k	{			オ	サ	ヒ	ロ		
C	,	<	L	¥	l	;			ヤ	シ	フ	ワ		
D	-	=	M	]	m	}			ユ	ス	ヘ	ソ		
E	.	>	N	^	n	~			ヨ	セ	ホ	°		
F	/	?	0	_	o				ツ	ソ	マ	°		



- To select proportional pitch, enable [SBPL] > [Font Settings] > [Proportional] in the [Applications] menu, or specify with the command.

## X22 Font

The X22 font is a bitmap font with a basic size of 24 dots H x 24 dots W.

You can select fixed pitch or proportional pitch.

A font sample is shown in the figure below.

	2	3	4	5	6	7	8	9	A	B	C	D	E	F
0	0	@	P	`	p				一	タ	ミ			
1	!	1	A	Q	a	q			。	ア	チ	ム		
2	”	2	B	R	b	r			「	イ	ツ	メ		
3	#	3	C	S	c	s			」	ウ	テ	モ		
4	\$	4	D	T	d	t			、	エ	ト	ヤ		
5	%	5	E	U	e	u			-	オ	ナ	ユ		
6	&	6	F	V	f	v			ヲ	カ	ニ	ヨ		
7	'	7	G	W	g	w			ア	キ	ヌ	ラ		
8	(	8	H	X	h	x			イ	ク	ネ	リ		
9	)	9	I	Y	i	y			ウ	ケ	ノ	ル		
A	*	:	J	Z	j	z			エ	コ	ハ	レ		
B	+	;	K	[	k	{			オ	サ	ヒ	ロ		
C	,	<	L	¥	!	!			ヤ	シ	フ	ワ		
D	-	=	M	]	m	}			ユ	ス	ヘ	ン		
E	.	>	N	^	n	~			ヨ	セ	ホ	°		
F	/	?	O	_	o				ツ	ソ	マ	°		



- To select proportional pitch, enable [SBPL] > [Font Settings] > [Proportional] in the [Applications] menu, or specify with the command.

## X23 Font

The X23 font is a bitmap font with a basic size of 48 dots H x 48 dots W.

You can select fixed pitch or proportional pitch.

A font sample is shown in the figure below.

	2	3	4	5	6	7	8	9	A	B	C	D	E	F
0	0	@	P	`	p				一	タ	ミ			
1	!	1	A	Q	a	q			。	ア	チ	ム		
2	"	2	B	R	b	r			「	イ	ツ	メ		
3	#	3	C	S	c	s			」	ウ	テ	モ		
4	\$	4	D	T	d	t			、	エ	ト	ヤ		
5	%	5	E	U	e	u			・	オ	ナ	ユ		
6	&	6	F	V	f	v			ヲ	カ	ニ	ヨ		
7	'	7	G	W	g	w			ア	キ	ヌ	ラ		
8	(	8	H	X	h	x			イ	ク	ネ	リ		
9	)	9	I	Y	i	y			ウ	ケ	ノ	ル		
A	*	:	J	Z	j	z			エ	コ	ハ	レ		
B	+	;	K	[	k	{			オ	サ	ヒ	ロ		
C	,	<	L	¥	!	!			ヤ	シ	フ	ワ		
D	-	=	M	]	m	}			ユ	ス	ヘ	ン		
E	.	>	N	^	n	~			ヨ	セ	ホ	°		
F	/	?	O	_	o				ツ	ソ	マ	°		



- To select proportional pitch, enable [SBPL] > [Font Settings] > [Proportional] in the [Applications] menu, or specify with the command.

## X24 Font

The X24 font is a bitmap font with a basic size of 48 dots H x 48 dots W.

You can select fixed pitch or proportional pitch.

A font sample is shown in the figure below.

	2	3	4	5	6	7	8	9	A	B	C	D	E	F
<b>0</b>	0	@	P	'	p				一	タ	ミ			
<b>1</b>	!	1	A	Q	a	q			。	ア	チ	ム		
<b>2</b>	"	2	B	R	b	r			「	イ	ツ	メ		
<b>3</b>	#	3	C	S	c	s			」	ウ	テ	モ		
<b>4</b>	\$	4	D	T	d	t			、	エ	ト	ヤ		
<b>5</b>	%	5	E	U	e	u			・	オ	ナ	ユ		
<b>6</b>	&	6	F	V	f	v			ヲ	カ	ニ	ヨ		
<b>7</b>	'	7	G	W	g	w			ア	キ	ヌ	ラ		
<b>8</b>	(	8	H	X	h	x			イ	ク	ネ	リ		
<b>9</b>	)	9	I	Y	i	y			ウ	ケ	ノ	ル		
<b>A</b>	*	:	J	Z	j	z			エ	コ	ハ	レ		
<b>B</b>	+	;	K	[	k	{			オ	サ	ヒ	ロ		
<b>C</b>	,	<	L	¥	l	!			ヤ	シ	フ	フ		
<b>D</b>	-	=	M	]	m	}			ユ	ス	ヘ	ン		
<b>E</b>	.	>	N	^	n	~			ヨ	セ	ホ	°		
<b>F</b>	/	?	O	_	o				ツ	ソ	マ	°		



- To select proportional pitch, enable [SBPL] > [Font Settings] > [Proportional] in the [Applications] menu, or specify with the command.



## U Font

The U font is a bitmap font with a basic size of 9 dots H x 5 dots W.

This supports the fixed pitch only.

The figure below is a font sample when the code page 858 is used.

	2	3	4	5	6	7	8	9	A	B	C	D	E	F
<b>0</b>	ø	ø	ø	ø	ø	ø	ø	ø	ø	ø	ø	ø	ø	-
<b>1</b>	!	1	À	Q	a	q	ü	æ	í			Ð	β	±
<b>2</b>	"	2	B	R	b	r	é	Æ	ó			é	ó	=
<b>3</b>	#	3	C	S	c	s	á	ô	ú			ë	ò	¼
<b>4</b>	\$	4	D	T	d	t	ä	ö	ñ			è	ø	¶
<b>5</b>	%	5	E	U	e	u	à	ò	ñ	á		€	ø	§
<b>6</b>	&	6	F	V	f	v	á	û	æ	á	ã	í	µ	÷
<b>7</b>	'	7	G	W	g	w	ç	ù	ø	à	ã	î	þ	,
<b>8</b>	<	8	H	X	h	x	é	ÿ	ú	ø		ï	þ	°
<b>9</b>	>	9	I	Y	i	y	ë	ö	»			ó	´	¨
<b>A</b>	*	:	J	Z	j	z	è	ü	˘			ó	+	
<b>B</b>	+	;	K	[	k	{	ï	ø	¼			ù	l	
<b>C</b>	,	<	L	\	l		î	£	¼			ý	³	
<b>D</b>	-	=	M	]	m	}	ì	§	ì	ø		ì	ý	²
<b>E</b>	.	>	N	^	n	˘	ñ	x	«	¥		ì	˘	
<b>F</b>	/	?	O	_	o	¸	á	f	»		¸		'	



- The character set is changed according to the [SBPL] > [Font Settings] > [Code Page] settings in the [Applications] menu or the code page specified using commands.

## S Font

The S font is a bitmap font with a basic size of 15 dots H x 8 dots W.

This supports the fixed pitch only.

The figure below is a font sample when the code page 858 is used.

	2	3	4	5	6	7	8	9	A	B	C	D	E	F
0	ø	ø	ø	P	'	p	ç	é	á	ø		ø	ó	-
1	!	1	A	Q	a	q	ü	æ	í			Ð	β	±
2	"	2	B	R	b	r	é	Æ	ó			Ê	ô	=
3	#	3	C	S	c	s	â	ô	ú			Ë	ò	¾
4	\$	4	D	T	d	t	ä	ö	ñ			È	õ	¶
5	%	5	E	U	e	u	à	ò	Ñ	Á		€	õ	§
6	&	6	F	V	f	v	à	û	â	Â	ã	í	μ	÷
7	'	7	G	W	g	w	ç	ù	º	À	Ã	î	þ	,
8	(	8	H	X	h	x	ê	ÿ	¿	©		ï	þ	°
9	)	9	I	Y	i	y	ë	ö	®			ú	¨	
A	*	:	J	Z	j	z	è	ü	™			û	•	
B	+	;	K	[	k	{	ï	ø	½			ù	¡	
C	,	<	L	\	l	!	î	£	¼			ý	³	
D	-	=	M	]	m	}	ì	ø	¡	¢		ì	ý	²
E	.	>	N	^	n	~	Ä	X	«	¥		ì	´	
F	/	?	O	_	o	■	Á	f	»		◊		´	



- The character set is changed according to the [SBPL] > [Font Settings] > [Code Page] settings in the [Applications] menu or the code page specified using commands.

## M Font

The M font is a bitmap font with a basic size of 20 dots H x 13 dots W.

This supports the fixed pitch only.

The figure below is a font sample when the code page 858 is used.

	2	3	4	5	6	7	8	9	A	B	C	D	E	F
0	ø	@	P	'	p	ç	é	á	ø		ö	ó	-	
1	!	1	A	Q	a	q	ü	æ	í			Ð	β	±
2	”	2	B	R	b	r	é	Æ	ó			Ê	Ô	=
3	#	3	C	S	c	s	â	ô	ú			Ë	Ò	¼
4	\$	4	D	T	d	t	ä	ö	ñ			È	Õ	¶
5	%	5	E	U	e	u	à	ò	Ñ	Á		€	Ö	§
6	&	6	F	V	f	v	å	û	æ	Â	ã	í	μ	÷
7	'	7	G	W	g	w	ç	ù	ø	À	Ã	î	þ	,
8	(	8	H	X	h	x	ê	ÿ	ı	©		Ï	Þ	°
9	)	9	I	Y	i	y	ë	ö	®				Ú	¨
A	*	:	J	Z	j	z	è	ü	¬				Û	•
B	+	;	K	[	k	{	ï	ø	½				Ü	¡
C	,	<	L	\	l	!	î	£	¼				Ý	³
D	-	=	M	]	m	}	ì	Ø	ı	¢		ı	Ý	²
E	.	>	N	^	n	~	Ä	X	«	¥		ì	-	
F	/	?	O	_	o	■	Å	f	»		⊗		'	



- The character set is changed according to the [SBPL] > [Font Settings] > [Code Page] settings in the [Applications] menu or the code page specified using commands.

## WB Font

The WB font is a bitmap font with a basic size of 30 dots H x 18 dots W.

This supports the fixed pitch only.

The figure below is a font sample when the code page 858 is used.

	2	3	4	5	6	7	8	9	A	B	C	D	E	F
<b>0</b>	ø	@	P	'	p	Ç	É	á	ø			ð	ó	-
<b>1</b>	!	1	A	Q	a	q	ü	æ	í			Ð	β	±
<b>2</b>	"	2	B	R	b	r	é	Æ	ó			Ê	ô	=
<b>3</b>	#	3	C	S	c	s	â	ô	ú			Ë	ò	¼
<b>4</b>	\$	4	D	T	d	t	ä	ö	ñ			È	õ	¶
<b>5</b>	%	5	E	U	e	u	à	ò	Ñ	Á		€	ö	§
<b>6</b>	&	6	F	V	f	v	â	û	ä	Â	ã	í	μ	÷
<b>7</b>	'	7	G	W	g	w	ç	ù	ó	À	Ã	î	þ	,
<b>8</b>	(	8	H	X	h	x	ê	ÿ	¿	©		ï	þ	°
<b>9</b>	)	9	I	Y	i	y	ë	ö	®			ú	ˆ	ˆ
<b>A</b>	*	:	J	Z	j	z	è	ü	¬			ó	•	•
<b>B</b>	+	;	K	[	k	{	ï	ø	½			ù	ı	ı
<b>C</b>	,	<	L	\	l		î	£	¼			ý	³	³
<b>D</b>	-	=	M	]	m	}	ì	Ø	ı	∅		ı	ý	²
<b>E</b>	.	>	N	^	n	~	Ä	x	«	¥		ì	-	-
<b>F</b>	/	?	O	_	o	■	Á	f	»		α		'	'



- The character set is changed according to the [SBPL] > [Font Settings] > [Code Page] settings in the [Applications] menu or the code page specified using commands.

## WL Font

The WL font is a bitmap font with a basic size of 52 dots H x 28 dots W.

This supports the fixed pitch only.

The figure below is a font sample when the code page 858 is used.

	2	3	4	5	6	7	8	9	A	B	C	D	E	F
0	0	@	P	'	p	Ç	É	á	Ø		ø	ó	-	
1	!	1	A	Q	a	q	ü	æ	í			Ð	β	±
2	"	2	B	R	b	r	é	Æ	ó			Ê	Ô	≡
3	#	3	C	S	c	s	â	ô	ú			È	Ò	¾
4	\$	4	D	T	d	t	ä	ö	ñ			È	õ	π
5	%	5	E	U	e	u	à	ò	Ñ	Á		€	Õ	§
6	&	6	F	V	f	v	å	û	à	Â	ã	Í	μ	÷
7	'	7	G	W	g	w	ç	ù	º	À	Ã	Î	þ	,
8	(	8	H	X	h	x	ê	ÿ	¿	©		ï	þ	°
9	)	9	I	Y	i	y	ë	ö	®				Ú	¨
A	*	:	J	Z	j	z	è	Ü	ˆ				Û	•
B	+	;	K	[	k	{	ï	ø	½				Ü	¹
C	,	<	L	\	l		î	£	¼				Ý	³
D	-	=	M	]	m	}	ì	Ø	¡	¢		!	Ý	²
E	.	>	N	^	n	~	Ä	x	«	¥		ì	˘	
F	/	?	O	_	o	■	Å	f	»		α		˘	



- The character set is changed according to the [SBPL] > [Font Settings] > [Code Page] settings in the [Applications] menu or the code page specified using commands.

## XU Font

The XU font is a bitmap font with a basic size of 9 dots H x 5 dots W.

You can select fixed pitch or proportional pitch.

The figure below is a font sample when the code page 858 is used.

	2	3	4	5	6	7	8	9	A	B	C	D	E	F
<b>0</b>		ø	ø	P	`	p	ç	é	á	ø		ø	ó	-
<b>1</b>	!	1	À	Q	a	q	ü	æ	í			Ð	β	±
<b>2</b>	"	2	B	R	b	r	é	Æ	ó			é	ó	=
<b>3</b>	#	3	C	S	c	s	á	ó	ú			ë	ò	¼
<b>4</b>	\$	4	D	T	d	t	ä	ö	ñ			è	ø	¶
<b>5</b>	%	5	E	U	e	u	à	ò	ñ	á		€	ø	§
<b>6</b>	&	6	F	V	f	v	á	ú	æ	á	ä	í	µ	÷
<b>7</b>	'	7	G	W	g	w	ç	ù	ó	à	ã	î	þ	,
<b>8</b>	<	8	H	X	h	x	é	ý	ú	ø		ï	þ	°
<b>9</b>	>	9	I	Y	i	y	ë	ö	«				ó	~
<b>A</b>	*	:	J	Z	j	z	è	ü	¬				ó	+
<b>B</b>	+	;	K	I	k	{	ï	ø	¼				ù	!
<b>C</b>	,	<	L	\	l		î	£	¼				ý	»
<b>D</b>	-	=	M	I	m	}	ì	§	ì	¢		ì	ý	²
<b>E</b>	.	>	N	^	n	~	ñ	x	«	¥		ì	~	
<b>F</b>	/	?	O	_	o		á	f	»				'	



- To select proportional pitch, enable [SBPL] > [Font Settings] > [Proportional] in the [Applications] menu, or specify with the command.
- The character set is changed according to the [SBPL] > [Font Settings] > [Code Page] settings in the [Applications] menu or the code page specified using commands.

## XS Font

The XS font is a bitmap font with a basic size of 17 dots H x 17 dots W.

You can select fixed pitch or proportional pitch.

The figure below is a font sample when the code page 858 is used.

	2	3	4	5	6	7	8	9	A	B	C	D	E	F
0	ø	@	P	'	p	ç	É	á	ø		ð	ó	-	
1	!	1	A	Q	a	q	ü	æ	í			Ð	ß	±
2	"	2	B	R	b	r	é	Æ	ó			È	Ò	=
3	#	3	C	S	c	s	â	ô	ú			É	Ó	¾
4	\$	4	D	T	d	t	ä	ö	ñ			È	õ	¶
5	%	5	E	U	e	u	à	ò	Ñ	À		€	Ö	§
6	&	6	F	V	f	v	â	û	ä	Â	ã	í	µ	÷
7	'	7	G	W	g	w	ç	ù	ó	À	Á	í	þ	,
8	(	8	H	X	h	x	ê	ÿ	¿	©		ÿ	þ	°
9	)	9	I	Y	i	y	ë	ö	®				Ü	¨
A	*	:	J	Z	j	z	è	Ü	¬				Ö	•
B	+	;	K	[	k	{	ï	ø	½				Ü	¹
C	,	<	L	\	l	!	î	£	¼				ý	³
D	-	=	M	]	m	}	ì	ø	ì	ø		!	ÿ	²
E	.	>	N	^	n	~	Ä	x	«	¥		l	´	
F	/	?	O	_	o	■	Å	f	»		α		´	



- To select proportional pitch, enable [SBPL] > [Font Settings] > [Proportional] in the [Applications] menu, or specify with the command.
- The character set is changed according to the [SBPL] > [Font Settings] > [Code Page] settings in the [Applications] menu or the code page specified using commands.

## XM Font

The XM font is a bitmap font with a basic size of 24 dots H x 24 dots W.

You can select fixed pitch or proportional pitch.

The figure below is a font sample when the code page 858 is used.

	2	3	4	5	6	7	8	9	A	B	C	D	E	F
0	0	@	P	`	p	Ç	É	á	Ø		ð	Ó	-	
1	!	1	A	Q	a	q	ü	æ	í			Ð	β	±
2	”	2	B	R	b	r	é	Æ	ó			Ê	Ô	=
3	#	3	C	S	c	s	â	ô	ú			Ë	Ò	¾
4	\$	4	D	T	d	t	ä	ö	ñ			È	õ	¶
5	%	5	E	U	e	u	à	ò	Ñ	Á		€	Õ	§
6	&	6	F	V	f	v	ã	û	ä	Â	ã	Í	μ	÷
7	'	7	G	W	g	w	ç	ù	º	À	Ã	î	þ	,
8	(	8	H	X	h	x	ê	ÿ	¿	©		ï	þ	°
9	)	9	I	Y	i	y	ë	Ö	®			Ú	”	
A	*	:	J	Z	j	z	è	Ü	¬			Û	•	
B	+	;	K	[	k	{	ï	ø	½			Ü	¹	
C	,	<	L	\	l	;	î	£	¼			Ý	³	
D	-	=	M	]	m	}	ì	Ø	ï	¢		ÿ	²	
E	.	>	N	^	n	~	Ä	x	<<	¥		ÿ	´	
F	/	?	O	_	o	■	Å	f	>>		α	´		



- To select proportional pitch, enable [SBPL] > [Font Settings] > [Proportional] in the [Applications] menu, or specify with the command.
- The character set is changed according to the [SBPL] > [Font Settings] > [Code Page] settings in the [Applications] menu or the code page specified using commands.



## XB Font

The XB font is a bitmap font with a basic size of 48 dots H x 48 dots W.

You can select fixed pitch or proportional pitch.

The figure below is a font sample when the code page 858 is used.

	2	3	4	5	6	7	8	9	A	B	C	D	E	F
0	0	@	P	`	p	Ç	É	á	Ø			Š	Ó	-
1	!	1	A	Q	a	q	ü	æ	í			Ð	β	±
2	"	2	B	R	b	r	é	Æ	ó			Ê	Ô	=
3	#	3	C	S	c	s	â	ô	ú			Ë	Ò	¾
4	\$	4	D	T	d	t	ä	ö	ñ			È	õ	¶
5	%	5	E	U	e	u	à	ò	Ñ	Á		€	Õ	§
6	&	6	F	V	f	v	â	û	ä	Ã	ã	Í	μ	÷
7	'	7	G	W	g	w	ç	ù	ð	À	Ä	î	þ	,
8	(	8	H	X	h	x	ê	ÿ	¿	©		ï	þ	°
9	)	9	I	Y	i	y	ë	Ö	®			Ú	..	
A	*	:	J	Z	j	z	è	Ü	¬			Û	•	
B	+	;	K	[	k	{	ï	ø	½			Ü	¹	
C	,	<	L	\	l	!	î	£	¼			Ý	³	
D	-	=	M	]	m	}	ï	ø	¡	¢		!;	Ý	²
E	.	>	N	^	n	~	Ä	×	«	¥		ì	-	
F	/	?	O	_	o	■	Å	f	»		α	´		



- To select proportional pitch, enable [SBPL] > [Font Settings] > [Proportional] in the [Applications] menu, or specify with the command.
- The character set is changed according to the [SBPL] > [Font Settings] > [Code Page] settings in the [Applications] menu or the code page specified using commands.

## XL Font

The XL font is a bitmap font with a basic size of 48 dots H x 48 dots W.

You can select fixed pitch or proportional pitch.

The figure below is a font sample when the code page 858 is used.

	2	3	4	5	6	7	8	9	A	B	C	D	E	F
0	0	@	P	'	p	Ç	É	á	Ø			ð	Ó	-
1	!	1	A	Q	a	q	ü	æ	í			Ð	β	±
2	"	2	B	R	b	r	é	Æ	ó			Ê	Ô	=
3	#	3	C	S	c	s	â	ô	ú			Ë	Ò	¾
4	\$	4	D	T	d	t	ä	ö	ñ			È	õ	¶
5	%	5	E	U	e	u	à	ò	Ñ	Á		€	Õ	§
6	&	6	F	V	f	v	â	û	ª	Â	ã	Í	μ	÷
7	'	7	G	W	g	w	ç	ù	º	À	Ã	Î	þ	,
8	(	8	H	X	h	x	ê	ÿ	¿	©		Ï	ƒ	°
9	)	9	I	Y	i	y	ë	Ö	®			¼	Ú	••
A	*	:	J	Z	j	z	è	Ü	¬			½	Û	•
B	+	;	K	[	k	{	ï	ø	½			¾	Ü	¹
C	,	<	L	\	l		î	£	¼			¾	Ý	³
D	-	=	M	]	m	}	ì	Ø	ì	¢		¾	Ý	²
E	.	>	N	^	n	~	Ä	x	«	¥		¾	Ý	
F	/	?	O	_	o	■	Å	f	»		α	¾	Ý	



- To select proportional pitch, enable [SBPL] > [Font Settings] > [Proportional] in the [Applications] menu, or specify with the command.
- The character set is changed according to the [SBPL] > [Font Settings] > [Code Page] settings in the [Applications] menu or the code page specified using commands.

## OCR-A Font

The OCR-A font is a bitmap font. The basic size varies depending on the print resolutions as follows:

This supports the fixed pitch only.

The figure below is a font sample when the print resolution is 203 dpi (8 dots/mm).

	2	3	4	5	6	7	8	9	A	B	C	D	E	F
0		0		P										
1		1	A	Q										
2		2	B	R										
3		3	C	S										
4	4	4	D	T										
5		5	E	U										
6		6	F	V										
7		7	G	W										
8		8	H	X										
9		9	I	Y										
A			J	Z										
B			K											
C			L											
D			M											
E	.	>	N											
F	/		o											

## OCR-B Font

The OCR-B font is a bitmap font. The basic size varies depending on the print resolutions as follows:

This supports the fixed pitch only.

The figure below is a font sample when the print resolution is 203 dpi (8 dots/mm).

	2	3	4	5	6	7	8	9	A	B	C	D	E	F
0		0	@	P										
1	!	1	A	Q										
2	"	2	B	R										
3	#	3	C	S										
4	\$	4	D	T										
5	%	5	E	U										
6	&	6	F	V										
7	'	7	G	W										
8	(	8	H	X										
9	)	9	I	Y										
A	*	:	J	Z										
B	+	;	K	¥										
C	,	<	L	¥										
D	-	=	M											
E	.	>	N											
F	/	?	O											

## Outline Fonts

The font type, font size and font shape can be specified for the outline fonts.

For the font type, you can select fixed pitch or proportional pitch. You can also specify kanji, but kanji supports fixed pitch only.

The figure below is a sample of some font shapes. Shapes such as normal font, white characters on black background, grey font, font with shadow, mirrored font and italic font can be specified.

**This is a sample of Outline font.**

**Outline font0 ABCabc123**  
**Outline font1 ABCabc123**  
**Outline font2 ABCabc123**  
**Outline font3 ABCabc123**  
**Outline font4 ABCabc123**  
**Outline font5 ABCabc123**  
**Outline font6 ABCabc123**  
**Outline font7 ABCabc123**  
**Outline font8 ABCabc123**  
**Outline font9 ABCabc123**

The figure below is a font sample with the standard font.

	2	3	4	5	6	7	8	9	A	B	C	D	E	F
0		0	@	P	'	p	Ç	É	á			ð	Ó	–
1	!	1	A	Q	a	q	ü	æ	í			Ð	β	±
2	"	2	B	R	b	r	é	Æ	ó			Ê	Ô	=
3	#	3	C	S	c	s	â	ô	ú			Ë	Ò	¾
4	\$	4	D	T	d	t	ä	ö	ñ			È	õ	
5	%	5	E	U	e	u	à	ò	Ñ	Á		€	Õ	
6	&	6	F	V	f	v	å	û	a	Â	ã	Í	μ	÷
7	'	7	G	W	g	w	ç	ù	ø	À	Ã	Î	þ	.
8	(	8	H	X	h	x	ê	ÿ	ı	©		İ	Þ	°
9	)	9	I	Y	i	y	ë	Ö	®			Ú	”	
A	*	:	J	Z	j	z	è	Ü	¬			Û	•	
B	+	;	K	[	k	{	ï	ø	½			Ü	'	
C	,	<	L	\	l		î	£	¼			Ý	³	
D	-	=	M	]	m	}	ì	Ø	ı	¢		Ý	²	
E	.	>	N	^	n	~	Ä	×	«	¥		İ	–	
F	/	?	O	_	o		Å	f	»				'	



- The font size can be specified from 1 to 999 dots, but if the font size is too small for the font shape, it cannot be recognized as a font. Please be careful. Also, if the specified font size is too small, it may collapse, depending on the font.

## Multilingual Font

The product contains various multilingual fonts.

The figure below is a sample of some of the multilingual fonts.

<b>b</b>	<b>Fontname</b>	<b>Sample</b>
0	SATO Hebe Sans	This is a fontsample.
8	SATO Silver Serif	This is a fontsample.
1	SATO Hebe Sans Arabic	هذا هو عينة من الخط.
13	SATO Roman Arabic	هذا هو عينة من الخط.
2	SATO Hebe Sans Thai	นี่คือตัวอย่างของตัวอักษร
3	SATO Hebe Sans Hindi	इस फॉन्ट का एक नमूना है.
14	SATO Hebe Sans Hebrew	דוגמה של מונוט פונט
4	SATO Gothic Tradional Chinese	這是字體的樣本。
9	SATO Mincho Tradional Chinese	這是字體的樣本。
6	SATO Gothic Simplified Chinese	这是字体的样本。
11	SATO Mincho Simplified Chinese	这是字体的样本。
5	SATO Gothic Japanese	これはフォントのサンプルです。
10	SATO Mincho Japanese	これはフォントのサンプルです。
7	SATO Gothic Korean	이것은 글꼴의 샘플입니다.
12	SATO Mincho Korean	이것은 글꼴의 샘플입니다.

## Scalable Fonts

The product contains various scalable fonts.

The figure below is a sample of some scalable fonts.

Fontname	Sample
SATOCGSleek.ttf	ABCXYZabcdefghijklmnopqrstuvwxyz123
SATOCGStream.ttf	ABCXYZabcdefghijklmnopqrstuvwxyz123
SAT00CRA.ttf	A B C X Y Z a b c x y z 1 2 3
SAT00.ttf	ABCXYZabcdefghijklmnopqrstuvwxyz123
SAT0ALPHABC.ttf	ABCXYZabcdefghijklmnopqrstuvwxyz123
SAT0BETABI.ttf	<i>ABCXYZabcdefghijklmnopqrstuvwxyz123</i>
SAT0FOLI0B.ttf	<b>ABCXYZabcdefghijklmnopqrstuvwxyz123</b>
SAT0FUTURAMC.ttf	ABCXYZabcdefghijklmnopqrstuvwxyz123
SAT0GAMMA.ttf	ABCXYZabcdefghijklmnopqrstuvwxyz123
SAT00CRB.ttf	A B C X Y Z a b c x y z 1 2 3
SAT0SANS.ttf	ABCXYZabcdefghijklmnopqrstuvwxyz123
SAT0SERIF.ttf	ABCXYZabcdefghijklmnopqrstuvwxyz123
SAT0SYM.ttf	f/... √∞-HΘIηθι678
SAT0VICA.ttf	ABCXYZabcdefghijklmnopqrstuvwxyz123
SAT0WING.ttf	☺☻☼☽☾☿♁♂♃♄♅♆♇♈♉♊♋♌♍♎♏♐♑♒♓♔♕♖♗♘♙♚♛♜♝♞♟♠♡♢♣♤♥♦♧♨♩♪♫♬♭♮♯♰♱♲♳♴♵♶♷♸♹♺♻♼♽♾♿



## Usable Barcodes

Code Type	S84NX	S86NX
Barcodes	<ul style="list-style-type: none"> <li>• UPC-A/UPC-E</li> <li>• JAN/EAN</li> <li>• CODE39, CODE93, CODE128</li> <li>• GS1-128(UCC/EAN128)</li> <li>• CODABAR(NW-7)</li> <li>• ITF</li> <li>• Industrial 2 of 5</li> <li>• Matrix 2 of 5</li> <li>• MSI</li> <li>• POSTNET</li> <li>• UPC add-on code</li> <li>• BOOKLAND</li> <li>• USPS code</li> <li>• GS1 DataBar Omnidirectional</li> <li>• GS1 DataBar Truncated</li> <li>• GS1 DataBar Stacked</li> <li>• GS1 DataBar Stacked Omnidirectional</li> <li>• GS1 DataBar Limited</li> <li>• GS1 DataBar Expanded</li> <li>• GS1 DataBar Expanded Stacked</li> </ul>	
2D Codes	<ul style="list-style-type: none"> <li>• QR Code</li> <li>• Micro QR Code</li> <li>• PDF417</li> <li>• Micro PDF</li> <li>• Maxi Code</li> <li>• GS1 Data Matrix</li> <li>• Data Matrix (ECC200)</li> <li>• Aztec Code</li> <li>• GS1QR Code</li> </ul>	
Composite Symbols	<ul style="list-style-type: none"> <li>• EAN-13 Composite (CC-A/CC-B)</li> <li>• EAN-8 Composite (CC-A/CC-B)</li> <li>• UPC-A Composite (CC-A/CC-B)</li> <li>• UPC-E Composite (CC-A/CC-B)</li> <li>• GS1 DataBar Composite (CC-A/CC-B)</li> </ul>	

Code Type	S84NX	S86NX
	<ul style="list-style-type: none"><li>• GS1 DataBar Truncated Composite (CC-A/CC-B)</li><li>• GS1 DataBar Stacked Composite (CC-A/CC-B)</li><li>• GS1 DataBar Expanded Stacked Composite (CC-A/CC-B)</li><li>• GS1 DataBar Expanded Composite (CC-A/CC-B)</li><li>• GS1 DataBar Stacked Omnidirectional Composite (CC-A/CC-B)</li><li>• GS1 DataBar Limited Composite (CC-A/CC-B)</li><li>• GS1-128 Composite (CC-A/CC-B/CC-C)</li></ul>	



- Specifications are subject to change without notice.
-

---

# Support and Warranty

---

## SOS (SATO Online Services) (SOS users only)

---

The SOS (SATO Online Services) is a remote maintenance service that monitors your product status for 24 hours and supports its stable operation. To use this service, create an SOS account and add your product.



For details on the SOS, refer to the SOS Portal Site.

 <https://www.sato-sos.com/en/>

## Warranty for Consumables within the Product Warranty Period

---

For information on the warranty period for print heads and platen rollers refer to the SATO Global Warranty Program.

 <https://www.sato-global.com/warranty/>

